



**ALIMCO**

**Artificial Limbs Manufacturing  
Corporation of India**  
(A GOVERNMENT OF INDIA UNDERTAKING)  
**G.T. ROAD, KANPUR-U.P.**  
**209217**

**TENDER NO. -PT/OT/05/AY**  
**DATE – 26/03/2021**

**TENDER DOCUMENTS**

**FOR**

**“CNC Laser Tube Cutting Machine with full safety enclosure Class-I”**  
**(On Turnkey Basis)**

Dear Sir,

1. Online tenders are invited for the supply, installation & Commissioning of “**CNC Laser Tube Cutting Machine with full safety enclosure Class-I**” (On Turnkey Basis) to the following destination conforming strictly to ALIMCO Specifications enclosed at Annexure-A, against Purchase Orders to be placed on the successful Tenderer within specified period as per Purchase Order. The specific conditions of supply are enclosed at Annexure-D. **Manual bids shall not be accepted.**

Sl. No.	CNC Laser Tube Cutting Machine with full safety enclosure Class-I (On Turnkey Basis) Delivery locations	Quantity
1	Artificial Limbs Manufacturing Corporation of India (ALIMCO) G.T. ROAD, Kanpur-209217 (U.P.)	Qty-03set
2	ALIMCO Auxiliary Production Center (AAPC) Plot No. 8, Peenya Plant Station Near Jalasaudha, PO-Jalahalli BANGALORE-560013	Qty-01set
3	ALIMCO Auxiliary Production Center (AAPC) S-3/66 Mancheswar Industrial Area, BHUBANESWAR-751010	Qty-01set
4	ALIMCO Auxiliary Production Center(AAPC) Plot No,40, 106 &107 Ricchai Industrial Area, Maharajpur, JABALPUR-482010	Qty-01set
5	ALIMCO Auxiliary Production Center,(AAPC) Plot No ,A-1,A-2,A-3 Industrial Focal Point, CHANALON, Mohali-140 103 PUNJAB	Qty-01set
6	ALIMCO Auxiliary Production Center(AAPC) Plot No. 16/2, Post – Manpura, Dewas Road, UJJAIN (M.P.) – 456 010	Qty-01set

2. The specification of “**CNC Laser Tube Cutting Machine with full safety enclosure Class-I**” (On Turnkey Basis) and a tentative quantity likely to be covered by Purchase Order is indicated in the **ANNEXURE- ‘A’**. The machine/item/equipment would be required to be supplied as per the delivery schedule specified in our Purchase Order or as indicated in the tender.

Sr. No.	Description	Qty.	Estimated Cost (in Rs.)
1.	<b>CNC Laser Tube Cutting Machine with full safety enclosure Class-I</b>	<b>08 Set</b>	<b>26.00 Crore</b>

3. Tender documents may be downloaded from ALIMCO website [www.alimco.in](http://www.alimco.in)(for reference only) and CPPP website <https://eprocure.gov.in/eprocure/app> as per the schedule as given in **CRITICAL DATE SHEET** as under.

CRITICAL DATE SHEET

Published Date & Time	27.03.2021 (10:00 HRS)
Bid Document Download Start Date & Time	27.03.2021 (10:00 HRS)
Pre bid Query start Date & Time	28.03.2021 (10:00 HRS)
Request for attending Pre-Bid meeting latest by	08.04.2021 (17:00 HRS)
Pre-Bid meeting Date & Time	09.04. 2021 (11.30 HRS)
Pre bid Query end Date & Time	12.04.2021 (17:00 HRS)
Bid Submission Start Date & Time	16.04.2021 (10:00 HRS)

Bid Submission End Date & Time	27.04.2021 (14:00 HRS)
Bid Opening Date & Time	28.04.2021 (15:30 HRS)

**Bids shall be submitted online only at CPPP website:** <https://eprocure.gov.in/eprocure/app>.

**Tenderer/Contractors are advised to follow the instructions provided in the 'Instructions to the Contractors/Tenderer for the e-submission of the bids online through the Central Public Procurement Portal for e Procurement at <https://eprocure.gov.in/eprocure/app>.**

Bid documents may be scanned with 100 dpi with black and white option which helps in reducing size of the scanned document.

**Part I ('TC' BID):**

The tenderers are requested to submit the scan copy of following details/documents in their 'TC'-Bid.

**Mandatory / Pre-Qualification Criteria):-**

- i) All tenderers are required to submit Rs. 600/- (including GST), towards cost of Tender documents, if down-loaded from the website of the Corporation/CPPP. (All SSI units/ MSE Vendors are exempted from Tender Cost on submission of valid Udyog Aadhaar memorandum (UAM)/Udyam Registration Certificate (UAC) against tender for the items/nature of business/ type of services specified there in the UAM/UAC. The cost of Tender documents for Rs. 600/- (Including GST) can be submitted **only through online payment gateway available at [www.alimco.in](http://www.alimco.in) and submit scan copy of the e-receipt of the same along with TC bid.**
- ii) The person signing the bid should be duly authorised representative of the firm/company whose signature should be verified and certificate of authority should be submitted. The poser or authorisation or any other document consisting of adequate proof of the ability of the signatory to bind the firm/company should be annexed to the bid.
- iii) Tender documents with proper seal and signature of authorised person on each page of the bid must be submitted.
- iv) The Complete specifications, Make/ Model/ Brand of Machine/ item/ equipment & its accessories offered on parameters specified as per Annexure-A, must be mentioned. The details with values for individual specifications/parameters desired must be indicated at Annexure 'B2 & B3' to this tender document.
- v) Copy of GST Registration Certificate, duly signed & stamped.
- vi) The tenderer should have an average annual turnover of not less than 30% of estimated value during the last 03 financial years i.e. FY: 2017-18, 2018-19 & 2019-20. In order to authenticate, **a certificate regarding average turnover during the above last three financial years from a qualified Chartered Accountant clearly mentioning the UDIN number in the certificate is required to be furnished along with TC-Bid.**
- vii) Copy of income tax return for the last three financial years, i.e. FY- 2017-18, 2018-19 & 2019-20, duly signed & stamped.
- viii) Only the OEM/authorised distributors/ authorised dealers are allowed to bid for machine/equipment/items/stores mentioned in the tender document. The Authorisation letter from Principal/OEM must be enclosed. **If in any case OEM and authorised Distributer/Dealer participate in the same tender, then all such offers shall be treated as single offer and the lowest price quoted among them will be considered.**
- ix) Vendor must have supplied at least five similar CNC Laser Tube Cutting machines in the last three years. Purchase order copies of five machines and their commissioning certificates to be submitted. Performance Certificates of 03 separate users, issued within 3 years from date of opening of this tender, shall be submitted.
- x) Undertaking stating that "The delivery, installation, commissioning and training of the plant (on turn-key Basis) must be completed within the stipulated period as indicated in the tender or specified at Annexure-A, from the date of placement of PO/work contract" **in the format enclosed at Appendix-1.**
- xi) The tenderer should submit an undertaking that his/her firm has not been debarred/blacklisted/terminated/banned to participate in the tender by any Govt. Institution, PSUs, and State Govt. or Central Govt. Deptt. **in the format enclosed at Appendix-2.**

- xii) The tenderer should submit an undertaking that his/her Offer is valid for acceptance for 120 days from the date of opening of TC Bids **in the format enclosed at Appendix-3.**
- xiii) Undertaking to the effect that all the tender terms & conditions are acceptable to the Tenderer **in the format enclosed at Appendix-4.**
- xiv) Undertaking to the effect that a Warranty Performance Bank Guarantee (PBG) of 3% of the order value, valid for warranty/defect liability period & claim submission date will be submitted after the commissioning of the Machine/item/equipment (on turn-key basis). The security deposit shall be released on receipt of 3% PBG valid for warranty period **in the format enclosed at Appendix-5.**
- xv) The tenderer should submit an undertaking that his/her firm shall provide Security Deposit @ 3% of the order value within 14 days of releasing PO **in the format enclosed at Appendix-6.**
- xvi) The tenderer should submit an undertaking that his/her firm shall provide the complete training regarding operation & maintenance of the Machine/item/equipment & its accessories (On turn-key Basis) & its accessories **in the format enclosed at Appendix-7.**
- xvii) The tenderer should submit an undertaking for unconditional acceptance to replace the supplies if rejected at the destination **in the format enclosed at Appendix-8.**
- xviii) Undertaking to be submitted by the tenderer that "They should undertake that they will execute comprehensive AMC including spares and labour for the period of 03 years after the expiry of warranty/defect liability period as per the requirement of ALIMCO and the AMC shall not exceed 6%, 7% & 8% of basic value of the machine/plant during 3<sup>rd</sup>, 4<sup>th</sup> & 5<sup>th</sup> year respectively from the date of successful installation & commissioning of the machine/plant/item/equipment" **in the format enclosed at Appendix-9 and 9/1**
- xix) Undertaking to be submitted by the tenderer that "payment terms mentioned at Para No-16 of this tender document (i.e. Terms of Payment) is acceptable" **in the format enclosed at Appendix-10.**
- xx) Tenderers are required to submit "**Tender Acceptance Letter**" in the format enclosed at **Appendix-11.**
- xxi) Tenderers are required to submit "**Undertaking**" regarding availment of GST and matching of Input credit in the format enclosed at **Appendix-12.**
- xxii) Tenderers are required to submit duly filled **Annexure 'B1, & B2,** enclosed herewith.
- xxiii) An affidavit to be sought from L1 party regarding,
  - a) The party has not been debarred/blacklisted/terminated/banned by any Govt. Institution, PSUs, and State Govt. or Central Govt. Deptt.
  - b) The party has not supplied the same Machine /System at a cost lower than the cost offered to ALIMCO to any government / semi-government /reputed private organisation in India
- xxiv) Latest Government of India guidelines as amended time to time on "Purchase Preference to Make in India" placed at **Appendix 13.**
  - a. Self certification that the items offered meets the local content requirement for 'Class-I local supplier/ 'Class-II local supplier, as the case may be as per **Clause 1 of Appendix 13 & 13/1.** – Tenderer to confirm
  - b. Certificate from the statutory auditor or cost auditor of the company (in case of companies) or from a practicing cost accountant or practicing chartered accountant (in respect of suppliers other than companies giving the percentage of local content as per **Clause 1 of Appendix 13 & 13/1** – Tenderer to furnish.
- xxv) Latest Government of India guidelines on "PUBLIC PROCUREMENT POLICY FOR GOODS PRODUCED AND SERVICES RENDERED BY MICRO AND SMALL ENTERPRISES (MSEs):" placed at **Appendix 14.**
- xxvi) Latest Government of India guidelines "Mandatory Conditions to be satisfied by any Tenderer from a country which shares a land border with India" placed at **Appendix 15.**

- a. Self attested copy of **Appendix 15** mandatory conditions to be satisfied by any Tenderer from a country which shares a land border with India. – Tenderer to confirm
- b. Certificate of compliance of clauses of **Appendix 15, clause A VII.** – Tenderer to confirm
- c. Certification as per last paragraph of **Appendix 15** mandatory conditions to be satisfied by any Tenderer from a country which shares a land border with India. – Tenderer to confirm

The **Appendix 15** must be signed and stamp and submitted/uploaded by Tenderer along with the bid. To be read in conjunction with Order (Public Procurement No. 2) F.No.6/18/2019-PDD dated 23rd July 2020 issued by Ministry of Finance, Department of Expenditure, Public Procurement Division. – Tenderer to Confirm

xxvii) In lieu of EMD, Bid Declaration in the format at **Appendix 16** to be given.

**(All these documents / details / conformation should necessarily be submitted specifically & in the same order.)**

**NOTE:**

- i) Price bids of only those tenderers, who are assessed as technically qualified by the Corporation shall be opened & only Such parties shall be communicated regarding date & time of Price Bid opening requesting them to attend the Tender opening, if interested.

**Part II ('P'BID):** shall consist of complete price details as under: -

P Bid offer shall be uploaded online. Rate should be quoted in Rupee per unit **as per format at Annexure-C (P-bid)**.Rate should be quoted for FREE DELIVERY at destination as indicated in Para 1 & should be without any price escalation clause. The following data shall be invariably furnished:-

- a) GSTIN No., HSN Code, GST in % & Rs.
- b) Packing & Forwarding charges, Installation charges, if any, in % & Rs.
- c) Freight charges in % & Rs. at FOR ALIMCO, (destination as indicated in para-1).
- d) Charges for installation and commissioning (if any) may please be clearly indicated. Alternatively, rates quoted shall be considered to be inclusive of installation & commissioning charges.

**THIS BREAKUP IS ESSENTIAL TO ENABLE PLACEMENT OF THE PURCHASE ORDERS AND PAYMENTS BY H.Q./AAPC's AS THE CASE MAY BE AND KEEPING IN VIEW APPLICABILITY OF GST BY THE GOVERNMENT w.e.f. 1<sup>st</sup> July 2017**

The L1 offer will be decided based on landed cost at ALIMCO (destination as indicated in para- 1 for CNC Laser Tube Cutting Machine (On Turnkey Basis) as per annexure A Delivery locations separately.

**NOTE:** ALIMCO GST Registration details are given below.

	H.Q, Kanpur	AAPC, Jabalpur	AAPC, Bangalore	AAPC, Bhubaneswar	AAPC Ujjain	AAPC Mohali
GST Regd. No.	09AABCA8899F1Z6	23AABCA8899F1ZG	29AABCA88999F1ZA	21AABC88999F1ZK	23AABCA8899F1ZG	03AABCA8899F1ZI

**Variation Clause:** - Any change (Increase / Decrease) in Govt. Duties / Levies / Taxes GST as amended made applicable by Govt. (State / Central) from time to time at the rate as will be applicable over & above the basic price/rate quoted by parties in their offer during the currency of Purchase Order/Contract shall be considered by the Corporation for amendment on party's request along with necessary documents in support of their claim/amendment.

4. **SITE INSPECTION** : The tenderers shall be deemed to have inspected and examined the site and its Surrounding and information available in connection therewith and to have satisfied himself, so far as is practicable, before submitting his tender, to the extent and nature of work and materials necessary for completion of works, availability of such materials, the means of access to the site and the accommodation that he may require and, in general, shall be deemed to have obtained all necessary information.
5. All the bids so received against the tender shall be scrutinized and assessed for the Machine/ equipment/ item suitability offered by you. Offers of only those tenderers whose bids are found

conforming to laid-down specifications and qualifying our requirements shall be considered. Quotes with any variation in the specifications affecting functions of the Machine/ equipment/ item as specified are liable for outright rejection. Tenderers are therefore requested not to quote for nonconforming specifications Machine/ Equipment's as an alternative one or two otherwise, for which tenders are liable for rejection. Each value in Part II (P-Bid) as specified is to be mentioned in tenders and words "as specified" or "same" shall not be considered valid at all.

6. No change in specifications by tenderers shall be permissible after submission of Technical Bids.

7. **EARNEST MONEY DEPOSIT & SECURITY DEPOSIT**

No earnest money (EMD) needs to be paid, In lieu of EMD, Bid Declaration in the format at **Appendix 16** to be given.

Subsequent to placement of Order / Contract, the successful tenderer will be required to deposit a sum equal to 3% of the Order/ Contract value subject to a maximum of Rs. 100.00 lakhs, within 14 days from the date of purchase order as **Security Deposit (SD)** in the form of 'Demand Draft' or 'Pay Order' or 'Bankers Cheque 'or 'Irrevocable Bank Guarantee' from any of Nationalized Bank/**Scheduled commercial Bank** in the prescribed format enclosed at **Annexure-E'** only in favour of **ALIMCO** payable at **Kanpur** for due discharge of the Purchase Order released on the basis of this tender. This will be retained till the expiry of warranty Period for the Item/ stores/ machine/ material supplied. No interest will be payable on the Security Deposit.

The Security deposit may be refunded/returned on submission of irrevocable, unconditional & acceptable Bank guarantee as performance guarantee of 3% of purchase Order/Contract value by the party to cover its obligations to offer free of cost replacement under the warranty period from any nationalized bank/ **Scheduled commercial Bank**.

Security deposit shall be furnished within the time limit provided for in the Contract. Non submission of Security deposit within the time specified for the purpose shall amount to the breach of essential conditions of the Contract and shall render the Contract liable to cancellation & the contractor shall be liable for all consequence thereof or caused there by.

After Satisfactory installation, commissioning & Training of the Machine/ item/ equipment and on receipt of Warranty Performance Bank Guarantee equal to 3% of the PO/work contract Value, valid for the warranty / defect liability period, the Security deposit amount (including of EMD) shall be released by ALIMCO.

The Corporation reserves the right to forfeit the security money deposit in case the supplier fails to make good losses on supplies, unable to replace supplies found unacceptable as well as losses on account of exceptional delays in supplies

8. **Submission of Tender**

**The tender shall be submitted online in two part, viz., technical bid and price bid**

**Technical Bid (TC Bid)**

The following documents are to be furnished by the tenderer along with **Technical Bid** as per the tender document

- 1) Scanned copy of e receipt against tender document cost / Exemption Certificate.
- 2) Scanned copy of all relevant documents as per Tender.

**Please note that no indication of the rates/amounts be made in any of the documents submitted with the TC-BID**

**PRICE BID (P Bid)**

(a) Schedule of price bid in the form of Annexure-C1 to C6.

9. **Pre-Bid Meeting (Physical/Virtual)**

- a) The tenderer may submit their queries on the tender document if any by email on the email id: [sm\\_pt@alimco.in](mailto:sm_pt@alimco.in) or [dgm\\_spc@alimco.in](mailto:dgm_spc@alimco.in). Only the queries submitted by the tenderers, who have either purchased or deposited the cost of tender documents after downloading the tender document from ALIMCO/ CPP website, would be discussed in pre-bid meeting. The pre-bid meeting with all the prospective bidder would be held on 08.04.2021 (11.30 hrs) through any video conferencing platform. The request for attending the online pre-bid meeting, along the email id's of participants, must be sent to email id: [sm\\_pt@alimco.in](mailto:sm_pt@alimco.in) or [dgm\\_spc@alimco.in](mailto:dgm_spc@alimco.in) latest by 07.04.2021 of 17:00 Hrs by prospective bidders, for sharing of online video conference invitation link.

- b) During the course of Virtual Pre-Bid Conference, the Tenderer will be free to seek clarifications and make suggestions for consideration of the Authority. The Authority shall endeavor to provide clarifications and such further information as it may, in its sole discretion, consider appropriate for facilitating a fair, transparent and competitive Selection process.
- c) Clarifications will be uploaded on ALIMCO website as per the schedule date fixed for submission. Any modification to tender document, which may become necessary as a result of pre bid meeting, shall be made through issuance of an Amendment/Corrigendum.

#### 10. OPENING & EVALUATION OF TENDER:

- a) The tenders shall be opened online at <https://eprocure.gov.in/eprocure/app> at 15.30 hours on due date in presence of representatives of tenderers who may like to be present. Tenderer can view live bid opening at their remote end also. Bids will be opened as per date/time as mentioned in the Tender Critical Date Sheet. After online opening of Technical-Bid the results of their qualification as well Price-Bid opening will be intimated latter.

Only the 'TC-Bid' (Part I) of the tender will be opened online on date as stipulated in para 3 CRITICAL DATE SHEET above by the Tender Opening Committee of ALIMCO in the presence of representatives of tenderers who may like to be present. **Tenders received late will not be considered. If the due date happens to be a holiday the same stands extended to the date of next working day with time remaining the same. However, the Corporation has the right to alter the date & time of Tender closing & opening. The same shall be notified only on the website of the Corporation.**The procedure will be as follows:

- b) Subsequent to opening of 'TC-BID' of all tenderers correspondence / discussion with regard to the conditions and other technical aspects may be held by the Technical Committee or by Officer(s) nominated by ALIMCO, if needed
- c) In case any tenderer submit only 'TC-BID' his tender shall not be considered and shall be treated as incomplete tender. Similarly, if any tenderer submit only 'P-BID', the same shall also be not considered.
- d) The technical bids will be evaluated to shortlist the eligible Tenderers. The technical bids of only the eligible Tenderers shall be considered for further processing (technical evaluation). Preliminary scrutiny of the proposal will be made to determine whether they are complete, required processing tender fee have been furnished whether the documents have been properly signed, and whether the bids are generally in order. Proposals not conforming to such preliminary requirements will be prima facie rejected.
- e) The ALIMCO has a right to seek clarification/ documents from the tenderer relating to TC-Bid of tenderers if such information is essential for evaluation of tender.
- f) Tenderer whose technical bid is found to be acceptable and meeting the Mandatory/Pre-qualification criteria as specified in this tender will only be informed about the date and time of the opening of the commercial bid (P-Bid).
- g) ALIMCO will open commercial bids of only the technically short listed bids, in the presence of the Tenderer or their authorised representative who choose to attend the bid opening, at the time and date to be informed later.
- h) Commercial bids of only those Tenderers will be opened who are found to be technically qualified & acceptable and the work shall be awarded to the commercially lowest Tenderer. The comparative statement of quotations (CSQ) of the P-bid will be prepared on FOR ALIMCO(as per defined destination in Para 1) and evaluated on the basis of complete price FOR ALIMCO (as per defined destination in Para 1) of the Machine/item/equipment including basic price, packing & forwarding, freight, taxes, installation & commissioning charges, etc.

#### 11. REJECTION OF TENDER:

- a) Tenders received without cost of tender document are liable to be rejected as also indicated at Para 3(i)
- b) Conditional and unsigned tenders, tenders containing absurd or unworkable rates and amounts, tenders which are incomplete or otherwise considered defective and tenders not in accordance with the tender conditions, drawings/specifications etc. are liable to be rejected.
- c) Canvassing in any form in connection with the tender is strictly prohibited and the tenders submitted by the party who resort to canvassing are liable to be rejected.

- d) The acceptance of tender will rest with ALIMCO which does not bind itself to accept the lowest tender or any tender and reserves full rights for the rejection of any or all tenders without assigning any reasons whatsoever.

**12. VALIDITY OF TENDER:**

- a) The tenders shall remain open for acceptance for a minimum period validity of 120 days from, the date of opening of tenders or till such period up to which the extension of validity is agreed to mutually. This may please be stipulated clearly in the Quotation.
- b) If notified within this period that the tender has been accepted, the tenderer shall be bound by the terms of the offer along with the terms that have been agreed mutually.
- c) All the tenders without PROPER SPECIFICATION / MAKE / BRAND / BROCHURE /CATALOUGE/ LEAFLET & TEST CERTIFICATES wherever required, are liable to be rejected. It shall be in the interest of the tenderer that complete offer is made for our consideration. It will be in the interest of the tenderer to submit details/values against each individual parameters mentioned at Annexure 'B2' and sample wherever possible along with the offer.
- d) In case the tenderer happens to be dealer/distributor for any reputed brand the validity certificate to this effect duly certified from the principal should invariably be provided.

**13. QUANTITY DISCOUNT:**

In order to submit the most competitive offer, the Tenderer may indicate the quantity discounts as applicable on the price. However, the buyer reserves the right to accept the quantity discounts for lower quantities as well. The quantities indicated in the Annexure 'A' are liable to revision either upwards or downwards.

**14. DELIVERY:**

- a) The delivery, installation, commissioning and training of the Machine/item/equipment/system and its accessories must be completed within the stipulated period specified at Annexure-A, from the date of placement/acceptance of PO/ work contract.
- b) The delivery of the Machine/item/ equipment/ system shall be made strictly as per delivery schedule as stipulated in our Purchase Order/Work Contract or modified time to time by ALIMCO. In case of Failure to supply, install & commission/execution of work within the stipulated period will make the tenderers liable to an unconditional penalty. The penalty/Liquidated damages shall be levied at the rate of point five percent (i.e. 1/2 % or 0.5%) per week (or fraction of a week) subject to the maximum of 10% of the purchase order / work contract value.

**15. INSPECTION:**

- a) Inspection will be carried out at the Destination (refer Para 1) and unacceptable/ rejected Item will be returned to the supplier through bank at the supplier's risk and cost by road, only after receipt and acceptance of replacement supplies provided by the suppliers free of cost. Alternatively, all the tenderer will have to furnish their Banker's Name, Address including Code No. along with a declaration/undertaking to guarantee collection of the returned supplies documents negotiated through their bank within 07 days of its presentation.
- b) In case of local supplier, rejected Item shall be lifted from our stores within 15 days of our rejection advice after refunding the payment, if already made to them before collecting the supply. In case of failure to lift the rejected Item, we may dispose-off the rejected Item as deemed fit and no claim whatsoever shall be entertained in this respect and the tenderer shall be liable to pay amount paid by ALIMCO, if any.

**16. TERMS OF PAYMENT:**

ALIMCO is a Schedule 'C' Mini Ratna Category II Central Public Sector Enterprises, registered under Section 8 (Not for Profit motive) of the Companies Act, 2013, (corresponding to Section 25 of the Companies Act, 1956). The terms of payment shall be as follows:

- a) 80% (excluding GST) payment shall be released within 30 days after receipt of the Machine/item/equipment and its accessories at destination as specified in Para 1 without any damage/short supplies and balance 20%(excluding GST) payment shall be released within 30 days



after Satisfactory installation & commissioning of the Machine/item/equipment and its accessories subject to receipt of performance Bank guarantee from a nationalized bank equal to 3% of the PO/work contract Value, valid for the warranty period & claim submission date within 3 month from the date of expiry of Bank Guaranty/warranty period.

- b) Any expenses towards transit insurance to be borne by the tenderer.
- c) In case of PDI at party's worksite, all the cost to be borne by ALIMCO. Going for PDI is at sole discretion of ALIMCO, tenderer to inform the tentative dates for PDI at their work.
- d) GST portion shall be paid on availment and matching of Input Credit.
- e) Supplier's Bank Charges/Draft making charges will have to be borne by the party only.
- f) The tenderer will be required to submit their RTGS details duly certified by the Bank along with a crossed/cancelled Cheque in support of the details, as all payments/refunds are preferably be made through RTGS.

**17. RIGHT OF ACCEPTANCE:**

ALIMCO reserves the right to reject any or all the tenders in part or full without assigning any reasons thereof. The Corporation also reserves the right to negotiate the rates and terms and conditions of supply with any or all the tenderers at its sole discretion as deemed fit without assigning any reasons thereof.

**ARBITRATION**

In case of any dispute, arising during the operation of the contract, efforts shall be made to resolve it by mutual discussions failing which the matter shall be referred to the Chairman & Managing Director of ALIMCO G.T.Road, Kanpur-209217 or his nominee whose decision shall be final and binding on both the parties. Arbitration proceedings shall be held at Kanpur as per provisions of the Arbitration & Conciliation Act 1996 & as amended from time to time and the Kanpur City Court shall have the jurisdiction in the matter.

Thanking you,

Yours faithfully,  
for Artificial Limbs Mfg. Corporation of India

Dy. General Manager (SP&C)

**Encl:** As Above

## **ANNEXURE – A**

### **“CNC Laser Tube Cutting Machine with full safety enclosure Class-I”** **(On Turnkey Basis)**

**Code No.**

**Total Qty. – 08 sets**

<b>1</b>	Artificial Limbs Manufacturing Corporation of India (ALIMCO) G.T. ROAD, Kanpur-209217 (U.P.)	<b>Qty-03set</b>
<b>2</b>	ALIMCO Auxiliary Production Center (AAPC) Plot No. 8, Peenya Plant Station Near Jalasaudha, PO-Jalahalli BANGALORE-560013	<b>Qty-01set</b>
<b>3</b>	ALIMCO Auxiliary Production Center (AAPC) S-3/66 Mancheswar Industrial Area, BHUBANESWAR-751010	<b>Qty-01set</b>
<b>4</b>	ALIMCO Auxiliary Production Center(AAPC) Plot No,40, 106 &107 Ricchai Industrial Area, Maharajpur, JABALPUR-482010	<b>Qty-01set</b>
<b>5</b>	ALIMCO Auxiliary Production Center,(AAPC) Plot No ,A-1,A-2,A-3 Industrial Focal Point, CHANALON, Mohali-140 103 PUNJAB	<b>Qty-01set</b>
<b>6</b>	ALIMCO Auxiliary Production Center(AAPC) Plot No. 16/2, Post – Manpura, Dewas Road, UJJAIN (M.P.) – 456 010	<b>Qty-01set</b>

**Scope:-**

1. Laser Tube Cutting System.

2. CNC System and Software.

**PURPOSE:-**

All types of Tube (material & thickness as mentioned) to be cut for ALIMCO products through this CNC Laser Tube Cutting Machine.

S. No.	Description of Requirement	Required
1	Cutting tube details	
1.1	Laser cutting of Round tubes	At-least from $\phi$ 15-38 mm
1.2	Laser cutting of rectangular tubes	At-least up to 65mmx38 mm
1.3	Loadable bar / tube length	At-least up to 6250 mm
1.4	Material: Iron (mild steel), SS, Al, Cu, Brass to be cut by laser	Confirm
1.5	Cutting thickness (MS Tube)	At-least up to 2.5 mm
1.6	Cutting thickness (SS Tube)	At-least up to 2 mm
1.7	Cutting thickness (Aluminum Tube)	At-least up to 2 mm
1.8	Capacity of loading cradle	Min. 1500 Kg
1.9	Laser tube cutting system, consisting of :	
1.9.1	Measurement and automatic bar loading system, tube guiding and supporting device	Confirm
1.9.2	Electrical cabinet	Confirm
1.9.3	Safety devices i.e. guard, Alarm system etc.	Confirm
1.9.4	Guide steady near cutting head with electronically synchronized chuck, CNC motorized axial positioning, including full stock clamping independent adjustment jaws.	Confirm
1.9.5	Integration of automatic loader for tubes (round, square, rectangle and flat oval tubes) including positioning / orientation system.	Confirm
1.9.6	Automatic worked piece discharge-support system for scrap pieces.	01 Set
1.9.7	Parts collecting table with conveyor and horizontal motorized chains covered with rubber.	01 Set
2	Controller:	
2.1	Siemens/Fanuc/Beck-Hoff/ABB/BR Automation/Mitsubishi	Vendor to specify
2.2	Laser safety window with full safety enclosure Class-1	Confirm
2.3	TFT color touch monitor	Min 19"
2.4	USB Port for program loading with source key	Confirm
2.5	Ethernet connectivity through network card	Confirm
3	Laser Source	
3.1	Fiber laser source with pulse generator, control panel and control	Confirm
3.2	Laser source. Specification of Laser Source to be specified.	Fiber laser
3.3	Fiber laser source nominal power	Minimum 2000 W
3.4	Fiber Laser Make	IPG/Trumpf/AMADA
3.5	Lens holder	01 Set
3.6	Chiller with closed circuit for laser source, Specify make of Chiller unit. Specify quality, quantity of water requirement, temperature of inlet cooling water. Chemical composition of additives and rust inhibitors if added to water, to be specified. All these items are in scope of Tenderer including demineralised water. Additives and rust inhibitors to be supplied for one year requirement are in scope of Tenderer.	Confirm & Specify
3.7	Filtered Fume extractor with high efficiency filter cartridges. Hourly air flow rate Min. 1500 m <sup>3</sup> /h. Details to be specified. Specify make of filter. Ducting from blower out let as per site condition to be quoted in rupees per meter length in the Price Bid. Self-cleaning Filter cartridge with compressed air pulsing shall be provided. Tenderer to explain the system. Spark Arrestor for protection of the filter chamber from sparks and coarse particles. The exhaust air must meet the Air Quality Index (AQI) in the working area as per government norms issued by Central Board for AQI quality "GOOD".	Confirm & Specify

3.8	Beam delivery system details	Confirm & Specify
3.9	Cut Accuracy	As per ISO 9013 or latest
3.10	Laser Beam Alignment Kit	Confirm
3.11	Cutting head should have automatic positional check and precise cutting head focus arrangement. Non-Contact Capacitive Height sensing device. Cutting Head should be of reputed OEM make.	Confirm
3.12	Cutting head should have protection against unintended crash with work piece.	Confirm
3.13	The cutting lens shall be cleaned without disassembly of the complete cutting head. Specify make of lens.	Confirm
3.14	Machine shall have automatic corner control mechanism such that it selects appropriate laser parameters while executing corner cutting/fine reduced edges.	Confirm
3.15	Auto-interruption of laser beam during abnormal functioning of machine system.	Confirm
3.16	International Safety Certifications, to which the machine complies, shall be furnished.	Confirm & Specify
<b>4</b>	<b>Basic Machine Features</b>	
4.1	The laser and electrical cabinet shall have safety enclosure and same should be air conditioned. This is in scope of Vendor.	Confirm
4.2	Rigid and Stress relieved Machine Frame with hardened guides.	Confirm
4.3	Vendor to specify make of Drive System and details of transmission system.	Confirm & Specify
4.4	Single cutting head with common lens mechanism. Specify make of cutting Head. The cutting head shall be able to cut bevels up to an angle of 45 degrees.	Confirm
4.5	Non-Contact Capacitive Height sensing device	Confirm
4.6	Programmable cutting gas pressure selection	Confirm
4.7	Automatic Tube referencing System	Confirm
4.8	Gravity Conveyor chute and slag Trolley for slag and smaller parts	Confirm
4.9	Programmable nozzle cleaning facility	Confirm
4.10	Automatic Hole Piercing System	Confirm
<b>5.</b>	CNC System, Control Panel, Hardware, Software & IT Systems. Make of CNC controller. Size of LCD color monitor to be specified. CNC system provided shall be capable of: a) Rotary Axis clockwise & anti-clockwise rotation b) Y-Axis forward & backward movement c) Z-Axis for up & down movement d) Bevel Axis 45°	Confirm & Specify
5.1	Offline programming system should have a CAD module to design and draw a workable piece. It should be able to import IGES/STEP/DXF file for program generation.	Confirm
5.2	Software should have library of bend cut management.	Confirm
5.3	CAM system for automatically applying the cutting parameters on every part geometry and decide the operating sequence, cutting strategy (auto nesting).	Confirm
5.4	Integrated parametric three-dimension software suited to design and draw tubes of any type and section and to automatic generate the single relevant components	Confirm
5.5	Post processor for loading of program to the machine	Confirm
5.6	Perpetual PC license of the software for operating and checking on PC. Make of Cutting Software.	Confirm/Specify
5.7	System configuration- As per software requirement; with	Confirm

	<p>following minimum requirements</p> <p>i) Compatible O.S. Genuine Windows 10 Professional 64 bit or above</p> <p>ii) Processor: Inteli7 or Xeon E3, 3.2Ghz or faster</p> <p>iii) Min. 1920*1080 resolution, monitor size- 23" (min.)</p> <p>iv) Storage: SSD with at least 1 TB</p> <p>v) Memory: 32 GB extendable up-to 64 GB</p> <p>vi) NVIDIA graphic card Min. 8 GB memory</p>	
5.8	Make of CNC System	Specify
5.9	3D graphical simulation of part program to check the correct location of the work and estimate the hourly productivity.	Confirm
	<b>GENERAL OPERATING CONDITION</b>	
<b>6</b>	Electrical should be designed for	
6.1	3 Phases 415V ( $\pm 10\%$ )	Confirm
6.2	Frequency 50 Hz ( $\pm 3\%$ )	Confirm
6.3	Total Electrical Power required (In KW)	Specify and Confirm
6.4	Protection level	IP54 or better
<b>7</b>	Complete electrical system with tropicalization for Indian condition +0°C to +50°C temp and RH 100%	Confirm
<b>8</b>	Service: The authorized Service Partners in India (Name & Address) must be certified by manufacturer and shown in the quotation	Confirm
<b>9</b>	Machine to have capability to handle voltage and current fluctuation and power backup required for minimum 15 mins. for CNC control system. UPS of 15 min. battery back and Isolation Transformer to be provided.	Confirm
10	Spares, Consumables & Accessories: (all following sets of items to be provided against each individual machine separately)	Confirm
a)	Limit switches (02 Sets)	Confirm
b)	CNC Panel Keys (02 Sets)	
c)	Fuses (05 Set of each type of fuse)	
d)	Protection Mirror lens (10 Nos.)	
e)	Cutting Lens (02 Nos)	
f)	Ceramic ring (04 Sets)	
g)	Cutting nozzles – Total 50 numbers. (Tenderer to specify quantity of different nozzle sizes)	
h)	Protective Eyewear for operators(10 numbers)	
i)	Protective Gloves for operations (20 Sets)	
j)	Lens cleaning paper, cloth, cleaning bud(5 Sets)	
k)	High purity Acetone (100ml)	
<b>11</b>	Supplier shall provide undertaking for availability of machine spares up to minimum 10 years from date of supply.	Confirm
<b>12</b>	Documentation: Following documents (3 sets of hard copy and 1 set of soft copy) along with delivery will be required	Confirm
12.1	Operating instruction	Confirm
12.2	Quality Test records	Confirm
12.3	Preventive maintenance instructions	Confirm
12.4	Lubrication chart & parameter list	Confirm
12.5	Lifting instruction mentioned in packing list.	Confirm
12.6	Detailed invoice and packing list of all items and all other accessories enclosed in respective boxes	Confirm
<b>13</b>	Training at site (for a team as decided)	
13.1	Operation and Programming	14 Days
13.2	Preventive maintenance training	10 Days
<b>14</b>	Prove-out:	
14.1	Vendor to perform complete trial run and prove out	Confirm
	Vendor has to prove-out cutting of items after successful installation and commissioning at site for a period of 04 days	

14.2	having eight-hour shifts. Raw material shall be provided by Company. Drawings Enclosed Successful vendor to prepare AutoCAD drawing of the components to be proved out	Confirm
15	Delivery Period (including, Installation & Commissioning and training)	6 months
16	Packaging and Transportation is in the scope of vendor.	Confirm
17	Installation and Commissioning should be done within 21 days on receipt of machine at Kanpur by the vendor. All necessary things to maintain precision & accuracy shall be done by vendor at the time of handover the machine.	Confirm
18	Tenderers shall have supplied at least 5 similar capacity Laser Tube cutting machine in Govt. Sector/ Private Sector in the last three years. (PO copies and Commission /Completion Certificates/ proof of the same to be furnished). Performance Certificate of 03 users issued within last 03 years.	Confirm
19	Warranty	2 Years

#### **DELIVERY PERIOD INCLUDING INSTALLATION & COMMISSIONING AND TRAINING :**

The delivery period including installation & commissioning and training at site of all of the machines at the destination mentioned in Para 1 on page no. 02 of the tender documents will be 06 months from the date of placement of Purchase Order/work contract.

#### **WARRANTY:**

The entire machine inclusive of all system/accessories should be covered under warranty for a period of 24 months (min.) from the date of successful commissioning (Warranty shall specifically cover laser source).

#### **Note:**

1. The loading/unloading of machine & other components of supply and their handling at destination site is in the scope of vendor.
2. Supply to be done on Turnkey Basis. Company shall provide electrical supply point near to the place of installation.
3. Machine shall be supplied with 3 sets of comprehensive operation and maintenance manual, Spare part catalogue, electrical circuits, manuals of bought out imported and indigenously purchased items in hard copy and soft copy.
4. Breakdown calls to be attended within 72 hrs. Physically or through tele-diagnostic.
5. Machine foundation details and drawings with specifications to be provided by the tenderer.
6. Total power consumption (in kW) to be provided by the tenderer.
7. The Bus-bar trunking (BBT) for electricity has been provided at 8.5 meter height. Sufficient suitable cable, cable tray, Circuit breaker, panel fittings to connect the machine from power source is in vendor's scope. Suitable power backup for failsafe operation of machine in the event of Power failure is in vendor's scope.
8. Compressed air pipeline is available in the work center (air pressure will be available approx. 5.5 to 6 bar). All necessary fittings, air dryer, air booster as per machine requirements, is in vendor's scope. Tenderers to specify average consumption of compressed air.
9. Vendor to arrange any foundation work/grouting of anti-vibration pads or foundation bolts for the installation of machine.
10. Consumables required for smooth functioning of machine for a period of one year is in scope of vendor.
11. Vendor shall provide cutting gas bank both for cutting MS tubes and SS/Al, tubes. Vendor to submit quality of cutting gas, per day consumption and nearby source of cutting gas. A bank of 15 cylinders of cutting gas for cutting MS and 5 cylinders of cutting gas for SS/Al shall be provided with pipeline, pressure Regulators, non-return valves, etc.
12. Spare filled cylinders 15 numbers for cutting MS and 5 cylinders for cutting SS/Al to be provided by vendor.
13. Proper earthing of plant/machinery is in vendor scope. If separate earthing is required for machine/plant than earthing pit is in vendor scope.
14. Vendor to specify requirement of demineralised water. One year requirement of demineralised

water is in scope of Vendor.

15. Voltage Stabilizer and Ultra isolation Transformer are in scope of Vendor.
16. Vendor to specify minimum inventory of critical spares to be maintained for 02 years (Manufactures recommended list of spares).
17. Any related civil work is in the scope of vendor.
18. Vendor should undertake that they will execute comprehensive AMC including spares and labour for the period of 03 years after the expiry of warranty/defect liability period as per the requirement of ALIMCO and the AMC shall not exceed 6%, 7% & 8% of basic value of the machine/plant during 3<sup>rd</sup>, 4<sup>th</sup>& 5<sup>th</sup> year respectively from the date of successful installation & commissioning of the machine/plant/item/equipment.
19. Vendor shall take full responsibility for the adequate stability and safety of all site operations and installation & commissioning as per the latest safety manuals published by Indian Standards Institution Statutory rules regulations and provisions of order conditions etc. and in case of default, Vendor shall solely be responsible and indemnify the corporation for any loss or damage caused to the ALIMCO for any violation of concerned laws.

(On Letter Head of the Tenderer)

**APPENDIX-1**

**UNDERTAKING**

We hereby undertake that The delivery, installation and commissioning of the Machine/item/equipment& its accessories must be completed within the stipulated period as indicated in the tender or specified at Annexure-A from the date of placement of PO/work contract (within 05 months from date of placement of order).

Dated:

Authorised Signatory :

Name :-

Designation :-

Seal :-



(On Letter Head of the Tenderer)

**APPENDIX -2**

**UNDERTAKING**

We hereby undertake that our Firm has not been debarred/blacklisted/terminated/banned to participate in the Tender by any Govt. Institution, PSU, State Govt. or Central Govt. Deptt.

Dated:

Authorised Signatory :

Name :-

Designation :-

Seal :-

(On Letter Head of the Tenderer)

**APPENDIX -3**

**UNDERTAKING**

We hereby undertake that our Offer is valid for acceptance for 120 days from the date of opening of Techno-Commercial Bid (TC-Bid).

Dated:

Authorised Signatory :

Name :-

Designation :-

Seal :-

(On Letter Head of the Tenderer)

**APPENDIX -4**

**UNDERTAKING**

We hereby undertake that all the tender terms & conditions are acceptable to us.

Dated:

Authorised Signatory :

Name :-

Designation :-

Seal :-

(On Letter Head of the Tenderer)

**APPENDIX -5**

**UNDERTAKING**

We hereby undertake that a Performance Bank Guarantee (PBG) of 3% of the order value, valid for warranty period & claim submission date within 3 month from the date of expiry of Bank Guaranty/warranty period, will be submitted after the commissioning of the Machine/item/equipment& its accessories.

Dated:

Authorised Signatory :

Name :-

Designation :-

Seal :-

(On Letter Head of the Tenderer)

**APPENDIX -6**

**UNDERTAKING**

We hereby undertake that our firm shall submit the security deposit as per tender terms within 14 days of releasing PO/Work Order of the Machine/ item/ equipment/ system (on turn-key basis).

Dated:

Authorised Signatory :

Name :-

Designation :-

Seal :-

(On Letter Head of the Tenderer)

**APPENDIX -7**

**UNDERTAKING**

We hereby undertake that our firm shall provide the complete training regarding operation & maintenance of the Machine/item/equipment & its accessories.

Dated:

Authorised Signatory :

Name :-

Designation :-

Seal :-

(On Letter Head of the Tenderer)

**APPENDIX -8**

**UNDERTAKING**

We hereby undertake that we will unconditionally accept to replace the supplies if rejected at the destination.

Dated:

Authorised Signatory :

Name :-

Designation :-

Seal :-

(On Letter Head of the Tenderer)

**APPENDIX -9**

**UNDERTAKING**

We hereby undertake that we will execute Comprehensive AMC for the period of 03 years after the expiry of warranty period as per the requirement of ALIMCO and the AMC shall not exceed 5%, 6% &7% of basic value of the machine during 3<sup>rd</sup>, 4<sup>th</sup>& 5<sup>th</sup> year respectively from the date of successful installation & commissioning of the machine/item/equipment.

Dated:

Authorised Signatory :

Name :-

Designation :-

Seal :-



**COMPREHENSIVE ANNUAL MAINTENANCE CONTRACT (AMC)**

**1. Responsibilities of the Firm**

Preventive maintenance, including calibration, shall be conducted through mutual agreement with the nominated ALIMCO site official. The preventive maintenance regime offered must be aimed at achieving minimum 98% uptime of the System including the System down time for preventive maintenance schedules.

2. The tenderer shall ensure that in case a failure is reported, the system is restored to the complete working status within 48 hours. This period of upto 48 hours after the failure report shall be treated as grace period, which will not count towards System down time for up to one failure per quarter and a maximum of 4 failures per annum. In case the number of failures exceeds one during any quarter or four during any year of AMC, grace period of only 24 hours will be permissible for such additional failures.

3. The successful Tenderer should submit a list of authorised persons for carrying out the AMC of the System. The Tenderer shall be solely responsible for the safety of all the men and equipment of the Tenderer. The authorised person shall observe all safety and security rules prevailing at the place of work. ALIMCO shall not be responsible for any mishap resulting out of non-observance of prevailing safety and security rules.

4. All costs involved in hiring, deployment etc. for the Tenderer’s personnel should be borne by the Tenderer.

5. The Tenderer should ensure that there is no damage to the ALIMCO property/material.

**6. Payments**

Normally quarterly payment under Comprehensive AMC will be made to the tenderer within 30 days from the end of the quarter subject to submission of following documents by the tenderer to the paying authority assigned by the consignee:

- i. Detailed quarterly bill by the Tenderer and accepted by the consignee
- ii. Consignee’s Certificate for Quarterly Work Done Under AMC
- iii. Details of system malfunction calls logged.
- iv. Certification from the nominated official of ALIMCO for the functioning of sites in his jurisdiction
- v. Attested photocopy of AMC BG

7. Any spare part or material necessary to restore the Machine/ item/ equipment/ system to proper working order will be arranged by the tenderer as a part of AMC.

8. **Penalty Clause:** Penalty shall be levied on the Tenderer for maintaining the System uptime below the limit of 98% (on quarterly basis), after discounting for grace period. Penalty shall be calculated as % age of quarterly payment and will be deducted from the respective quarterly payments. Penalty calculation will be done over quarterly payment period.

<b>S.No.</b>	<b>Availability Slab</b>	<b>Applicable Penalty</b>
1.	98% to 90%	0.5% for every 1 % ( or part thereof) reduction in availability below 98%.
2.	Below 90%	1% for every 1% (or part thereof) reduction in availability below 90%.

9. In case the tender fails to provide AMC services successfully, the AMC BG will be forfeited. This will be in addition to penalty as per clause above. System up time of less than 60% for two consecutive quarters will constitute complete failure of Tenderer to provide AMC services successfully.
10. Necessary records for AMC will be maintained online by the Tenderer or reference of both the parties.
11. In the event of failure of Tenderer to provide AMC services as per the AMC agreement, the AMC contract shall be terminated in following way:

Notice in writing by Client, ALIMCO giving 3 months' clear notice period. Dues, if any, will be settled in accordance with the conditions of the agreement.

Dated:

Authorised Signatory :

Name :-

Designation :-

Seal :-

(On Letter Head of the Tenderer)

**APPENDIX -10**

**UNDERTAKING**

We hereby undertake that payment terms mentioned at Para No-16 of this tender document (i.e. Terms of Payment) is acceptable to us.

Dated:

Authorised Signatory :

Name :-

Designation :-

Seal :-

**TENDER ACCEPTANCE LETTER**  
(To be given on Company Letter Head)

Date:

To,

\_\_\_\_\_  
\_\_\_\_\_  
\_\_\_\_\_  
\_\_\_\_\_

Sub: Acceptance of Terms & Conditions of Tender.

Tender Reference No: \_\_\_\_\_

Name of Tender / Work: \_\_\_\_\_

Dear Sir,

1. I / We have downloaded / obtained the tender document(s) for the above mentioned 'Tender/Work' from the web site(s) namely:

\_\_\_\_\_  
\_\_\_\_\_

as per your advertisement, given in the above mentioned website(s).

2. I / We hereby certify that I / we have read the entire terms and conditions of the tender documents from Page No. \_\_\_\_\_ to \_\_\_\_\_ (including all documents like annexure(s), schedule(s), etc .), which form part of the contract agreement and I / we shall abide hereby by the terms / conditions / clauses contained therein.

3. The corrigendum(s) issued from time to time by your department/ organisation to have also been taken into consideration, while submitting this acceptance letter.

4. I / We hereby unconditionally accept the tender conditions of above mentioned tender document(s) / corrigendum(s) in its totality / entirety.

5. I / We do hereby declare that our Firm has not been blacklisted/ debarred/ terminated/ banned by any Govt. Department/Public sector undertaking.

6. I / We certify that all information furnished by our Firm is true & correct and in the event that the information is found to be incorrect/untrue or found violated, then your department/ organisation shall without giving any notice or reason therefore or summarily reject the bid or terminate the contract, without prejudice to any other rights or remedy including the forfeiture of the full said earnest money deposit absolutely.

Yours Faithfully,  
(Signature of the Tenderer, with Official Seal)

**UNDERTAKING**

We hereby confirm that payment of basic value within 30 days after supply & acceptance/approval of Machine/item/equipment& its accessories or Submission of bill, whichever is later, is acceptable to us. However, the GST portion shall be claimed only after submission of GST Return and Input credit appearing in corporation's GST portal, filed online by the tenderer clearly (duly highlighted) showing invoice/ bill number and amount to ALIMCO so as to enable the Corporation to avail GST input credit after matching of the GST return and Invoice submitted in the Corporation. No claim against the Corporation shall be made for non-matching of GST and the amount shall be credited back by us.

Dated:

Authorised Signatory :

Name :-

Designation :-

Seal :-

## PURCHASE PREFERENCE TO MAKE IN INDIA

**1. Purchase Preference to Make in India**

In order to give effect to the policy of Government of India to encourage 'Make in India', price preference shall be accorded to Local Supplier/Tenderer in accordance with Order No.P-45021/2/2017-PP (BE-II) dated 04.06.2020 & 16.09.2020 on Public Procurement (Preference to Make in India) Order 2017 as per latest amendment of the Department of Industrial Policy and Promotion, Ministry of Commerce and Industry. ALIMCO Ltd being a CPSU adopted the guidelines given in the above-mentioned Order dated 04.06.2020 & 16.09.2020 and the following shall be applicable in this tender:

**1.1. Definitions:**

**'Local Content'** means the amount of value added in India which shall be the total value of the item procured (excluding net domestic indirect taxes) minus the value of imported content in the item (including all custom duties) as a proportion of the total value, in percent.

**'Class-I local supplier'** means a supplier or service provider, whose goods, services or works offered for procurement, has local content equal to or more than 50%, as defined under this clause.

**'Class-II local supplier'** means a supplier or service provider, whose goods, services or works offered for procurement, has local content more than 20% but less than 50%, as defined under this clause.

**'Non - local supplier'** means a supplier or service provider, whose goods, services or works offered for procurement, has local content less than or equal to 20%, as defined under this clause.

**'L1'** means the lowest tender or lowest bid or the lowest quotation received in a tender, bidding process or other procurement solicitation as adjusted in the evaluation process as per the tender or other procurement solicitation.

**'Margin of purchase preference'** means the maximum extent to which the price quoted by a "Class-I local supplier" may be above the L1 for the purpose of purchase preference.

**'Procuring entity'** means ALIMCO

**'Works'** means all works covered in the scope of work in this tender.

**1.2. Eligible Tenderer in this tender: Class-I local supplier****1.3. Purchase Preference**

(a) Deleted.

(b) In the procurement of goods or works which are not divisible in nature, and in procurement of services where bid is evaluated on price alone, the 'Class-I local supplier' shall get purchase preference over 'Class-II local supplier' as well as 'Non-local supplier', as per following procedure:

i) Among all qualified bids, the lowest bid will be termed as L1. If L1 is 'Class-I Local supplier', the contract will be awarded to L1.

ii) If L1 is not 'Class-I local supplier', the lowest Tenderer among the 'Class-I local supplier', will be invited to match the L1 price subject to Class-I local supplier's quoted price falling within the margin of purchase preference, and the contract shall be awarded to such 'Class-I local supplier' subject to matching the L1 price.

iii) In case such lowest eligible 'Class-I local supplier' fails to match the L1 price, the 'Class-I local supplier' with the next higher bid within the margin of purchase preference shall be invited to match the L1 price and so on and contract shall be awarded accordingly. In case none of the 'Class-I local supplier' within the margin of purchase preference matches the L1 price, the contract may be awarded to the L1 Tenderer.

(c) "Class-II local supplier" will not get purchase preference in any procurement, undertaken by procuring entity.

**1.4. Applicability of Purchase preference in this tender as per Para 3(b)**

- 1.5.** Type of this Tender/Work: Supply
- 1.6.** Margin of Purchase Preference: The margin of purchase preference shall be 20%.
- 1.7.** The minimum local content for this tender shall be 50% (Minimum Local content will apply on all items of price schedule excluding AMC cost.
- 1.8.** Verification of local content:
- a. The 'Class-I local supplier'/'Class-II local supplier' at the time of tender, bidding or solicitation shall be required to indicate percentage of local content and provide self-certification that the item offered meets the local content requirement for 'Class-I local supplier'/'Class-II local supplier', as the case may be. They shall also give details of the location(s) at which the local value addition is made.
  - b. In case of procurement for a value in excess of Rs. 10 crores, the 'Class-I local supplier'/'Class-II local supplier' shall be required to provide a certificate from the statutory auditor or cost auditor of the company (in case of companies) or from a practicing cost accountant or practicing chartered accountant (in respect of suppliers other than companies) giving the percentage of local content.

Dated:

Authorised Signatory :

Name :-

Designation :-

Seal :-

**UNDERTAKING**

**Percentage of local content certificate**

**To be certified by statutory auditor/cost-auditor of the company/practicing cost-accountant/practicing chartered accountant**

We.....(Name of the statutory auditor/cost-auditor of the company/practicing cost-accountant/practicing chartered accountant) having checked the books of account, related documents and information furnished for the purpose of local content minimum 50% in terms of quoted value (as per the tender clause no. 2- xxiv) of Tender No.....and explanation given by the..... (Name of the tenderer) having registered office at ..We hereby certify that the Local Content in terms of quoted value is..... Percent. This certificate has been issued on the basis of records/books.

Dated:

Authorised Signatory :

Name :-

Designation :-

Seal :-



**PUBLIC PROCUREMENT POLICY FOR GOODS PRODUCED AND SERVICES RENDERED BY MICRO AND SMALL ENTERPRISES (MSES):**

a) As per the extant Public Procurement Policy of the Government of India, Micro and Small Enterprises (MSEs) having current and valid registration for the tendered item with any of the below specified agencies are entitled for benefits and preferential treatments specified in Para d below. MSEs who are interested in availing themselves of these benefits must upload with their offer, the proof of their being MSE registered with any of the agencies mentioned in the notification of the Ministry of MSME (Udyog Aadhar Memorandum)/Udyam Registration Certificate as indicated below:

- i) District Industries Centers
- ii) Khadi and Village Industries Commission
- iii) Khadi and Village Industries Board
- iv) Coir Board
- v) National Small Industries Corporation
- vi) Directorate of Handicraft and Handloom
- vii) Any other body registered with MSME

Note: Trading enterprises are not covered under the definition of Micro and Small Enterprises.

b) The MSEs must also indicate the terminal date of validity of their registration.

c) Non compliance of requirements of para (a) and (b) above, such offers will not be liable for consideration of benefits detailed in para (d) given below.

d) MSEs registered with any of the agencies mentioned in para (a) are entitled for the following benefits provided they submit a valid Udyog Aadhar Memorandum/ Udyam Registration Certificate:

- i. MSEs registered with any of the agencies for the item tendered will be exempted from payment of Earnest Money.
- ii. In tenders, participating MSEs quoting a price within price band of L1 + 15% shall be allowed to supply a portion of the requirement by bringing down their price to L1 price, in a situation where L1 price is from someone other than a MSE and such MSEs can be together ordered up to 25% value out of the net procurement quantity.
- iii. A minimum of 4% of total procurement, within the 25% earmarked for MSEs will be from MSEs owned by Scheduled Caste/ Scheduled tribe (SC/ST) Entrepreneurs. In the event of failure of such MSEs to participate in the tender process or meet tender requirements and L-1 price, 4% earmarked from MSEs owned by Scheduled Caste/ Scheduled Tribe (SC/ST) Entrepreneurs be met from other MSEs.
- iv. A minimum of 3% of total procurement, within the 25% earmarked for MSEs will be procured from women owned MSEs.
- v. In case tendered item is non-splitable or non-dividable, etc. Purchaser may award the full/complete supply of total tendered value to MSE quoting price within price band L1+15%, considering spirit of policy for enhancing the Govt. procurement from MSE.

Traders and agents are not eligible to avail the benefits extended under the Public Procurement Policy for MSEs.

e) An MSE shall be considered as that owned by SC/ST in following cases:

- i) In case of proprietary MSE, proprietor(s) shall be SC/ST.
- ii) In case of partnership MSE, the SC/ST partners shall be holding at least 51% shares in the unit.
- iii) In case of Private Limited Companies, at least 51% share shall be held by SC/ST promoters.

- f) In case, the tenderer is a Micro or Small Enterprises (MSE), the tenderer shall also furnish the following details in their offer:
- i) The category of the tenderer:
    - a) Whether vendor is Micro Enterprise or
    - b) Whether vendor is Small Enterprise.
  - ii) Each of the above categories must further mention the sub-classification whether the tenderer is an enterprise -
    - a) Owned by Scheduled Castes (SC)
    - b) Owned by Scheduled Tribes (ST)
    - c) Owned by women entrepreneurs
    - d) Owned by other than the above three categories.
  - iii) Confirm the following:
    - a) Whether documentary proof of being registered with any of the specified agencies indicated in Para 13(a) above has been submitted with their offer.
    - b) Whether the terminal date of validity of the registration with the specified agencies has been indicated in their offer.
  - g) In case, the tendered item is restricted for placement of bulk orders on approved sources, then the criteria for placement of orders on MSEs under the Public Procurement Policy for MSEs will additionally require that the MSE firms are one of the valid approved sources for the tendered item.
  - h) The tenderers who are large Scale vendors of Railway Units or who come under consortia of MSEs (as vendors to Railway Units) formed by NSIC, are also required to upload with their offers, the procurement and percentage of sub-contract to be made from MSEs for goods to be supplied against this tender, and also furnish the details as in para 6 above for the portion sub- contracted to MSEs.

Declaration of Udyog Adhar Memorandum (UAM)/ Udyam Registration Certificate (URC) number by vendor is **mandatory**. Accordingly, the Tenderers who fail to submit UAM number shall not be avail the benefits available to MSE as contained in Public Procurement Policy for MSEs Order, 2012 or latest issued by MSME, for tenders invited electronically through CPPP.

Dated:

Authorised Signatory :

Name :-

Designation :-

Seal :-

## APPENDIX -15

### ANNEXURE VII - MANDATORY CONDITIONS TO BE SATISFIED BY ANY TENDERER FROM A COUNTRY WHICH SHARES A LAND BORDER WITH INDIA

(This annexure is to be signed and stamp and submitted/uploaded by Tenderer along with the bid)

- A.** The tender shall be governed by the following terms and conditions:
- I. Any Tenderer from a country which shares a land border with India will be eligible to bid in this tender only if the Tenderer is registered with the Competent Authority as specified in Order (Public Procurement No.1) F.No.6/18/2019-PPD Dated 23.07.2020 issued by Ministry of Finance, Department of Expenditure, Public Procurement Division and as amended from time to time. Such registration should be valid at the time of submission and acceptance of bids.
  - II. "Tenderer" (including the term 'tenderer', 'consultant' or 'service provider' in certain contexts) means any person or firm or company, including any member of a consortium or joint venture (that is an association of several persons, or firms or companies), every artificial juridical person not falling in any of the descriptions of Tenderers stated hereinbefore, including any agency branch or office controlled by such person, participating in a procurement process.
  - III. "Tenderer from a country which shares a land border with India" for the purpose of this Order means: -
    - a. An entity incorporated, established or registered in such a country; or
    - b. A subsidiary of an entity incorporated, established or registered in such a country; or
    - c. An entity substantially controlled through entities incorporated, established or registered in such a country; or
    - d. An entity whose beneficial owner is situated in such a country; or
    - e. An Indian (or other) agent of such an entity; or
    - f. A natural person who is a citizen of such a country; or
    - g. A consortium or joint venture where any member of the consortium or joint venture falls under any of the above
  - IV. The beneficial owner for the purpose of (iii) above will be as under:
    1. In case of a company or Limited Liability Partnership, the beneficial owner is the natural person(s), who, whether acting alone or together, or through one or more juridical person, has a controlling ownership interest or who exercises control through other means.

Explanation-

      - a) "Controlling ownership interest" means ownership of or entitlement to more than twenty-five percent of shares or capital or profits of the company;
      - b) "Control" shall include the right to appoint majority of the directors or to control the management or policy decisions including by virtue of their shareholding or management rights or shareholders agreements or voting agreements;
    2. In case of a partnership firm, the beneficial owner is the natural person(s) who, whether acting alone or together, or through one or more juridical person, has ownership of entitlement to more than fifteen percent of capital or profits of the partnership;
    3. In case of an unincorporated association or body of individuals, the beneficial owner is the natural person(s), who, whether acting alone or together, or through one or more juridical person, has

ownership or entitlement to more than fifteen percent of the property or capital or profits of such association or body of individuals;

4. Where no natural person is identified under (1) or (2) or (3) above, the beneficial owner is the relevant natural person who holds the position of senior managing official;
  5. In case of a trust, the identification of beneficial owner(s) shall include identification of the author of the trust, the trustee, the beneficiaries with fifteen percent or more interest in the trust and any other natural person exercising ultimate effective control over the trust through a chain of control or ownership.
- V. An Agent is a person employed to do any act for another, or to represent another in dealings with third person.
- VI. The successful Tenderer shall not be allowed to sub-contract works to any contractor from a country which shares a land border with India unless such contractor is registered with the Competent Authority.
- VII. Certificate regarding compliance: **A certificate shall be provided by Tenderers in the tender documents regarding their compliance with these clauses.** If such certificate given by a Tenderer whose bid is accepted is found to be false, this would be a ground for immediate termination and further legal action in accordance with law.
- VIII. Validity of registration: In respect of tenders, registration should be valid at the time of submission of bids and at the time of acceptance of bids. If the Tenderer was validly registered at the time of acceptance / placement of order, registration shall not be a relevant consideration during contract execution.
- B. Not with standing above, the terms and conditions mentioned above will not apply to Tenderers from those countries (even if sharing a land border with India) to which the Government of India has extended lines of credit or in which the Government of India is engaged in developing projects.

*"I have read the clause regarding restrictions on procurement from a Tenderer of a country which shares a land border with India and on sub-contracting to contractors from such countries; I certify that this Tenderer is not from such a country or, if from such a country, has been registered with the Competent Authority and will not sub-contract any work to a contractor from such countries unless such contractor is registered with the Competent Authority. I hereby certify that this Tenderer full fills all requirements in this regard and is eligible to be considered. [Where applicable, evidence of valid registration by the Competent Authority shall be attached.]"*

Dated:

Authorised Signatory :

Name :-

Designation :-

Seal :-

(On Letter Head of the Tenderer)

**APPENDIX -16**

**UNDERTAKING**

We hereby declare and accept that if we withdraw or modify our bid during the period of validity, or if we are awarded the contract and we fail to sign the contract, or fail or submit the performance security before the deadline defined in the Tender, we agree for suspension for period of TWO year from participating in GeMs and in any tender of the corporation which shall be binding on us and we shall not appeal against the same.

Dated:

Authorised Signatory :

Name :-

Designation :-

Seal :-

### **Instructions for Online Bid Submission:**

The Tenderers are required to submit soft copies of their bids electronically on the CPP Portal, using valid Digital Signature Certificates. The instructions given below are meant to assist the Tenderers in registering on the CPP Portal, prepare their bids in accordance with the requirements and submitting their bids online on the CPP Portal.

More information useful for submitting online bids on the CPP Portal may be obtained at: <https://eprocure.gov.in/eprocure/app>.

### **Registration:**

1. Tenderers are required to enrol on the e-Procurement module of the Central Public Procurement Portal (URL: <https://eprocure.gov.in/eprocure/app>) by clicking on the link "Online Tenderer Enrolment" on the CPP Portal which is free of charge
2. As part of the enrolment process, the Tenderers will be required to choose a unique username and assign a password for their accounts.
3. Tenderers are advised to register their valid email address and mobile numbers as part of the registration process. These would be used for any communication from the CPP Portal.
4. Upon enrolment, the Tenderers will be required to register their valid Digital Signature Certificate (Class II or Class III Certificates with signing key usage) issued by any Certifying Authority recognized by CCA India (e.g. Sify / nCode / eMudra etc.), with their profile.
5. Only one valid DSC should be registered by a Tenderer. Please note that the Tenderers are responsible to ensure that they do not lend their DSC's to others which may lead to misuse.
6. Tenderer then logs in to the site through the secured log-in by entering their user ID/Password and the password of the DSC/e-Token.

### **Searching For Tender Documents:**

1. There are various search options built in the CPP Portal, to facilitate Tenderers to search active tenders by several parameters. These parameters could include Tender ID, Organization Name, Location, Date, Value, etc. There is also an option of advanced search for tenders, wherein the Tenderers may combine a number of search parameters such as Organization Name, Form of Contract, Location, Date, Other keywords etc. to search for a tender published on the CPP Portal.
2. Once the Tenderers have selected the tenders they are interested in, they may download the required documents/tender schedules. These tenders can be moved to the respective 'My Tenders' folder. This would enable the CPP Portal to intimate the Tenderers through SMS/e-mail in case there is any corrigendum issued to the tender document.
3. The Tenderer should make a note of the unique Tender ID assigned to each tender, in case they want to obtain any clarification/help from the Helpdesk.

### **Preparation of Bids:**

- a. Tenderer should take into account any corrigendum published on the tender document before submitting their bids.
- b. Please go through the tender advertisement and the tender document carefully to understand the documents required to be submitted as part of the bid. Please note the number of covers in which the bid documents have to be submitted, the number of documents - including the names and content of each of the document that need to be submitted. Any deviations from these may lead to rejection of the bid.
- c. Tenderer, in advance, should get ready the bid documents to be submitted as indicated in the tender document / schedule and generally, they can be in PDF / XLS / RAR / DWF/JPG formats. Bid documents may be scanned with 100 dpi with black and white option which helps in reducing size of the scanned document.
- d. To avoid the time and effort required in uploading the same set of standard documents which are required to be submitted as a part of every bid, a provision of uploading such standard documents (e.g. PAN card copy, annual reports, auditor certificates etc.) has been provided to the Tenderers. Tenderers can use "My Space" or "Other Important Documents" area available to them to upload such documents and keep it as a repository.

Note: My Documents space is only a repository given to the Tenderers to ease the uploading process. If Tenderer has uploaded his Documents in My Documents space, this does not automatically ensure these Documents being part of Technical Bid.

**Submission of Bids:**

1. Tenderer should log into the site well in advance for bid submission so that they can upload the bid in time i.e. on or before the bid submission time. Tenderer will be responsible for any delay due to other issues.
2. The Tenderer has to digitally sign and upload the required bid documents one by one as indicated in the tender document.
3. Tenderer has to select the payment option as “offline” to pay the tender fee/EMD as applicable and enter details of the instrument.
4. Tenderer should prepare the EMD as per the instructions specified in the tender document. The original should be posted/ couriered/given in person to the concerned official, latest by the last date of bid submission or as specified in the tender documents. The details of the DD/any other accepted instrument, physically sent, should tally with the details available in the scanned copy and the data entered during bid submission time. Otherwise the uploaded bid will be rejected.
5. Tenderers are requested to note that they should necessarily submit their financial bids in the format provided and no other format is acceptable. If the price bid has been given as a standard BoQ format with the tender document, then the same is to be downloaded and to be filled by all the Tenderers. Tenderers are required to download the BoQ file, open it and complete the white coloured (unprotected) cells with their respective financial quotes and other details (such as name of the Tenderer). No other cells should be changed. Once the details have been completed, the Tenderer should save it and submit it online, without changing the filename. If the BoQ file is found to be modified by the Tenderer, the bid will be rejected.
6. The server time (which is displayed on the Tenderers’ dashboard) will be considered as the standard time for referencing the deadlines for submission of the bids by the Tenderers, opening of bids etc. The Tenderers should follow this time during bid submission.
7. All the documents being submitted by the Tenderers would be encrypted using PKI encryption techniques to ensure the secrecy of the data. The data entered cannot be viewed by unauthorized persons until the time of bid opening. The confidentiality of the bids is maintained using the secured Socket Layer 128 bit encryption technology. Data storage encryption of sensitive fields is done. Any bid document that is uploaded to the server is subjected to symmetric encryption using a system generated symmetric key. Further this key is subjected to asymmetric encryption using buyers/bid openers’ public keys. Overall, the uploaded tender documents become readable only after the tender opening by the authorized bid openers.
8. The uploaded tender documents become readable only after the tender opening by the authorized bid openers.
9. Upon the successful and timely submission of bids (ie after Clicking “Freeze Bid Submission” in the portal), the portal will give a successful bid submission message & a bid summary will be displayed with the bid no. and the date & time of submission of the bid with all other relevant details.
10. The bid summary has to be printed and kept as an acknowledgement of the submission of the bid. This acknowledgement may be used as an entry pass for any bid opening meetings.

**Assistance to Tenderers:**

1. Any queries relating to the tender document and the terms and conditions contained therein should be addressed to the Tender Inviting Authority for a tender or the relevant contact person indicated in the tender.
2. Any queries relating to the process of online bid submission or queries relating to CPP Portal in general may be directed to the 24x7 CPP Portal Helpdesk Nos. 0120-4200462, 0120-4001002

Sr. No.	Mandatory/Pre-Qualification Criteria	Complied / Not Complied	Provide details
B1			
1	All tenderers are required to submit Rs. 600/- (Including GST), towards cost of Tender documents, if down-loaded from the website of the Corporation/CPPP. (All SSI units/ MSE Vendors are exempted from Tender Cost on submission of valid Udyog Aadhaar Memorandum (UAM)/Udyam Registration against tender for the items/nature of business/ type of services specified there in the UAM/ Udyam Registration). The cost of Tender documents for Rs. 600/- (Including GST), can be submitted <b>only through online payment gateway available at <a href="http://www.alimco.in">www.alimco.in</a> and submit scan copy of the e-receipt of the same along with TC bid</b>		
2	The person signing the bid should be duly authorised representative of the firm/company whose signature should be verified and certificate of authority should be submitted. The poser or authorisation or any other document consisting of adequate proof of the ability of the signatory to bind the firm/company should be annexed to the bid.		
3	Tender documents with proper seal and signature of authorized person on each page of the bid must be submitted.		
4	The Complete specifications, Make/Model/Brand consisting of whole plant & its accessories offered on parameters specified as per Annexure-A, must be mentioned. The details with values for individual specifications/parameters desired must be indicated at Annexure 'B1 & B2' to this tender document.		
5	Copy of GST Registration Certificate, duly signed & stamped.		
6	The tenderer should have an average annual turnover of not less than 30% of estimated value during the last 03 financial years i.e. FY: 2017-18, 2018-19 & 2019-20. In order to authenticate, <b>a certificate regarding average turnover during the above last three financial years from a qualified Chartered Accountant clearly mentioning the UDIN number in the certificate is required to be furnished along with TC-Bid.</b>		
7	Copy of income tax return for the last three financial years, i.e. FY- 2017-18, 2018-19 & 2019-20, duly signed & stamped.		
8	Only OEMs with relevant expertise are allowed to bid for the whole plant (on turn-key basis) mentioned in the tender document. The declaration/ certificate is required from bidder. <b>If in any case OEM and authorised Distributer/Dealer participate in the same tender, then all such offers shall be treated as single offer and the lowest price quoted among them will be considered.</b>		
9	Vendor must have supplied at least five CNC Laser Tube Cutting machines in the last three years. Purchase order copies of <b>five</b> machines and their commissioning certificates to be submitted. Performance Certificates of 03 separate users, issued within 3 years from date of opening of this tender, shall be submitted.		
11	Undertaking stating that "The delivery, installation and		



	commissioning of the plant (on turn-key Basis) must be completed within the stipulated period as indicated in the tender or specified at Annexure-A, from the date of placement of PO/work contract” in the format enclosed at Appendix-1.		
12	The tenderer should submit an undertaking that his/her firm has not been debarred/ blacklisted/ terminated/banned to participate in the tender by any Govt. Institution, PSUs, and State Govt. or Central Govt. Deptt. in the format enclosed at Appendix-2.		
13	The tenderer should submit an undertaking that his/her Offer is valid for acceptance for 120 days from the date of opening of TC Bids in the format enclosed at Appendix-3.		
14	Undertaking to the effect that all the tender terms & conditions are acceptable to the bidder in the format enclosed at Appendix-4.		
15	Undertaking to the effect that a Warranty Performance Bank Guarantee (PBG) of 3% of the order value, valid for warranty/defect liability period & claim submission date will be submitted after the commissioning of the plant (on turn-key basis). The security deposit shall be released on receipt of 3% PBG valid for warranty period in the format enclosed at Appendix-5.		
16	The tenderer should submit an undertaking that his/her firm shall provide Security Deposit within 14 days of releasing PO in the format enclosed at Appendix-6.		
17	The tenderer should submit an undertaking that his/her firm shall provide the complete training regarding operation & maintenance of the Whole Plant (On turn-key Basis) & its accessories in the format enclosed at Appendix-7.		
18	The tenderer should submit an undertaking for unconditional acceptance to replace the supplies if rejected at the destination in the format enclosed at Appendix-8.		
19	Undertaking to be submitted by the tendered that “They should undertake that they will execute comprehensive AMC including spares and labour for the period of 03 years after the expiry of warranty/defect liability period as per the requirement of ALIMCO and the AMC shall not exceed 6%, 7% & 8% of basic value of the machine/plant during 3 <sup>rd</sup> , 4 <sup>th</sup> & 5 <sup>th</sup> year respectively from the date of successful installation & commissioning of the machine/plant/item/equipment” <b>in the format enclosed at Appendix-9 and 9/1</b>		
20	Undertaking to be submitted by the tenderer that “payment terms mentioned at Para No-16 of this tender document (i.e. Terms of Payment) is acceptable” in the format enclosed at Appendix-10.		
21	Tenderers are required to submit “Tender Acceptance Letter” in the format enclosed at Appendix- 11.		
22	Tenderers are required to submit “Undertaking” regarding availment of GST and matching of Input credit in the format enclosed at Appendix-12.		
23	Tenderers are required to submit duly filled Annexure ‘B1& B2’, enclosed herewith.		
24	Latest Government of India guidelines on “Purchase Preference to Make in India” placed at Appendix 13.		
25	An affidavit to be sought from L1 party regarding, a) The party has not been debarred/ blacklisted/ terminated/banned by any Govt. Institution, PSUs, and State Govt. or Central Govt. Deptt.		

	b) The party has not supplied the same Machine /System at a cost lower than the cost offered to ALIMCO to any government / semi-government /reputed private organisation in India		
26	a)Self certification that the items offered meets the local content requirement for 'Class-I local supplier/ 'Class-II local supplier, as the case may be as per Clause 1 of Appendix 13. – Bidder to confirm		
	b)Certificate from the statutory auditor or cost auditor of the company (in case of companies) or from a practicing cost accountant or practicing chartered accountant (in respect of supplies other than companies giving the percentage of local content as per Clause 1 of Appendix 13 – Bidder to furnish.		
27	Latest Government of India guidelines on “PUBLIC PROCUREMENT POLICY FOR GOODS PRODUCED AND SERVICES RENDERED BY MICRO AND SMALL ENTERPRISES (MSES):” placed at Appendix 14.		
28	Latest Government of India guidelines “Mandatory Conditions to be satisfied by any bidder from a country which shares a land border with India” placed at Appendix 15		
a)	Self attested copy of Appendix 15 mandatory conditions to be satisfied by any bidder from a country which shares a land border with India. – Bidder to confirm		
b)	Certificate of compliance of clauses of Appendix 15, clause A VII. – Bidder to confirm		
c)	Certification as per last paragraph of Appendix 15 mandatory conditions to be satisfied by any bidder from a country which shares a land border with India. – Bidder to confirm		
d)	The Appendix 15 must be signed and stamp and submitted/uploaded by Bidder along with the bid. To be read in conjunction with Order (Public Procurement No. 2) F.No.6/18/2019-PDD dated 23rd July 2020 issued by Ministry of Finance, Department of Expenditure, Public Procurement Division. – Bidder to Confirm		

**“CNC Laser Tube Cutting Machine with full safety enclosure Class-I”**  
**(On Turnkey Basis)**

**Code No.**

**Total Qty. – 08 sets**

<b>1</b>	Artificial Limbs Manufacturing Corporation of India (ALIMCO) G.T. ROAD, Kanpur-209217 (U.P.)	<b>Qty-03set</b>
<b>2</b>	ALIMCO Auxiliary Production Center (AAPC) Plot No. 8, Peenya Plant Station Near Jalasaudha, PO-Jalahalli BANGALORE-560013	<b>Qty-01set</b>
<b>3</b>	ALIMCO Auxiliary Production Center (AAPC) S-3/66 Mancheswar Industrial Area, BHUBANESWAR-751010	<b>Qty-01set</b>
<b>4</b>	ALIMCO Auxiliary Production Center(AAPC) Plot No,40, 106 &107 Ricchai Industrial Area, Maharajpur, JABALPUR-482010	<b>Qty-01set</b>
<b>5</b>	ALIMCO Auxiliary Production Center,(AAPC) Plot No ,A-1,A-2,A-3 Industrial Focal Point, CHANALON, Mohali-140 103 PUNJAB	<b>Qty-01set</b>
<b>6</b>	ALIMCO Auxiliary Production Center(AAPC) Plot No. 16/2, Post – Manpura, Dewas Road, UJJAIN (M.P.) – 456 010	<b>Qty-01set</b>

**Scope:-**

1. Laser Tube Cutting System.
2. CNC System and Software.

**PURPOSE:-**

All types of Tube (material & thickness as mentioned) to be cut for ALIMCO products through this CNC Laser Tube Cutting Machine.

S. No.	Description of Requirement	Required	Complied / Not Complied	Provide details
1	Cutting tube details			
1.1	Laser cutting of Round tubes	At-least from $\phi$ 15-38 mm		
1.2	Laser cutting of rectangular tubes	At-least up to 65mmx38 mm		
1.3	Loadable bar / tube length	At-least up to 6250 mm		
1.4	Material: Iron (mild steel), SS, Al, Cu, Brass to be cut by laser	Confirm		
1.5	Cutting thickness (MS Tube)	At-least up to 2.5 mm		
1.6	Cutting thickness (SS Tube)	At-least up to 2 mm		
1.7	Cutting thickness (Aluminum Tube)	At-least up to 2 mm		
1.8	Capacity of loading cradle	Min. 1500 Kg		
1.9	Laser tube cutting system, consisting of :			
1.9.1	Measurement and automatic bar loading system, tube guiding and supporting device	Confirm		
1.9.2	Electrical cabinet	Confirm		
1.9.3	Safety devices i.e. guard, Alarm system etc.	Confirm		
1.9.4	Guide steady near cutting head with electronically synchronized chuck, CNC motorized axial positioning, including full stock clamping independent adjustment jaws.	Confirm		
1.9.5	Integration of automatic loader for tubes (round, square, rectangle and flat oval tubes) including positioning / orientation system.	Confirm		
1.9.6	Automatic worked piece discharge-support system for scrap pieces.	01 Set		
1.9.7	Parts collecting table with conveyor and horizontal motorized chains covered with rubber.	01 Set		
2	Controller:			
2.1	Siemens/Fanuc/Beck-Hoff/ABB/BR Automation/Mitsubishi	Vendor to specify		
2.2	Laser safety window with full safety enclosure Class-1	Confirm		
2.3	TFT color touch monitor	Min 19"		
2.4	USB Port for program loading with source key	Confirm		
2.5	Ethernet connectivity through network card	Confirm		
3	Laser Source			
3.1	Fiber laser source with pulse generator, control panel and control	Confirm		
3.2	Laser source. Specification of Laser Source to be specified.	Fiber laser		
3.3	Fiber laser source nominal power	Minimum 2000 W		
3.4	Fiber Laser Make	IPG/Trumpf/AMADA		
3.5	Lens holder	01 Set		
3.6	Chiller with closed circuit for laser source, Specify make of Chiller unit. Specify quality, quantity of water requirement, temperature of inlet cooling water. Chemical composition of additives and rust inhibitors if added to water, to be specified. All these items are in scope of Tenderer including demineralised water. Additives and rust inhibitors to be supplied for one year requirement are in scope of Tenderer.	Confirm & Specify		

3.7	Filtered Fume extractor with high efficiency filter cartridges. Hourly air flow rate Min. 1500 m <sup>3</sup> /h. Details to be specified. Specify make of filter. Ducting from blower out let as per site condition to be quoted in rupees per meter length in the Price Bid. Self-cleaning Filter cartridge with compressed air pulsing shall be provided. Tenderer to explain the system. Spark Arrestor for protection of the filter chamber from sparks and coarse particles. The exhaust air must meet the Air Quality Index (AQI) in the working area as per government norms issued by Central Board for AQI quality "GOOD".	Confirm & Specify		
3.8	Beam delivery system details	Confirm & Specify		
3.9	Cut Accuracy	As per ISO 9013 or latest		
3.10	Laser Beam Alignment Kit	Confirm		
3.11	Cutting head should have automatic positional check and precise cutting head focus arrangement. Non-Contact Capacitive Height sensing device. Cutting Head should be of reputed OEM make.	Confirm		
3.12	Cutting head should have protection against unintended crash with work piece.	Confirm		
3.13	The cutting lens shall be cleaned without disassembly of the complete cutting head. Specify make of lens.	Confirm		
3.14	Machine shall have automatic corner control mechanism such that it selects appropriate laser parameters while executing corner cutting/fine reduced edges.	Confirm		
3.15	Auto-interruption of laser beam during abnormal functioning of machine system.	Confirm		
3.16	International Safety Certifications, to which the machine complies, shall be furnished.	Confirm & Specify		
<b>4</b>	<b>Basic Machine Features</b>			
4.1	The laser and electrical cabinet shall have safety enclosure and same should be air conditioned. This is in scope of Vendor.	Confirm		
4.2	Rigid and Stress relieved Machine Frame with hardened guides.	Confirm		
4.3	Vendor to specify make of Drive System and details of transmission system.	Confirm & Specify		
4.4	Single cutting head with common lens mechanism. Specify make of cutting Head. The cutting head shall be able to cut bevels up to an angle of 45 degrees.	Confirm		
4.5	Non-Contact Capacitive Height sensing device	Confirm		
4.6	Programmable cutting gas pressure selection	Confirm		
4.7	Automatic Tube referencing System	Confirm		
4.8	Gravity Conveyor chute and slag Trolley for slag and smaller parts	Confirm		
4.9	Programmable nozzle cleaning facility	Confirm		
4.10	Automatic Hole Piercing System	Confirm		
<b>5.</b>	<b>CNC System, Control Panel, Hardware, Software &amp; IT Systems. Make of CNC controller. Size of LCD color monitor to be specified. CNC system provided shall be capable of:</b>	Confirm & Specify		
<b>a)</b>	Rotary Axis clockwise & anti-clockwise rotation	Confirm & Specify		
<b>b)</b>	Y-Axis forward & backward movement	Confirm & Specify		

c)	Z-Axis for up & down movement	Confirm & Specify		
d)	Bevel Axis 45°	Confirm & Specify		
5.1	Offline programming system should have a CAD module to design and draw a workable piece. It should be able to import IGES/STEP/DXF file for program generation.	Confirm		
5.2	Software should have library of bend cut management.	Confirm		
5.3	CAM system for automatically applying the cutting parameters on every part geometry and decide the operating sequence, cutting strategy (auto nesting).	Confirm		
5.4	Integrated parametric three-dimension software suited to design and draw tubes of any type and section and to automatic generate the single relevant components	Confirm		
5.5	Post processor for loading of program to the machine	Confirm		
5.6	Perpetual PC license of the software for operating and checking on PC. Make of Cutting Software.	Confirm/Specify		
5.7	System configuration- As per software requirement; with following minimum requirements i)Compatible O.S. Genuine Windows 10 Professional 64 bit or above ii) Processor: Inteli7 or Xeon E3, 3.2Ghz or faster iii) Min. 1920*1080 resolution, monitor size- 23" (min.) iv) Storage: SSD with at least 1 TB v) Memory: 32 GB extendable up-to 64 GB vi) NVIDIA graphic card Min. 8 GB memory	Confirm		
5.8	Make of CNC System	Specify		
5.9	3D graphical simulation of part program to check the correct location of the work and estimate the hourly productivity.	Confirm		
	<b>GENERAL OPERATING CONDITION</b>			
<b>6</b>	Electrical should be designed for			
6.1	3 Phases 415V ( $\pm$ 10%)	Confirm		
6.2	Frequency 50 Hz ( $\pm$ 3%)	Confirm		
6.3	Total Electrical Power required (In KW)	Specify and Confirm		
6.4	Protection level	IP54 or better		
<b>7</b>	Complete electrical system with tropicalization for Indian condition +0°C to +50°C temp and RH 100%	Confirm		
<b>8</b>	Service: The authorized Service Partners in India (Name & Address) must be certified by manufacturer and shown in the quotation	Confirm		
<b>9</b>	Machine to have capability to handle voltage and current fluctuation and power backup required for minimum 15 mins. for CNC control system. UPS of 15 min. battery back and Isolation Transformer to be provided.	Confirm		
10	Spares, Consumables & Accessories: (all following sets of items to be provided against each individual machine separately)	Confirm		
a)	Limit switches (02 Sets)	Confirm		
b)	CNC Panel Keys (02 Sets)	Confirm		
c)	Fuses (05 Set of each type of fuse)	Confirm		
d)	Protection Mirror lens (10 Nos.)	Confirm		
e)	Cutting Lens (02 Nos)	Confirm		
f)	Ceramic ring (04 Sets)	Confirm		
g)	Cutting nozzles – Total 50 numbers. (Tenderer to specify quantity of different nozzle sizes)	Confirm		
h)	Protective Eyewear for operators(10 numbers)	Confirm		
i)	Protective Gloves for operations (20 Sets)	Confirm		
j)	Lens cleaning paper, cloth, cleaning bud(5 Sets)	Confirm		
k)	High purity Acetone (100ml)	Confirm		

11	Supplier shall provide undertaking for availability of machine spares up to minimum 10 years from date of supply.	Confirm		
12	Documentation: Following documents (3 sets of hard copy and 1 set of soft copy) along with delivery will be required	Confirm		
12.1	Operating instruction	Confirm		
12.2	Quality Test records	Confirm		
12.3	Preventive maintenance instructions	Confirm		
12.4	Lubrication chart & parameter list	Confirm		
12.5	Lifting instruction mentioned in packing list.	Confirm		
12.6	Detailed invoice and packing list of all items and all other accessories enclosed in respective boxes	Confirm		
13	Training at site (for a team as decided)			
13.1	Operation and Programming	14 Days		
13.2	Preventive maintenance training	10 Days		
14	Prove-out:			
14.1	Vendor to perform complete trial run and prove out	Confirm		
14.2	Vendor has to prove-out cutting of items after successful installation and commissioning at site for a period of 04 days having eight-hour shifts. Raw material shall be provided by Company. Drawings Enclosed Successful vendor to prepare AutoCAD drawing of the components to be proved out	Confirm		
15	Delivery Period (including, Installation & Commissioning and training)	6 months		
16	Packaging and Transportation is in the scope of vendor.	Confirm		
17	Installation and Commissioning should be done within 21 days on receipt of machine at Kanpur by the vendor. All necessary things to maintain precision & accuracy shall be done by vendor at the time of handover the machine.	Confirm		
18	Tenderers shall have supplied at least 5 similar capacity Laser Tube cutting machine in Govt. Sector/ Private Sector in the last three years. (PO copies and Commission /Completion Certificates/ proof of the same to be furnished). Performance Certificate of 03 users issued within last 03 years.	Confirm		
19	Warranty	2 Years		
20	<b>DELIVERY PERIOD INCLUDING INSTALLATION &amp; COMMISSIONING AND TRAINING :</b> The delivery period including installation & commissioning and training at site of all of the machines at the destination mentioned in Para 1 on page no. 02 of the tender documents will be 06 months from the date of placement of Purchase Order/work contract	Confirm		
21	<b>WARRANTY:</b> The entire machine inclusive of all system/accessories should be covered under warranty for a period of 24 months (min.) from the date of successful commissioning (Warranty shall specifically cover laser source)	Confirm		
	<b>Note:-</b>	Confirm		
1	The loading/unloading of machine & other components of supply and their handling at destination site is in the scope of vendor.	Confirm		
2	Supply to be done on Turnkey Basis. Company shall provide electrical supply point near to the place of installation.	Confirm		
3	Machine shall be supplied with 3 sets of comprehensive operation and maintenance manual, Spare part catalogue, electrical circuits, manuals of bought out imported and indigenously purchased items in hard copy and soft copy.	Confirm		

4	Breakdown calls to be attended within 72 hrs. Physically or through tele-diagnostic	Confirm		
5	Machine foundation details and drawings with specifications to be provided by the tenderer.	Confirm		
6	Total power consumption (in kW) to be provided by the tenderer.	Confirm		
7	The Bus-bar trunking (BBT) for electricity has been provided at 8.5 meter height. Sufficient suitable cable, cable tray, Circuit breaker, panel fittings to connect the machine from power source is in vendor's scope. Suitable power backup for failsafe operation of machine in the event of Power failure is in vendor's scope	Confirm		
8	Compressed air pipeline is available in the work center (air pressure will be available approx. 5.5 to 6 bar). All necessary fittings, air dryer, air booster as per machine requirements, is in vendor's scope. Tenderers to specify average consumption of compressed air.	Confirm		
9	Vendor to arrange any foundation work/grouting of anti-vibration pads or foundation bolts for the installation of machine.	Confirm		
10	Consumables required for smooth functioning of machine for a period of one year is in scope of vendor.	Confirm		
11	Vendor shall provide cutting gas bank both for cutting MS tubes and SS/Al, tubes. Vendor to submit quality of cutting gas, per day consumption and nearby source of cutting gas. A bank of 15 cylinders of cutting gas for cutting MS and 5 cylinders of cutting gas for SS/Al shall be provided with pipeline, pressure Regulators, non-return valves, etc.	Confirm		
12	Spare filled cylinders 15 numbers for cutting MS and 5 cylinders for cutting SS/Al to be provided by vendor.	Confirm		
13	Proper earthing of plant/machinery is in vendor scope. If separate earthing is required for machine/plant than earthing pit is in vendor scope.	Confirm		
14	Vendor to specify requirement of demineralised water. One year requirement of demineralised water is in scope of Vendor.	Confirm		
15	Voltage Stabilizer and Ultra isolation Transformer are in scope of Vendor.	Confirm		
16	Vendor to specify minimum inventory of critical spares to be maintained for 02 years (Manufactures recommended list of spares).	Confirm		
17	Any related civil work is in the scope of vendor.	Confirm		
18	Vendor should undertake that they will execute comprehensive AMC including spares and labour for the period of 03 years after the expiry of warranty/defect liability period as per the requirement of ALIMCO and the AMC shall not exceed 6%, 7% & 8% of basic value of the machine/plant during 3 <sup>rd</sup> , 4 <sup>th</sup> & 5 <sup>th</sup> year respectively from the date of successful installation & commissioning of the machine/plant/item/equipment.	confirm		
19	Vendor shall take full responsibility for the adequate stability and safety of all site operations and installation & commissioning as per the latest safety manuals published by Indian Standards Institution Statutory rules regulations and provisions of order conditions etc. and in case of default, Vendor shall solely be responsible and indemnify the corporation for any loss or damage caused to the ALIMCO for any violation of concerned laws.	Confirm		



Tender Inviting Authority: **ALIMCO KANPUR (ANNAXURE C1)**

Name of Work: **Regarding Supply, Installation & Commissioning of CNC Laser Tube Cutting System on Turnkey Basis**

Contract No: **PT/OT/05/AY**

Enter GSTIN No	
Name of the Bidder/ Bidding Firm / Company :	

**PRICE SCHEDULE**

(This BOQ template must not be modified/replaced by the bidder and the same should be uploaded after filling the relevant columns, else the bidder is liable to be rejected for this tender. Bidders are allowed to enter the Bidder Name and Values only )

**Note:**

A) The basic Price/rate, Taxes, Packing & Forwarding charges and Freight charges must be mentioned separately & Specifically. The offer quoted inclusive of Taxes, Packing & Forwarding charges and freight charges will summarily be rejected. The same is essential keeping in view the applicability of GST proposed to be implemented w.e.f. 01.07.2017 by the Government. The impact (%age) of GST on item,/items will be admissible as applicable on the basic rate being statutory levy only during currency of Purchase Order/Contract against party's request alongwith necessary documents in support of their claim/amendments.

B) Giving HSN code, GSTIN & GST is mandatory and the bills after placement of order should mention the same HSN code, GSTIN & GST. Providing correct HSN code, GSTIN & GST is the responsibility of the vendor and ALIMCO is no way responsible for any subsequent interpretation/ order by the tax authorities.

NUMBER #	TEXT #	TEXT #	NUMBER #	TEXT #	NUMBER	NUMBER #	NUMBER	NUMBER	NUMBER	NUMBER	TEXT	TEXT	NUMBER	NUMBER	NUMBER #	NUMBER #
Sl. No.	Item Description	Item Code / Make	Quantity	Units	HSN Code/ SAC Code	BASIC RATE Per Unit In Rs (B)	Total Basic Cost (TBC) in Rs (B)	Freight Charges (FC) on TBC in (%) (C)	Freight Charges (Rs) (C)	Packing & Forwading Charges (PnF) on TBC in (%) (D)	Packing & Forwading Charges (Rs) (D)	Sub Total (TBC+ FC+PnF) in Rs. (E)	GST on Sub Total(E) in (%) (F)	GST in Rs. (F)	TOTAL AMOUNT Without Taxes (Sub Total) Rs. P	TOTAL AMOUNT With Taxes in Rs. P
1	2	3	4	5	6	7	8	9	10	11	12	13	14	15	16	16
1.01	Regarding Supply of CNC Laser Tube Cutting System on (Turnkey Basis) as per the details enclosed at Annexure-A	Item1	3	Set		-	-	-	-	-	-	0.00		-	0.00	0.00
1.02	Installation & Commissioning Charges including Civil, Electrical work on turnkey basis for satisfactory commissioning of the machine/equipment (if any)	Item2	1	Set		-	-	-	-	-	-	0.00		-	0.00	0.00
1.03	Supply of any other additional items (other than specified at Annexure-A) which are necessarily required for satisfactory operation of the whole system	Item3	1	Set		-	-	-	-	-	-	0.00		-	0.00	0.00
<b>Total in Figures</b>															<b>0.00</b>	<b>0.00</b>
<b>Quoted Rate in Words</b>															<b>INR Zero Only</b>	

Tender Inviting Authority: (AAPC) ALIMCO Bhubaneswar (ANNAXURE C2)

Name of Work: Regarding Supply, Installation & Commissioning of CNC Laser Tube Cutting System on Turnkey Basis

Contract No: PT/OT/05/AY

Enter GSTIN No	
Name of the Bidder/ Bidding Firm / Company :	

**PRICE SCHEDULE**

(This BOQ template must not be modified/replaced by the bidder and the same should be uploaded after filling the relevant columns, else the bidder is liable to be rejected for this tender. Bidders are allowed to enter the Bidder Name and Values only )

**Note:**

A) The basic Price/rate, Taxes, Packing & Forwarding charges and Freight charges must be mentioned separately & Specifically. The offer quoted inclusive of Taxes, Packing & Forwarding charges and freight charges will summarily be rejected. The same is essential keeping in view the applicability of GST proposed to be implemented w.e.f. 01.07.2017 by the Government. The impact (%age) of GST on item,/items will be admissible as applicable on the basic rate being statutory levy only during currency of Purchase Order/Contract against party's request alongwith necessary documents in support of their claim/amendments.

B) Giving HSN code, GSTIN & GST is mandatory and the bills after placement of order should mention the same HSN code, GSTIN & GST. Providing correct HSN code, GSTIN & GST is the responsibility of the vendor and ALIMCO is no way responsible for any subsequent interpretation/ order by the tax authorities.

NUMBER #	TEXT #	TEXT #	NUMBER #	TEXT #	NUMBER	NUMBER #	NUMBER	NUMBER	NUMBER	NUMBER	TEXT	TEXT	NUMBER	NUMBER	NUMBER #	NUMBER #
Sl. No.	Item Description	Item Code / Make	Quantity	Units	HSN Code/ SAC Code	BASIC RATE Per Unit In Rs (B)	Total Basic Cost (TBC) in Rs (B)	Freight Charges (FC) on TBC in (%) (C)	Freight Charges (Rs) (C)	Packing & Forwading Charges (PnF) on TBC in (%) (D)	Packing & Forwading Charges (Rs) (D)	Sub Total (TBC+ FC+PnF) in Rs. (E)	GST on Sub Total(E) in (%) (F)	GST in Rs. (F)	TOTAL AMOUNT Without Taxes (Sub Total) Rs. P	TOTAL AMOUNT With Taxes in Rs. P
1	2	3	4	5	6	7	8	9	10	11	12	13	14	15	16	16
1.01	Regarding Supply of CNC Laser Tube Cutting System on (Turnkey Basis) as per the details enclosed at Annexure-A	Item1	1	Set		-	-	-	-	-	-	0.00		-	0.00	0.00
1.02	Installation & Commissioning Charges including Civil, Electrical work on turnkey basis for satisfactory commissioning of the machine/equipment (if any)	Item2	1	Set		-	-	-	-	-	-	0.00		-	0.00	0.00
1.03	Supply of any other additional items (other than specified at Annexure-A) which are necessarily required for satisfactory operation of the whole system	Item3	1	Set		-	-	-	-	-	-	0.00		-	0.00	0.00
<b>Total in Figures</b>															<b>0.00</b>	<b>0.00</b>
<b>Quoted Rate in Words</b>															<b>INR Zero Only</b>	

Tender Inviting Authority: (AAPC) ALIMCO Jabalpur (ANNAXURE C3)

Name of Work: Regarding Supply, Installation & Commissioning of CNC Laser Tube Cutting System on Turnkey Basis

Contract No: PT/OT/05/AY

Enter GSTIN No	
Name of the Bidder/ Bidding Firm / Company :	

**PRICE SCHEDULE**

(This BOQ template must not be modified/replaced by the bidder and the same should be uploaded after filling the relevant columns, else the bidder is liable to be rejected for this tender. Bidders are allowed to enter the Bidder Name and Values only )

**Note:**

A) The basic Price/rate, Taxes, Packing & Forwarding charges and Freight charges must be mentioned separately & Specifically. The offer quoted inclusive of Taxes, Packing & Forwarding charges and freight charges will summarily be rejected. The same is essential keeping in view the applicability of GST proposed to be implemented w.e.f. 01.07.2017 by the Government. The impact (%age) of GST on item,/items will be admissible as applicable on the basic rate being statutory levy only during currency of Purchase Order/Contract against party's request alongwith necessary documents in support of their claim/amendments.

B) Giving HSN code, GSTIN & GST is mandatory and the bills after placement of order should mention the same HSN code, GSTIN & GST. Providing correct HSN code, GSTIN & GST is the responsibility of the vendor and ALIMCO is no way responsible for any subsequent interpretation/ order by the tax authorities.

NUMBER #	TEXT #	TEXT #	NUMBER #	TEXT #	NUMBER	NUMBER #	NUMBER	NUMBER	NUMBER	NUMBER	TEXT	TEXT	NUMBER	NUMBER	NUMBER #	NUMBER #
Sl. No.	Item Description	Item Code / Make	Quantity	Units	HSN Code/ SAC Code	BASIC RATE Per Unit In Rs (B)	Total Basic Cost (TBC) in Rs (B)	Freight Charges (FC) on TBC in (%)	Freight Charges (Rs) (C)	Packing & Forwading Charges (PnF) on TBC in (%)	Packing & Forwading Charges (Rs) (D)	Sub Total (TBC+ FC+PnF) in Rs. (E)	GST on Sub Total(E) in (%)	GST in Rs. (F)	TOTAL AMOUNT Without Taxes (Sub Total) Rs. P	TOTAL AMOUNT With Taxes in Rs. P
1	2	3	4	5	6	7	8	9	10	11	12	13	14	15	16	
1.01	Regarding Supply of CNC Laser Tube Cutting System on (Turnkey Basis) as per the details enclosed at Annexure-A	Item1	1	Set		-	-	-	-	-	-	0.00		-	0.00	0.00
1.02	Installation & Commissioning Charges including Civil, Electrical work on turnkey basis for satisfactory commissioning of the machine/equipment (if any)	Item2	1	Set		-	-	-	-	-	-	0.00		-	0.00	0.00
1.03	Supply of any other additional items (other than specified at Annexure-A) which are necessarily required for satisfactory operation of the whole system	Item3	1	Set		-	-	-	-	-	-	0.00		-	0.00	0.00
<b>Total in Figures</b>															<b>0.00</b>	<b>0.00</b>
<b>Quoted Rate in Words</b>															<b>INR Zero Only</b>	

Tender Inviting Authority: (AAPC) ALIMCO Chanalon (ANNAXURE C4)

Name of Work: Regarding Supply, Installation & Commissioning of CNC Laser Tube Cutting System on Turnkey Basis

Contract No: PT/OT/05/AY

Enter GSTIN No	
Name of the Bidder/ Bidding Firm / Company :	

**PRICE SCHEDULE**

(This BOQ template must not be modified/replaced by the bidder and the same should be uploaded after filling the relevant columns, else the bidder is liable to be rejected for this tender. Bidders are allowed to enter the Bidder Name and Values only )

**Note:**

A) The basic Price/rate, Taxes, Packing & Forwarding charges and Freight charges must be mentioned separately & Specifically. The offer quoted inclusive of Taxes, Packing & Forwarding charges and freight charges will summarily be rejected. The same is essential keeping in view the applicability of GST proposed to be implemented w.e.f. 01.07.2017 by the Government. The impact (%age) of GST on item,/items will be admissible as applicable on the basic rate being statutory levy only during currency of Purchase Order/Contract against party's request alongwith necessary documents in support of their claim/amendments.

B) Giving HSN code, GSTIN & GST is mandatory and the bills after placement of order should mention the same HSN code, GSTIN & GST. Providing correct HSN code, GSTIN & GST is the responsibility of the vendor and ALIMCO is no way responsible for any subsequent interpretation/ order by the tax authorities.

NUMBER #	TEXT #	TEXT #	NUMBER #	TEXT #	NUMBER	NUMBER #	NUMBER	NUMBER	NUMBER	NUMBER	TEXT	TEXT	NUMBER	NUMBER	NUMBER #	NUMBER #
Sl. No.	Item Description	Item Code / Make	Quantity	Units	HSN Code/ SAC Code	BASIC RATE Per Unit In Rs (B)	Total Basic Cost (TBC) in Rs (B)	Freight Charges (FC) on TBC in (%) (C)	Freight Charges (Rs) (C)	Packing & Forwading Charges (PnF) on TBC in (%) (D)	Packing & Forwading Charges (Rs) (D)	Sub Total (TBC+ FC+PnF) in Rs. (E)	GST on Sub Total(E) in (%) (F)	GST in Rs. (F)	TOTAL AMOUNT Without Taxes (Sub Total) Rs. P (F)	TOTAL AMOUNT With Taxes in Rs. P (F)
1	2	3	4	5	6	7	8	9	10	11	12	13	14	15	16	
1.01	Regarding Supply of CNC Laser Tube Cutting System on (Turnkey Basis) as per the details enclosed at Annexure-A	Item1	1	Set			-		-		-	0.00		-	0.00	0.00
1.02	Installation & Commissioning Charges including Civil, Electrical work on turnkey basis for satisfactory commissioning of the machine/equipment (if any)	Item2	1	Set			-		-		-	0.00		-	0.00	0.00
1.03	Supply of any other additional items (other than specified at Annexure-A) which are necessarily required for satisfactory operation of the whole system	Item3	1	Set			-		-		-	0.00		-	0.00	0.00
<b>Total in Figures</b>															<b>0.00</b>	<b>0.00</b>
<b>Quoted Rate in Words</b>															<b>INR Zero Only</b>	

Tender Inviting Authority: (AAPC) ALIMCO Ujjain (ANNAXURE C5)

Name of Work: Regarding Supply, Installation & Commissioning of CNC Laser Tube Cutting System on Turnkey Basis

Contract No: PT/OT/05/AY

Enter GSTIN No	
Name of the Bidder/ Bidding Firm / Company :	

**PRICE SCHEDULE**

(This BOQ template must not be modified/replaced by the bidder and the same should be uploaded after filling the relevant columns, else the bidder is liable to be rejected for this tender. Bidders are allowed to enter the Bidder Name and Values only )

**Note:**

A) The basic Price/rate, Taxes, Packing & Forwarding charges and Freight charges must be mentioned separately & Specifically. The offer quoted inclusive of Taxes, Packing & Forwarding charges and freight charges will summarily be rejected. The same is essential keeping in view the applicability of GST proposed to be implemented w.e.f. 01.07.2017 by the Government. The impact (%age) of GST on item,/items will be admissible as applicable on the basic rate being statutory levy only during currency of Purchase Order/Contract against party's request alongwith necessary documents in support of their claim/amendments.

B) Giving HSN code, GSTIN & GST is mandatory and the bills after placement of order should mention the same HSN code, GSTIN & GST. Providing correct HSN code, GSTIN & GST is the responsibility of the vendor and ALIMCO is no way responsible for any subsequent interpretation/ order by the tax authorities.

NUMBER #	TEXT #	TEXT #	NUMBER #	TEXT #	NUMBER	NUMBER #	NUMBER	NUMBER	NUMBER	NUMBER	TEXT	TEXT	NUMBER	NUMBER	NUMBER #	NUMBER #
Sl. No.	Item Description	Item Code / Make	Quantity	Units	HSN Code/ SAC Code	BASIC RATE Per Unit In Rs (B)	Total Basic Cost (TBC) in Rs (B)	Freight Charges (FC) on TBC in (%) (C)	Freight Charges (Rs) (C)	Packing & Forwading Charges (PnF) on TBC in (%) (D)	Packing & Forwading Charges (Rs) (D)	Sub Total (TBC+ FC+PnF) in Rs. (E)	GST on Sub Total(E) in (%) (F)	GST in Rs. (F)	TOTAL AMOUNT Without Taxes (Sub Total) Rs. P	TOTAL AMOUNT With Taxes in Rs. P
1	2	3	4	5	6	7	8	9	10	11	12	13	14	15	16	16
1.01	Regarding Supply of CNC Laser Tube Cutting System on (Turnkey Basis) as per the details enclosed at Annexure-A	Item1	1	Set		-	-	-	-	-	-	0.00		-	0.00	0.00
1.02	Installation & Commissioning Charges including Civil, Electrical work on turnkey basis for satisfactory commissioning of the machine/equipment (if any)	Item2	1	Set		-	-	-	-	-	-	0.00		-	0.00	0.00
1.03	Supply of any other additional items (other than specified at Annexure-A) which are necessarily required for satisfactory operation of the whole system	Item3	1	Set		-	-	-	-	-	-	0.00		-	0.00	0.00
<b>Total in Figures</b>															<b>0.00</b>	<b>0.00</b>
<b>Quoted Rate in Words</b>															<b>INR Zero Only</b>	

Tender Inviting Authority: **AAPC BANGALORE (ANNAXURE C6)**

Name of Work: **Regarding Supply, Installation & Commissioning of CNC Laser Tube Cutting System on Turnkey Basis**

Contract No: **PT/OT/05/AY**

Enter GSTIN No	
Name of the Bidder/ Bidding Firm / Company :	

**PRICE SCHEDULE**

(This BOQ template must not be modified/replaced by the bidder and the same should be uploaded after filling the relevant columns, else the bidder is liable to be rejected for this tender. Bidders are allowed to enter the Bidder Name and Values only )

**Note:**

A) The basic Price/rate, Taxes, Packing & Forwarding charges and Freight charges must be mentioned separately & Specifically. The offer quoted inclusive of Taxes, Packing & Forwarding charges and freight charges will summarily be rejected. The same is essential keeping in view the applicability of GST proposed to be implemented w.e.f. 01.07.2017 by the Government. The impact (%age) of GST on item,/items will be admissible as applicable on the basic rate being statutory levy only during currency of Purchase Order/Contract against party's request alongwith necessary documents in support of their claim/amendments.

B) Giving HSN code, GSTIN & GST is mandatory and the bills after placement of order should mention the same HSN code, GSTIN & GST. Providing correct HSN code, GSTIN & GST is the responsibility of the vendor and ALIMCO is no way responsible for any subsequent interpretation/ order by the tax authorities.

NUMBER #	TEXT #	TEXT #	NUMBER #	TEXT #	NUMBER	NUMBER #	NUMBER	NUMBER	NUMBER	NUMBER	TEXT	TEXT	NUMBER	NUMBER	NUMBER #	NUMBER #
Sl. No.	Item Description	Item Code / Make	Quantity	Units	HSN Code/ SAC Code	BASIC RATE Per Unit In Rs (B)	Total Basic Cost (TBC) in Rs (B)	Freight Charges (FC) on TBC in (%) (C)	Freight Charges (Rs) (C)	Packing & Forwading Charges (PnF) on TBC in (%) (D)	Packing & Forwading Charges (Rs) (D)	Sub Total (TBC+ FC+PnF) in Rs. (E)	GST on Sub Total(E) in (%) (F)	GST in Rs. (F)	TOTAL AMOUNT Without Taxes (Sub Total) Rs. P (F)	TOTAL AMOUNT With Taxes in Rs. P (F)
1	2	3	4	5	6	7	8	9	10	11	12	13	14	15	16	16
1.01	Regarding Supply of CNC Laser Tube Cutting System on (Turnkey Basis) as per the details enclosed at Annexure-A	Item1	1	Set		-	-	-	-	-	-	0.00		-	0.00	0.00
1.02	Installation & Commissioning Charges including Civil, Electrical work on turnkey basis for satisfactory commissioning of the machine/equipment (if any)	Item2	1	Set		-	-	-	-	-	-	0.00		-	0.00	0.00
1.03	Supply of any other additional items (other than specified at Annexure-A) which are necessarily required for satisfactory operation of the whole system	Item3	1	Set		-	-	-	-	-	-	0.00		-	0.00	0.00
<b>Total in Figures</b>															<b>0.00</b>	<b>0.00</b>
<b>Quoted Rate in Words</b>															<b>INR Zero Only</b>	

**SPECIFIC CONDITIONS OF SUPPLY:**

The tenderer should clearly indicate the following in their offer:

- 1) Installation/Commissioning – details,
- 2) Whether DGS & D/GEM/ or any other State/Central Rate Contract exists for the item offered. Please enclose copy.
- 3) Tenders are required to provide address, e-mail, contact person of local service centre/Nearest Service centre from where service support shall be provided.
- 4) Any other relevant technical details of the offered Machine/item/equipment& its accessories.
- 5) Complete details of infrastructural requirement for the offered Machine/item/equipment& its accessories i.e.  
Ambient working atmosphere requirement  
Power connections requirement.
- 6) Tenderer is required to provide a list of parties with their complete postal address with telephone / e-mail. To whom they have supplied similar Machine/item/equipment over the last 5-8 years. The list should clearly indicate the quantity and the model of the Machine/item/equipment supplied to such customers.
- 7) Tenderer is required to give complete details of the training facilities, if available, with their organization for training our technicians and engineers on the use and maintenance of the Machine/item/equipment& its accessories. Details of complimentary training should also be indicated in the offer.
- 8) Tenderer is required to clearly indicate the details of infrastructure of after sales service facility with its location together with the anticipated time of attending complaints after their receipt of complaint in their service center.
- 09) Tenderer should clearly indicate the reasons as to why they consider their Machine/item/equipment and their offer to be best for supply to the Corporation. The tenderer should enclose all documentary evidence in support of their claim along with their offer.
- 10) The equipments would be required to be supplied and installed in the company premises as specified in Para 1 of the tender document. As such the tenderers should clearly confirm their acceptance to deliver / install and provide after sales service during the warranty period and afterwards at Corporation premises or as the location as specified in the tender document. They are also required to indicate the nearest service point location with address for providing services in respect of the offered Machine/item/equipment.
- 11) In case the tenderer desires to provide supplies of add on optional accessories for the effective functioning of the system on complimentary / chargeable basis, he should clearly indicate items along with the terms of supply. The value of the complimentary supplies proposed should be clearly indicated in the offer.
- 12) The tenderer should **necessarily enclose the complete exhaustive literature / Printed catalogue of their offered Machine/item/equipment& its Accessories** indicating full technical details/specifications and special features of their machine/equipment together with their make & model, etc.
- 13) In case of existence of a **DGS & D/GEM/GEM rate contract or a State/Central Govt. Rate Contract** in respect of the supply of the offered machine/equipment, an authenticated copy of the same should also be enclosed along with the offer. The enclosing of a copy of the relevant rate contract would still permit the tenderer to submit a lower competitive offer in which case the corporation would consider only the lower offer for comparison and analysis.

- 14) The tenderers are required to submit exhaustive (anticipated) list of spares likely to be used on chargeable basis during the period of 03 years together with their prices indicating validity period of each spares for our necessary reference and records.
- 15) In case of any problem / trouble / defect after commissioning the local service provider is required to respond / attend the problem within 48 Hrs.
- 16) The repeat orders may be placed up to 100% of quantity of original order where the original order was placed on the supplier selected on the basis of ST/OT/LT/ team purchase only for ordering additional quantity. The repeat order will be placed on same rates and terms as mentioned in initial order.

\*\*\*\*\*



**FORMAT FOR BANK GUARANTEE TOWARDS SECURITY DEPOSIT/PERFORMANCE GUARANTEE**

(To be executed by any Nationalised Bank in India, on a Rs. 200 non-judicial stamp paper under bank's covering letter mentioning address of the bank)

In consideration of M/s Artificial Limbs Manufacturing Corporation of India, hereinafter referred to as 'ALIMCO', which expression unless repugnant to the context and meaning thereof shall include its successors and assigns having agreed to exempt M/s \_\_\_\_\_ (Name of the vender/supplier/contractor) hereinafter referred to as supplier/contractor which expression unless repugnant to the context and meaning thereof shall include its successors and assigns] from depositing with ALIMCO a sum of Rs. \_\_\_\_\_ towards security / performance guarantee in lieu of the said supplier/contractor having agreed to furnish a bank guarantee for the said sum of Rs. \_\_\_\_\_ as required under the terms and conditions of contract / work order / purchase order no. \_\_\_\_\_ dated \_\_\_\_\_ [hereinafter referred as the order'] placed by ALIMCO on the said supplier / contractor.

We, \_\_\_\_\_ the bank [hereinafter referred to as 'the bank' which expression shall include Its successors and assigns] do hereby undertake to pay ALIMCO an amount not exceeding Rs. \_\_\_\_\_ on the demand made by ALIMCO on us due to a breach committed by the said supplier / contractor of the terms and conditions of the order.

We \_\_\_\_\_ the bank hereby undertakes to pay the amount under the guarantee without any demur merely on a demand from ALIMCO stating that there is a breach by the supplier / contractor of any of the terms and conditions contained in the order or by the reasons of the supplier's / contractor's failure to comply with the terms and conditions as stipulated in the order or amendment(s) thereto.

The demand made on the bank shall be conclusive as to the breach of the terms and conditions of the order and as regard to the amount due and payable by the bank under this guarantee, notwithstanding any dispute or disputes raised by the said supplier / contractor regarding the validity of such breach and we agree to pay the amount so demanded by ALIMCO without any demur. However, our liability under this guarantee shall be restricted to an amount not exceeding Rs. \_\_\_\_\_.

We, \_\_\_\_\_ the bank further agree that the guarantee herein contained shall remain in full force and effect during the period that would be taken for the performance of the said order and that it shall continue to be enforceable till the dues of ALIMCO under or by virtue of the said order have been fully paid and its claim satisfied or discharged or till ALIMCO certifies that the terms and conditions of the order have been fully and properly carried out by the supplier / contractor and accordingly discharge the guarantee.

We \_\_\_\_\_ the bank, undertake to pay to ALIMCO any money so demanded notwithstanding any dispute or disputes raised by the said supplier / contractor in any suit or proceedings pending before any court or tribunal relating thereto as our liability under this present being absolute and unequivocal. The payment so made by us under this bond shall be valid discharge of our liability for payment there under and the said supplier / contractor shall have no claim against us for making such payment.

We \_\_\_\_\_ the bank further agree that ALIMCO shall have full liberty, without our consent and without affecting in any manner our obligation hereunder to vary any of the terms and conditions of the order or to extend time of performance by the said supplier / contractor from time to time or to postpone for any time or from time to time any of the powers exercisable by the ALIMCO against the said supplier / contractor and to forbear or enforce any of the terms and conditions relating to the order and shall not be relieved from our liability by reason of any such variation or extension being granted to the said supplier / contractor or for any forbearance, act or omission on the part of ALIMCO or any indulgence by ALIMCO to the supplier / contractor or by any such matter or thing whatsoever which under the law relating to sureties would but for this provisions have effect of so relieving us. Our liability under this guarantee is restricted to Rs. \_\_\_\_\_ and shall remain in force up to \_\_\_\_\_ unless demand or claim under this guarantee is made on us in writing within 3 months from the date of expiry viz. \_\_\_\_\_. We shall be discharged from all liabilities under this guarantee thereafter.

This guarantee will not discharge due to change in the constitution in the bank or the said supplier / contractor.

The bank hereby agrees to address all the future correspondence in regard to this bank guarantee to Chairman & Managing Director, Artificial Limbs Manufacturing Corporation of India.

We, \_\_\_\_\_ the bank lastly undertake not to revoke this guarantee during its currency except with the previous consent of ALIMCO in writing.

Signed on the \_\_\_\_\_ day of

**Witness**

**Signature  
For the Bank**

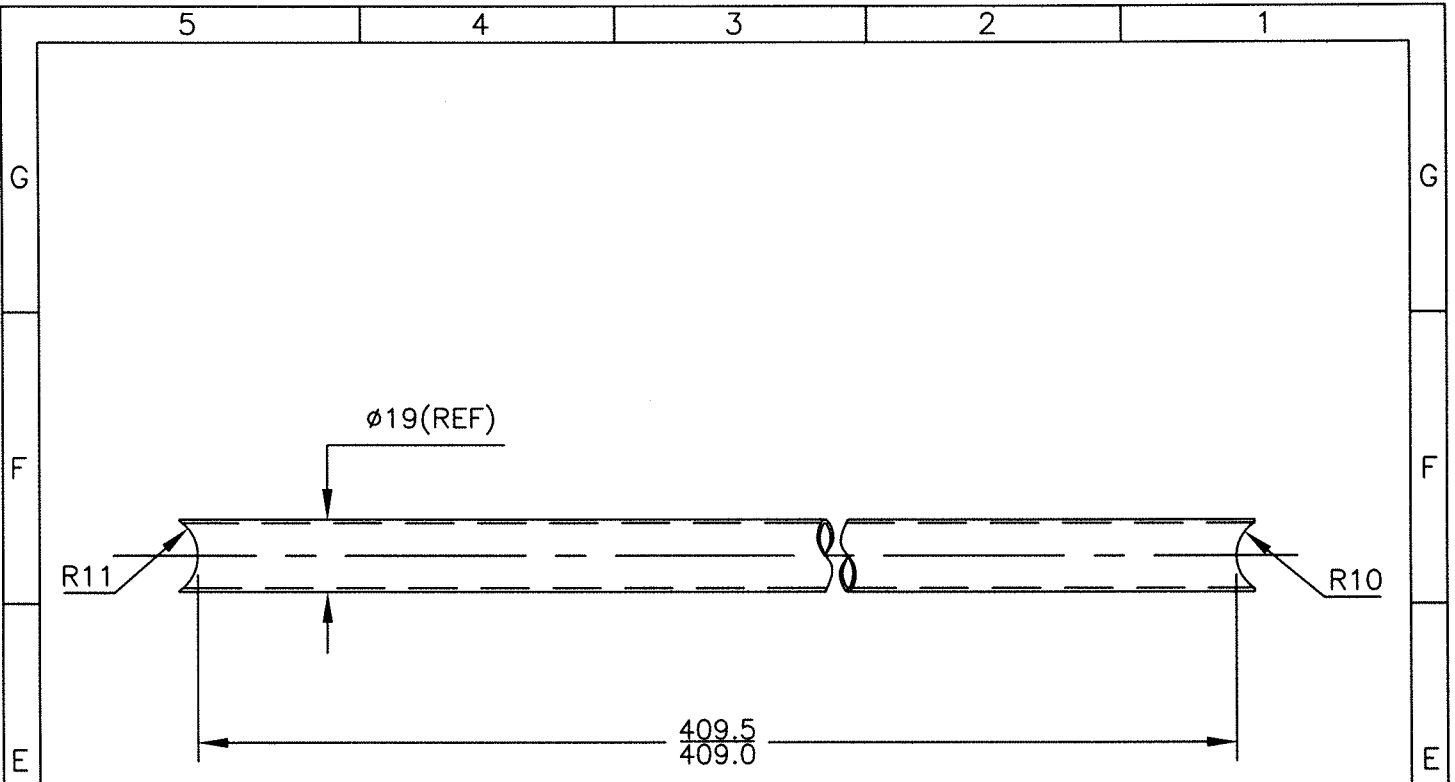



MTL:--

STEEL TUBE CEW OD 19.05±0.1  
 ID 17.25±0.08,BS:1717(AF02)  
 OR  
 STEEL TUBE ERW-C1 OD19.05mm  
 THICK1.0mm,IS2039ANNEALED (AF14)

NOTE:--

1.REMOVE SHARP EDGES & CORNERS.

5.	_____	DRAWING REDRAWN	03.12.14	<i>[Signature]</i>
SNo.	REGION	REVISION	DATE	SIGN
R E V I S I O N S				
		ARTIFICIAL LIMBS MANUFACTURING CORPORATION OF INDIA KANPUR		
				
DGN		NOM	TUBE UPPER	
DRN	<i>Ashish</i>	MTL	INDICATED	
CHD	<i>[Signature]</i>	TOL	INTEGER ONLY ±0.500 mm	UNLESS SPECIFIED
DIM	1N mm		ONE PLACE DECIMAL ±0.250 mm	
			TWO PLACE DECIMAL ±0.126 mm	
SCALE	NTS	FIN		
01	K	5	162	
APP	<i>SA/DD1</i>	DRG No:-- TD 2 C 51 A 03		SHEET 10F1
DATE	25.09.1992			

5

4

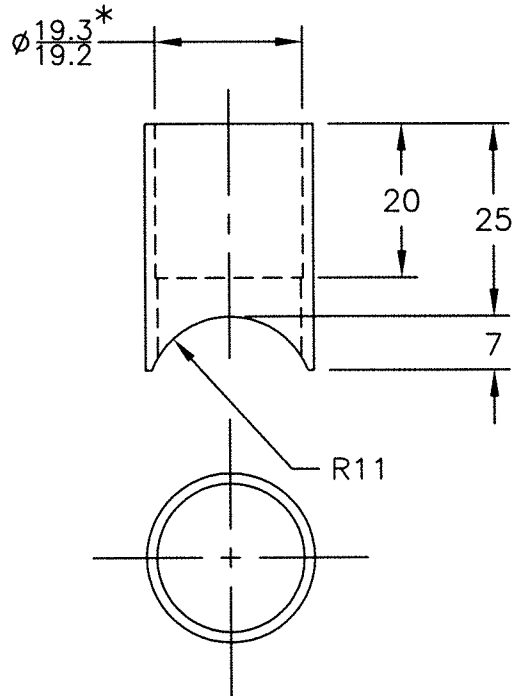

NOTE:--

- 1.\*BORE/REAM IF TUBE FRONT (TD 2 A 07 A 02) IS NOT TELESCOPIC WITH NOMINAL DIMENSIONS.
2. REMOVE SHARP EDGES & CORNERS.

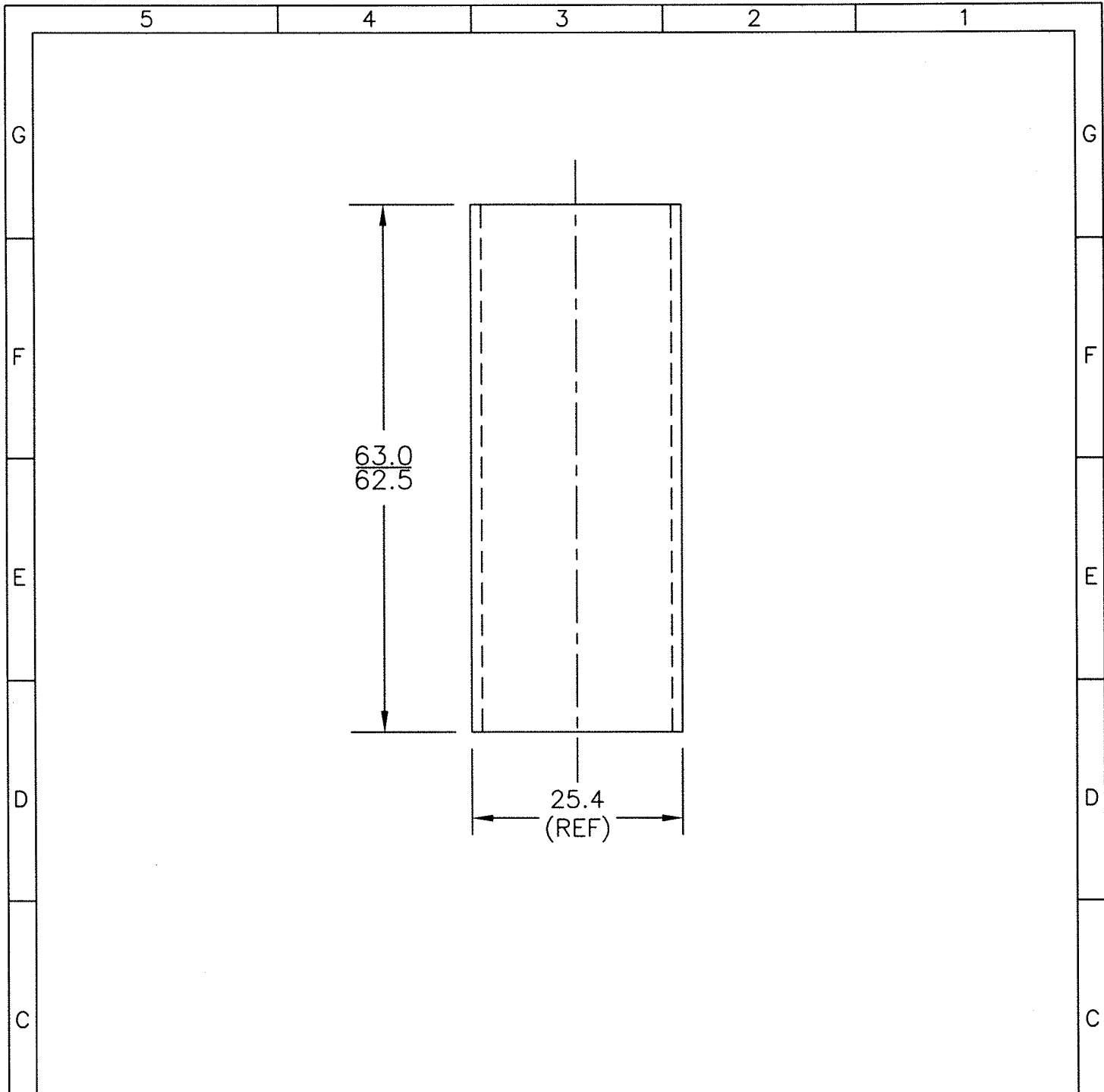

4.	---	DRAWING REDRAWN	14.01.15	<i>Das</i>
SN0.	REGION	REVISION	DATE	SIGN
R E V I S I O N S				
		ARTIFICIAL LIMBS MANUFACTURING CORPORATION OF INDIA KANPUR		
DGN		NOM	EXTENSION FRONT	
DRN	<i>Ashish</i>	MTL	STEEL TUBE ERW-C1 OD 22.23mm THK 1.6mm IS:2039 ANNEALED(AF13)	
CHD	<i>Das</i>	TOL	INTEGER ONLY $\pm 0.500$ mm ONE PLACE DECIMAL $\pm 0.250$ mm TWO PLACE DECIMAL $\pm 0.126$ mm UNLESS SPECIFIED	
DIM	IN mm	FIN	---	
SCALE	NTS			
APP	<i>Sa/DD1</i>	DRG No:--TD 2 A 07 A 01		SHEET 10F1
DATE	26.05.1978			

01	K	5	012
5		4	



NOTE:---

1. REMOVE SHARP EDGES & CORNERS.

8.	---	DRAWING REDRAWN	14.01.15	<i>Raw</i>
SNo.	REGION	REVISION	DATE	SIGN
R E V I S I O N S				
		ARTIFICIAL LIMBS MANUFACTURING CORPORATION OF INDIA KANPUR		
				
DGN		NOM	TUBE ADAPTER FRONT WHEEL	
DRN	<i>Ashish</i>	MTL	STEEL TUBE ERW C1 OD 25.4mm THICK 1.25mm IS:2039 ANNEALED (AF 60)	
CHD	<i>Raw</i>			
DIM	IN mm	TOL	INTEGER ONLY ±0.500 mm ONE PLACE DECIMAL ±0.250 mm TWO PLACE DECIMAL ±0.126 mm	UNLESS SPECIFIED
SCALE	NTS	FIN	---	
01	K	8	085	
5	4	DATE	16.01.1982	DRG No: -TD 2 A 07 A 22
				SHEET 10F1

5

4

3

2

1

G

G

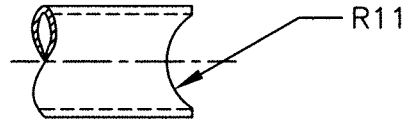

VIEW IN DIRECTION 'A'

F

F

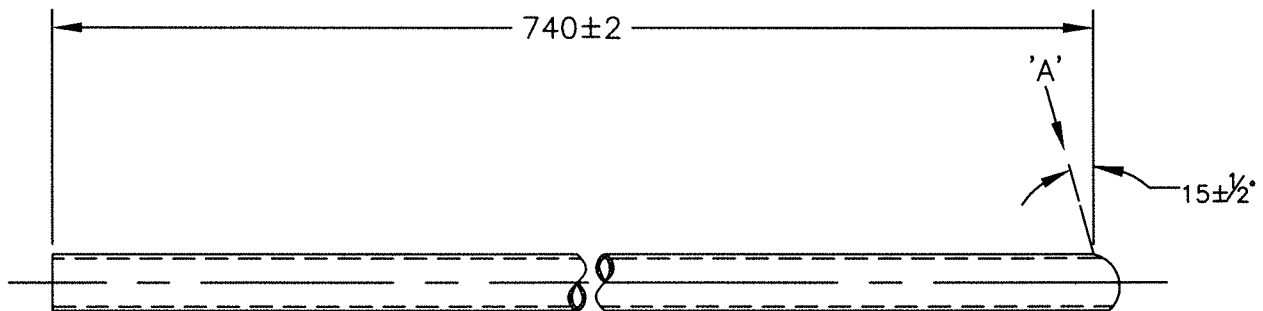

E

E

D

D

C

C

NOTE:---

1. REMOVE SHARP EDGES &amp; CORNERS.

B

B

A

A

8.	—	DRAWING REDRAWN	14.01.15	<i>Gray</i>
SNo.	REGION	REVISION	DATE	SIGN

## R E V I S I O N S



ARTIFICIAL LIMBS  
MANUFACTURING CORPORATION  
OF INDIA  
KANPUR



DGN		NOM	TUBE LOWER	
DRN	<i>Ashish</i>	MTL	STEEL TUBE ERW-C1 OD 22.23mm THK 1.6mm IS:2039 ANNEALED(AF13)	
CHD	<i>Gray</i>	TOL	INTEGER ONLY ±0.500 mm ONE PLACE DECIMAL ±0.250 mm TWO PLACE DECIMAL ±0.126 mm	UNLESS SPECIFIED
DIM	IN mm	FIN	—	
SCALE	NTS			
APP	<i>Sd/DD I</i>	DRG No:--TD 2 A 02 A 14		SHEET 10F1
DATE	30.12.1982			

01

K

5

165

5

4

5 4 3 2 1

G

G

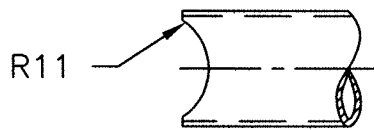

VIEW IN DIRECTION 'Y'

F

F

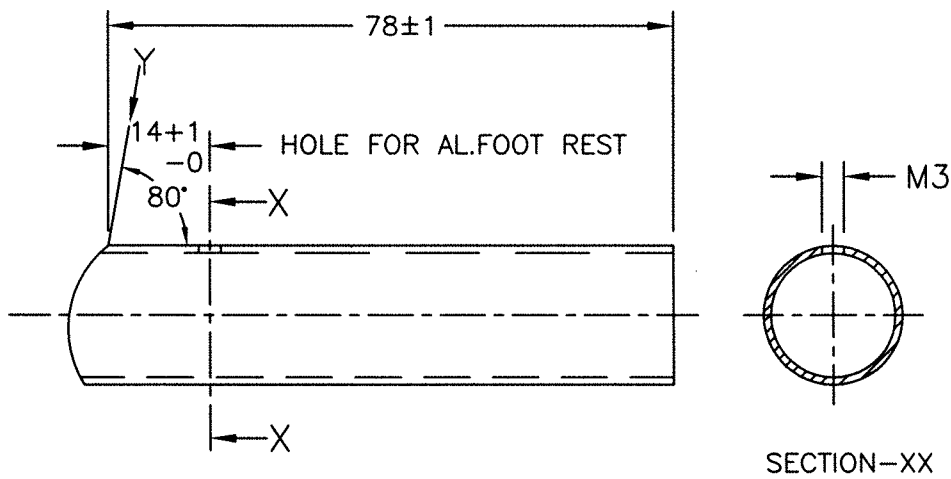

E

E

D

D

C

C

NOTE:---

1.REMOVE SHARP EDGES & CORNERS.

13.	---	DRAWING REDRAWN	12.02.15	<i>Raw</i>
SNo.	REGION	REVISION	DATE	SIGN

REVISIONS



ARTIFICIAL LIMBS  
MANUFACTURING CORPORATION  
OF INDIA  
KANPUR



B

B

A

A

DGN	<i>Ashish</i>	NOM	TUBE FOOT REST	
DRN	<i>Raw</i>	MTL	STEEL TUBE ERW C-1,0D 19.05 THICK 1.0mm IS:2039 ANNEALED (AF14)	
CHD	<i>Raw</i>	TOL	INTEGER ONLY	±0.500 mm
DIM	IN mm		ONE PLACE DECIMAL	±0.250 mm
			TWO PLACE DECIMAL	±0.126 mm
SCALE	NTS	FIN	---	
APP	<i>Sol/DD1</i>	DRG No:--	TD 2 A 07 K 02	SHEET 10F1
DATE	09.05.1978			

01	K	5	057
5		4	

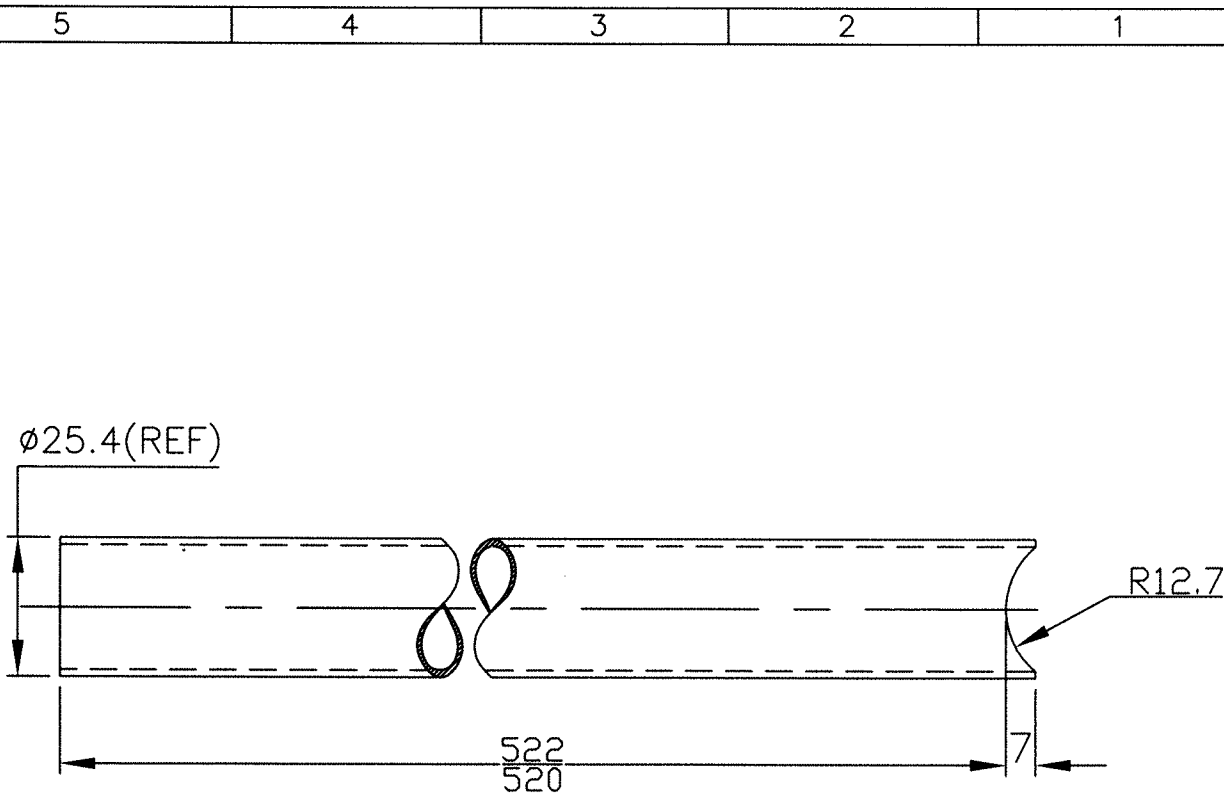

NOTE:-

1.REMOVE SHARP EDGES & CORNERS

5	—	DRAWING REDRAWN	7.5.13	<i>[Signature]</i>
SNo.	REGION	REVISION	DATE	SIGN
R E V I S I O N S				
		ARTIFICIAL LIMBS MANUFACTURING CORPORATION OF INDIA KANPUR		
DGN	<i>[Signature]</i>	NOM	VERTICAL SUPPORT	
DRN	<i>[Signature]</i>	MTL	STEEL TUBE ERW C1 OD25.4mm THICK1.25mm ANNEALED IS:2039(AF60)	
CHD	<i>[Signature]</i>	TOL	INTEGER ONLY ±0.500 mm ONE PLACE DECIMAL ±0.250 mm TWO PLACE DECIMAL ±0.126 mm UNLESS SPECIFIED	
DIM	IN mm	FIN	—	
SCALE	NTS		—	
APP	<i>[Signature]</i>	DRG No:-	TD 2 C 98 J 02	SHEET 10F1
DATE	02.03.1994			

01 J 03 002

5



4

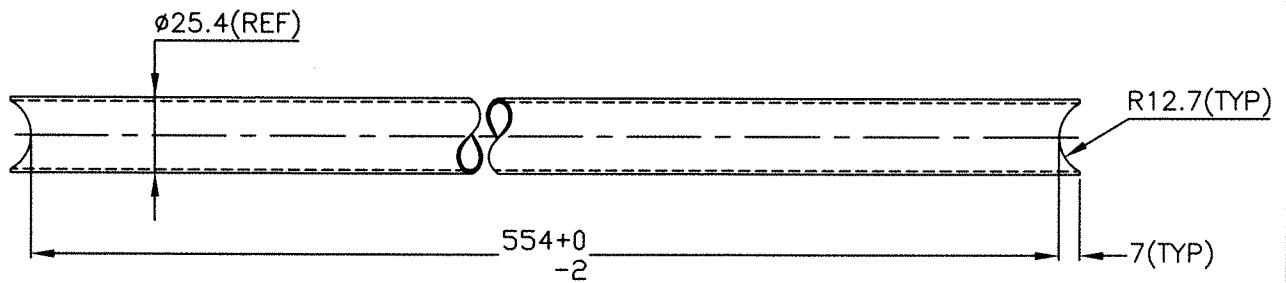



NOTE:—

1.REMOVE SHARP EDGES & CORNERS

7	—	DRAWING REDRAWN	7.5.13.1994
SNo.	REGION	REVISION	DATE SIGN
R E V I S I O N S			
		ARTIFICIAL LIMBS MANUFACTURING CORPORATION OF INDIA KANPUR	
			
DGN	<i>Chudh.</i>	NOM	REAR CROSS MEMBER
DRN	<i>Blaw</i>	MTL	STEEL TUBE ERW C1 OD25.4mm THICK1.25mm ANNEALED IS:2039(AF60)
CHD	<i>Blaw</i>	TOL	INTEGER ONLY ±0.500 mm ONE PLACE DECIMAL ±0.250 mm TWO PLACE DECIMAL ±0.126 mm UNLESS SPECIFIED
DIM	IN mm	FIN	
SCALE	NTS 		
APP	<i>Ed/SDI</i>	DRG No:—	TD 2 C 98 J 07
DATE	02.03.1994	SHEET	10F1

01 J 03 006

5

4

5 4 3 2 1

G G

F F

E E

D D

C C

B B

A A

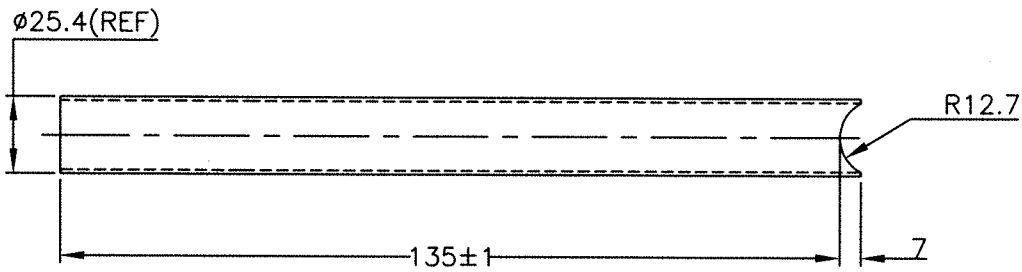

**NOTE:--**

1.REMOVE SHARP EDGES & CORNERS

4	—	DRAWING REDRAWN	7.5.13	12/07
SNo.	REGION	REVISION	DATE	SIGN

**R E V I S I O N S**



ARTIFICIAL LIMBS  
MANUFACTURING CORPORATION  
OF INDIA  
KANPUR



DGN	<i>Phal</i>	NOM	SEAT STIFFENER	
DRN	<i>Phal</i>	MTL	STEEL TUBE ERW C1 OD25.4mm, THICK1.25mm ANNEALED IS:2039(AF60)	
CHD	<i>Phal</i>	TOL	INTEGER ONLY	$\pm 0.500$ mm
DIM	IN mm		ONE PLACE DECIMAL	$\pm 0.250$ mm
			TWO PLACE DECIMAL	$\pm 0.126$ mm
SCALE	NTS	FIN	UNLESS SPECIFIED	
APP	<i>Sd</i>			
DATE	02.03.1994		DRG No:--TD 2 C 98 J 09	
			SHEET 10F1	

01 J 03 008

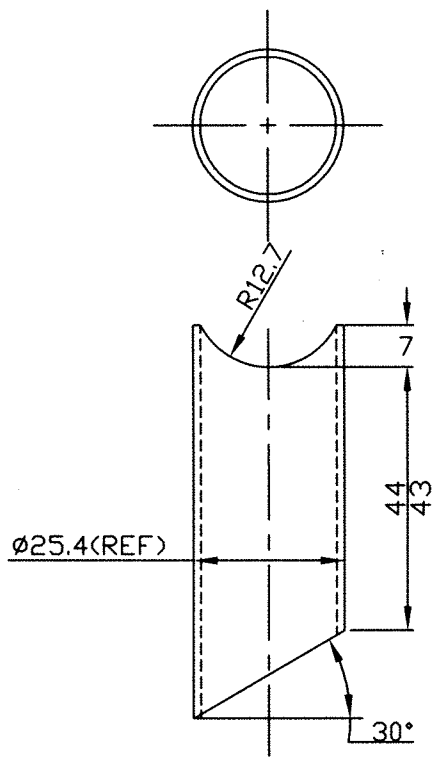

5

4



**NOTE:-**

1. REMOVE SHARP EDGES & CORNERS

4	—	DRAWING REDRAWN	7-5-13	<i>R210</i>
SNo.	REGION	REVISION	DATE	SIGN
R E V I S I O N S				
 ARTIFICIAL LIMBS MANUFACTURING CORPORATION OF INDIA KANPUR 				
DGN	<i>Ch.L.</i>	NOM	VERTICAL STIFFENER	
DRN	<i>Ch.L.</i>	MTL	STEEL TUBE ERW C1 OD25.4mm, THICK1.25mm ANNEALED IS:2039(AF60)	
CHD	<i>R210</i>	TOL	INTEGER ONLY ±0.500 mm ONE PLACE DECIMAL ±0.250 mm TWO PLACE DECIMAL ±0.126 mm	UNLESS SPECIFIED
DIM	IN mm	FIN		
SCALE	NTS			
APP	<i>sd 001</i>	DRG No:-TD 2 C 98 J 10		
DATE	02.03.1994	SHEET 10F1		

01 J 03 009

5

4

5 4 3 2 1

G  
F  
E  
D  
C  
B  
A

G  
F  
E  
D  
C  
B  
A

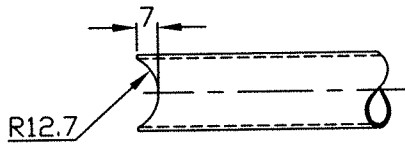

VIEW IN DIRECTION-'A'

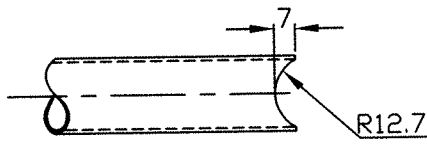
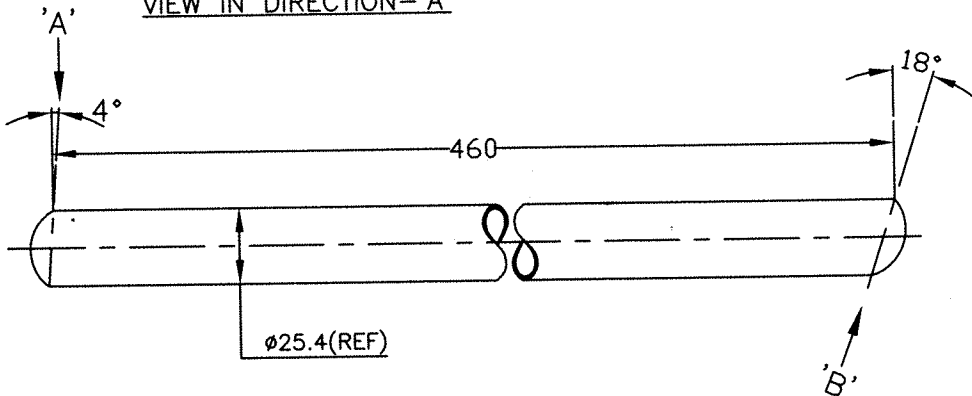

VIEW IN DIRECTION-'B'

**NOTE:-**

1.REMOVE SHARP EDGES & CORNERS

4	—	DRAWING REDRAWN	2.5.13	2105
SNo.	REGION	REVISION	DATE	SIGN

REVISIONS



ARTIFICIAL LIMBS  
MANUFACTURING CORPORATION  
OF INDIA  
KANPUR



DGN	<i>Phd</i>	NOM	SIDE FRAME SUPPORT TUBE	
DRN	<i>Phd</i>	MTL	STEEL TUBE ERW C1 OD25.4mm, THICK1.25mm ANNEALED IS:2039(AF60)	
CHD	<i>Phd</i>	TOL	INTEGER ONLY ±0.500 mm	UNLESS SPECIFIED
			ONE PLACE DECIMAL ±0.250 mm	
			TWO PLACE DECIMAL ±0.126 mm	
SCALE	NTS	FIN	—	

01 J 03 011

APP *Sl 001*  
DATE 02.03.1994

DRG No:-TD 2 C 98 J 12

SHEET 10F1

5

4

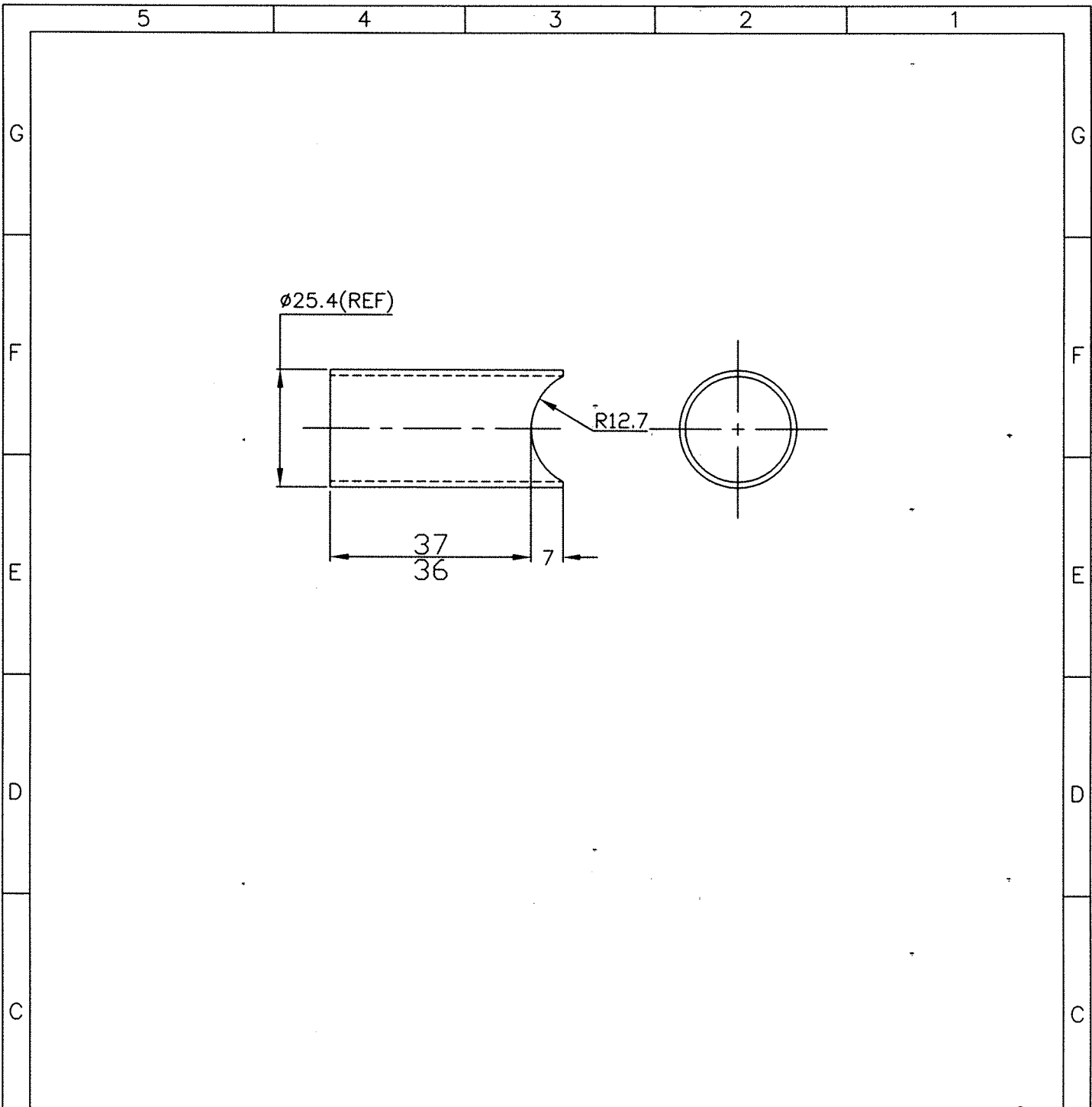

**NOTE:-**

1. REMOVE SHARP EDGES & CORNERS

5	—	DRAWING REDRAWN	7.5.13	<i>[Signature]</i>
SNo.	REGION	REVISION	DATE	SIGN
R E V I S I O N S				
		ARTIFICIAL LIMBS MANUFACTURING CORPORATION OF INDIA KANPUR		
DGN	<i>[Signature]</i>	NOM	STIFFENER	
DRN	<i>[Signature]</i>	MTL	STEEL TUBE ERW C1 OD25.4mm, THICK1.25mm ANNEALED IS:2039(AF60)	
CHD	<i>[Signature]</i>	TOL	INTEGER ONLY ±0.500 mm ONE PLACE DECIMAL ±0.250 mm TWO PLACE DECIMAL ±0.126 mm <small>UNLESS SPECIFIED</small>	
DIM	IN mm	FIN	—	
SCALE	NTS			
01	J	03	012	
5	4	DATE	02.03.1994	DRG No:-TD 2 C 98 J 13
				SHEET 10F1

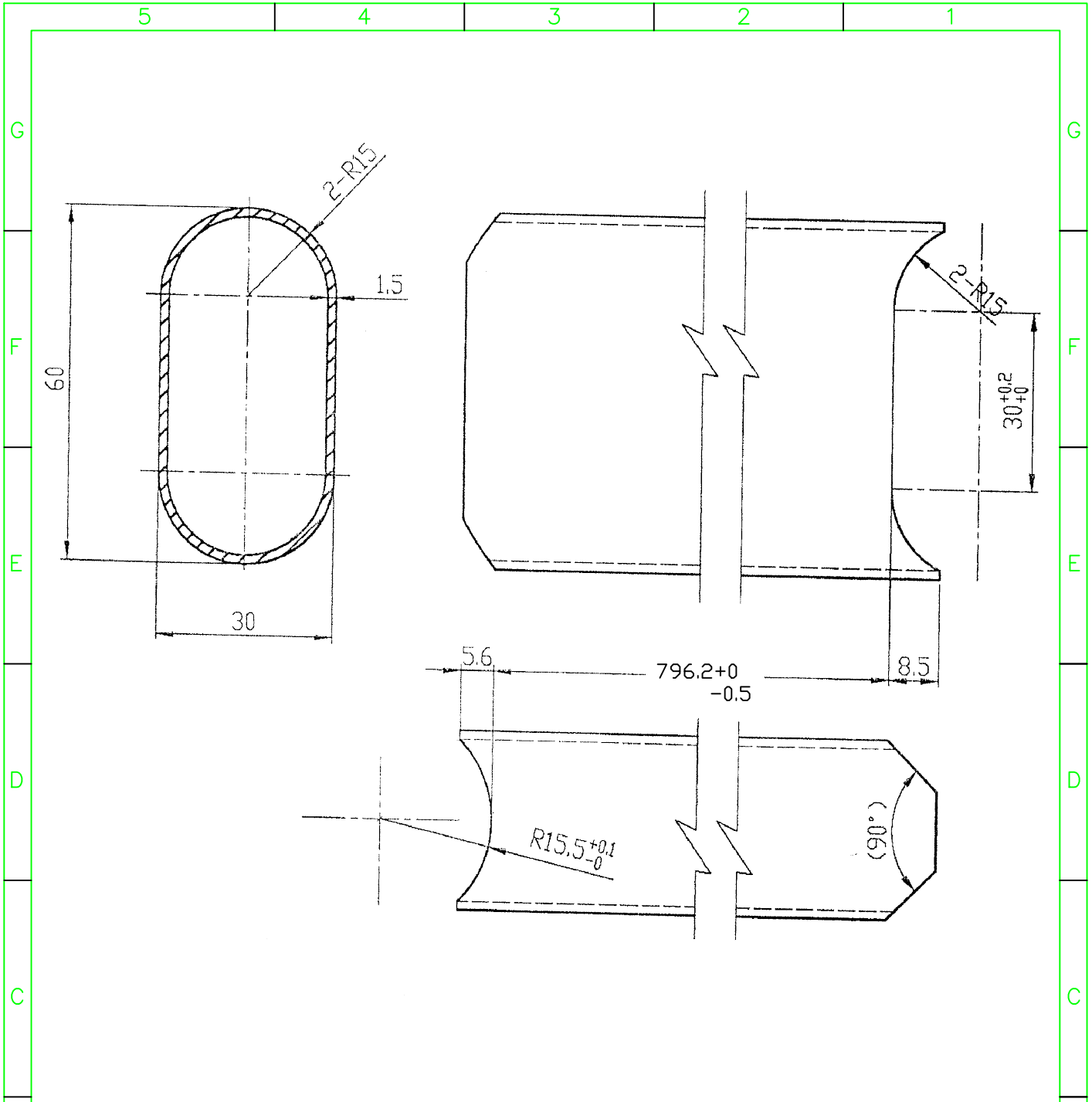

SNNo.	REGION	REVISION	DATE	SIGN
-------	--------	----------	------	------

**REVISIONS**



ARTIFICIAL LIMBS  
MANUFACTURING CORPORATION  
OF INDIA  
KANPUR





DGN	NOM	MAIN TUBE FRAME		
DRN	MTL	ERW STEEL TUBE STKM11A		
CHD	HEAT TREATMENT	_____		
DIM	SURFACE TREATMENT	_____		
SCALE	NTS			
APP	DRG No:-	TD 2 B 36 A A2	REV	SHEET
DATE	15.01.2018		0	10F1

Tolerance wherever not specified

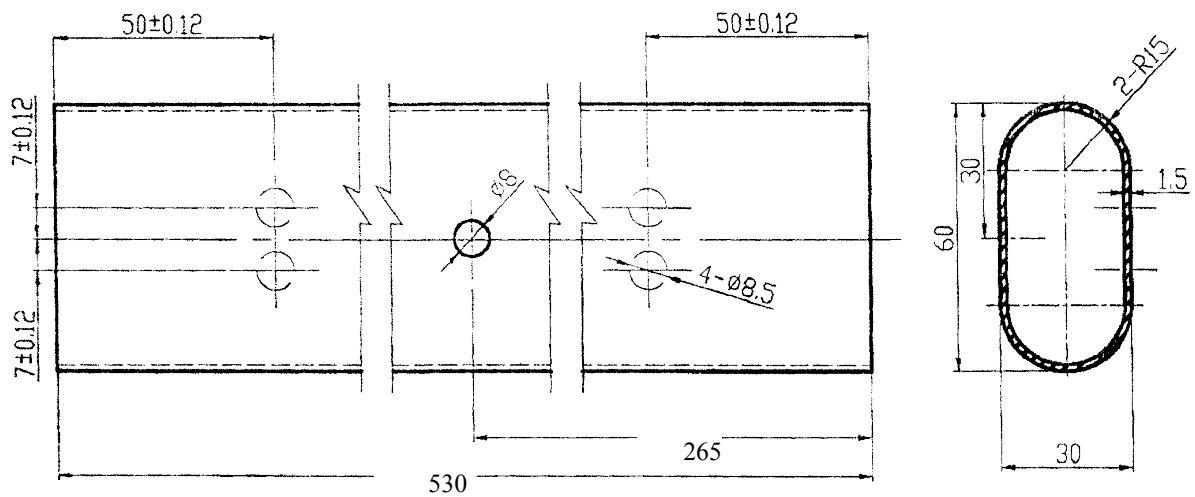
Dim	Tolerance Range		
1 - 16	$\pm 0.2$	$\pm 0.3$	$\pm 0.4$
17 - 63	$\pm 0.2$	$\pm 0.5$	$\pm 0.7$
64 - 250	$\pm 0.3$	$\pm 0.7$	$\pm 1.0$
250 - 960	$\pm 0.5$	$\pm 0.12$	$\pm 1.5$



SNNo.	REGION	REVISION	DATE	SIGN
<b>REVISIONS</b>				
 <b>ARTIFICIAL LIMBS MANUFACTURING CORPORATION OF INDIA KANPUR</b> 				
DGN		NOM	CROSS TUBE FRAME	
DRN		MTL	ERW STEEL TUBE STKM11A	
CHD		HEAT TREATMENT	_____	
DIM	IN mm	SURFACE TREATMENT	_____	
SCALE	NTS 			
APP		DRG No:- TD 2 B 36 A A3	REV 0	SHEET 10F1
DATE	15.01.2018			

Tolerance wherever not specified

Dim	Tolerance Range		
1 - 16	± 0.2	± 0.3	± 0.4
17 - 63	± 0.2	± 0.5	± 0.7
64 - 250	± 0.3	± 0.7	± 1.0
250 - 960	± 0.5	± 0.12	± 1.5

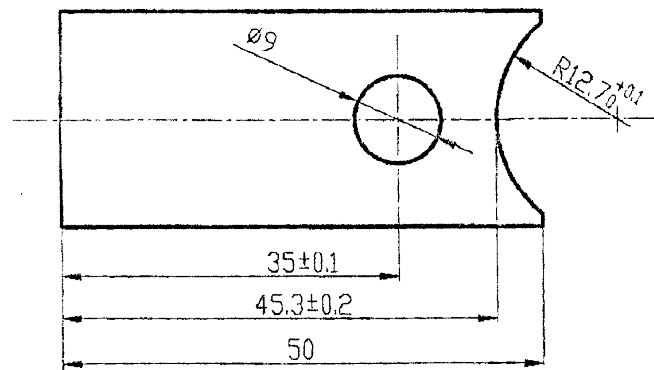
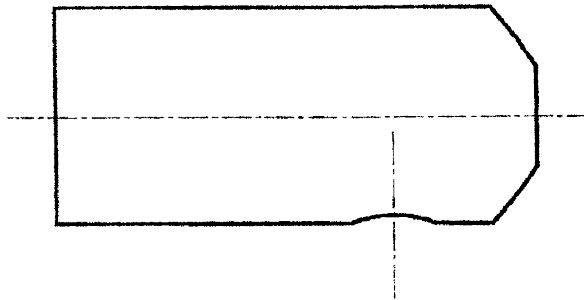
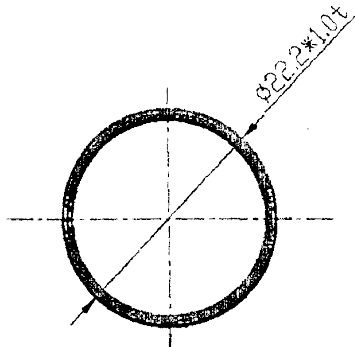

Tolerance wherever not specified

Dim	Tolerance Range		
1 - 16	$\pm 0.2$	$\pm 0.3$	$\pm 0.4$
17 - 63	$\pm 0.2$	$\pm 0.5$	$\pm 0.7$
64 - 250	$\pm 0.3$	$\pm 0.7$	$\pm 1.0$
250 - 960	$\pm 0.5$	$\pm 0.12$	$\pm 1.5$

SNNo.	REGION	REVISION	DATE	SIGN
-------	--------	----------	------	------

### REVISIONS



ARTIFICIAL LIMBS  
MANUFACTURING CORPORATION  
OF INDIA  
KANPUR



DGN	NOM	TUBULAR MOUNTING SOCKET LONG		
DRN	MTL	ERW STEEL TUBE STKM11A		
CHD	HEAT TREATMENT	_____		
DIM	SURFACE TREATMENT	_____		
SCALE	NTS			
APP	DRG No:-	TD 2 B 36 C A6	REV	SHEET
DATE	15.01.2018		0	10F1



5 4 3 2 1

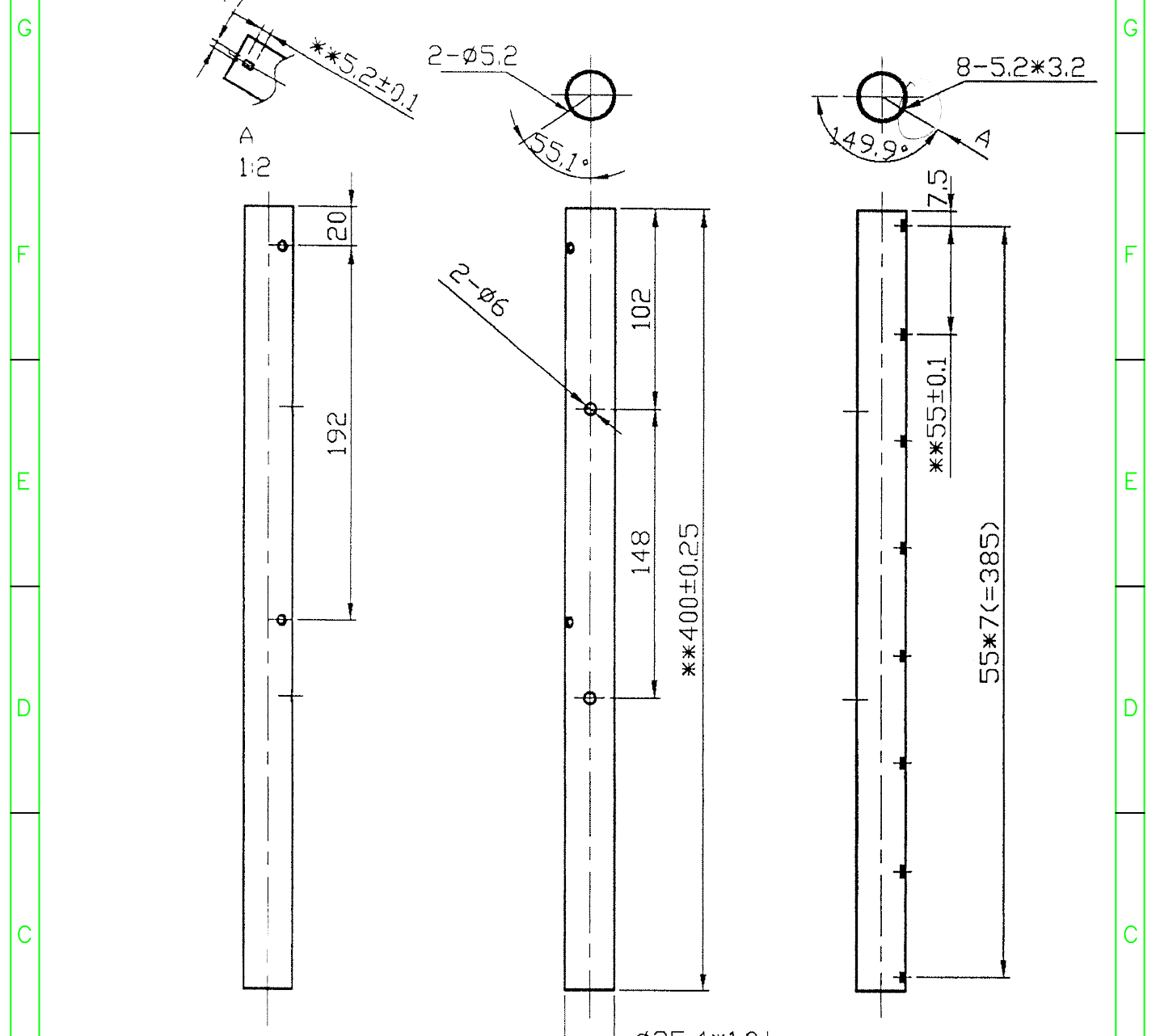

C0.3\*45°

SN0.	REGION	REVISION	DATE	SIGN
------	--------	----------	------	------

**REVISIONS**



ARTIFICIAL LIMBS  
MANUFACTURING CORPORATION  
OF INDIA  
KANPUR



DGN		NOM	X BRACE SEAT TUBE INNER
DRN		MTL	ERW STEEL TUBE STKM11A
CHD		HEAT TREATMENT	_____
DIM	IN mm	SURFACE TREATMENT	_____
SCALE	NTS		
APP		DRG No:-	TD 2 B 37 A A2
DATE	09.02.2018	REV	SHEET 10F1

Tolerance wherever not specified

Dim	Tolerance Range		
1 - 16	± 0.2	± 0.3	± 0.4
17 - 63	± 0.2	± 0.5	± 0.7
64 - 250	± 0.3	± 0.7	± 1.0
250 - 960	± 0.5	± 0.12	± 1.5

5 4

5 4 3 2 1

G

G

F

F

E

E

D

D

C

C

B

B

A

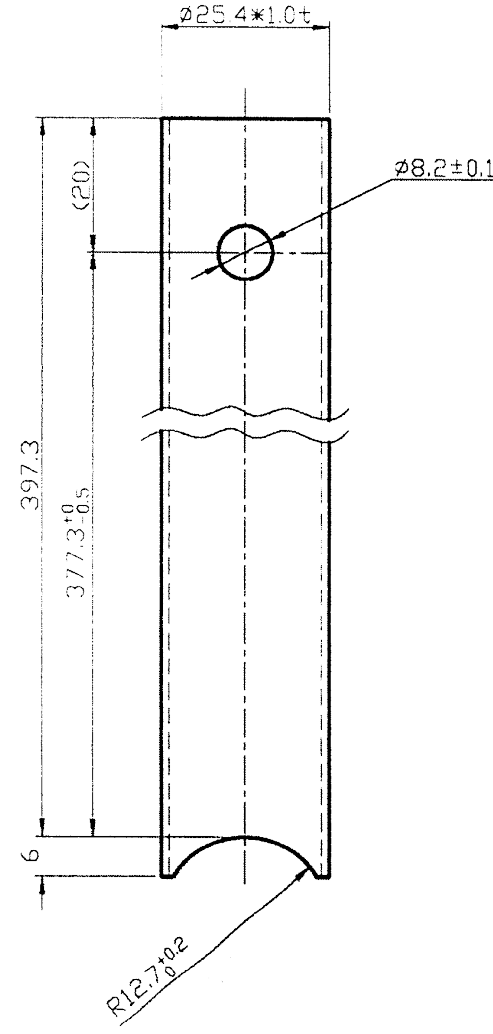
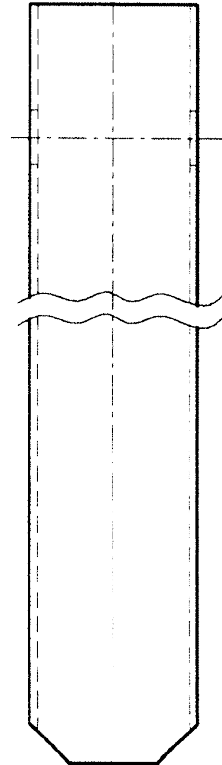
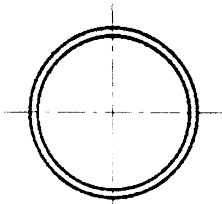

C0.5\*45°

SNNo.	REGION	REVISION	DATE	SIGN
-------	--------	----------	------	------

**REVISIONS**



ARTIFICIAL LIMBS  
MANUFACTURING CORPORATION  
OF INDIA  
KANPUR



DGN		NOM	CROSS BRACE TUBE
DRN		MTL	ERW STEEL TUBE STKM11A
CHD		HEAT TREATMENT	_____
DIM	IN mm	SURFACE TREATMENT	_____
SCALE	NTS		
APP		DRG No:- TD 2 B 37 A A3	REV SHEET 10F1
DATE	09.02.2018		

Tolerance wherever not specified

Dim	Tolerance Range		
1 - 16	$\pm 0.2$	$\pm 0.3$	$\pm 0.4$
17 - 63	$\pm 0.2$	$\pm 0.5$	$\pm 0.7$
64 - 250	$\pm 0.3$	$\pm 0.7$	$\pm 1.0$
250 - 960	$\pm 0.5$	$\pm 0.12$	$\pm 1.5$

5 4

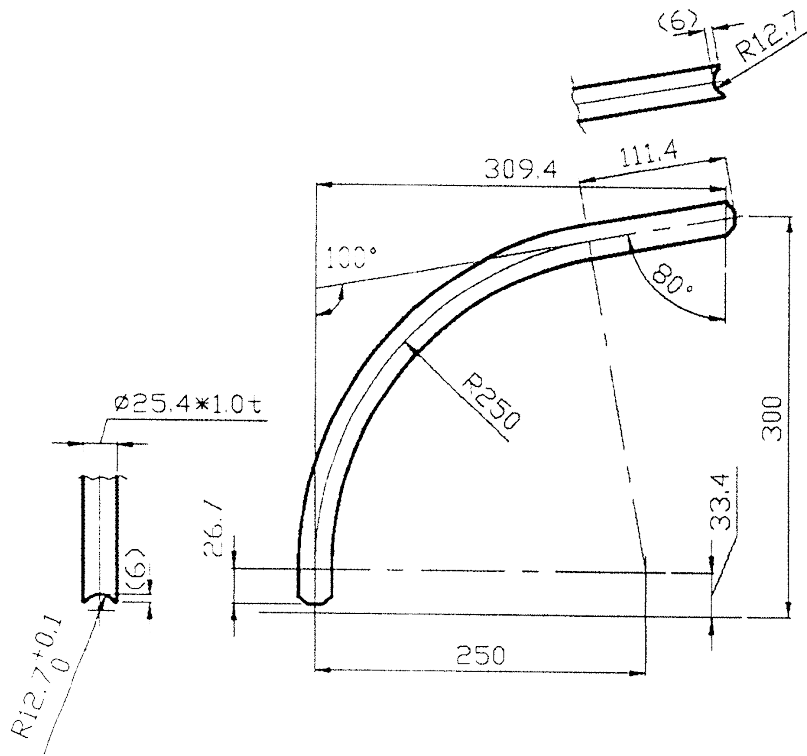

SNNo.	REGION	REVISION	DATE	SIGN
-------	--------	----------	------	------

### REVISIONS



ARTIFICIAL LIMBS  
MANUFACTURING CORPORATION  
OF INDIA  
KANPUR



DGN		NOM	ARM REST TUBE	
DRN		MTL	ERW STEEL TUBE STKM11A	
CHD		HEAT TREATMENT	_____	
DIM	IN mm	SURFACE TREATMENT	_____	
SCALE	NTS			
APP		DRG No:- TD 2 B 37 B A2	REV	SHEET
DATE	09.02.2018		0	10F1

Tolerance wherever not specified

Dim	Tolerance Range		
1 - 16	± 0.2	± 0.3	± 0.4
17 - 63	± 0.2	± 0.5	± 0.7
64 - 250	± 0.3	± 0.7	± 1.0
250 - 960	± 0.5	± 0.12	± 1.5

5

4

3

2

1

G

G

F

F

E

E

D

D

C

C

B

B

A

A

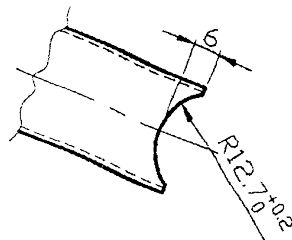
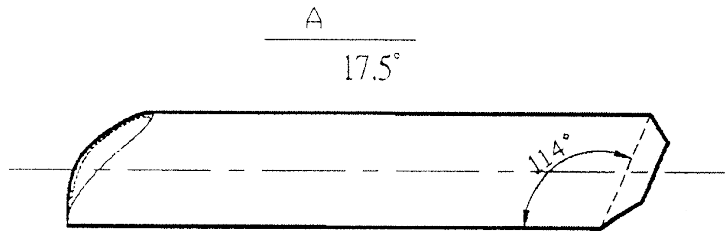
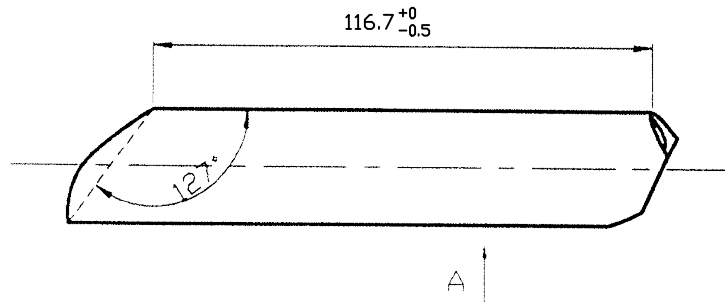
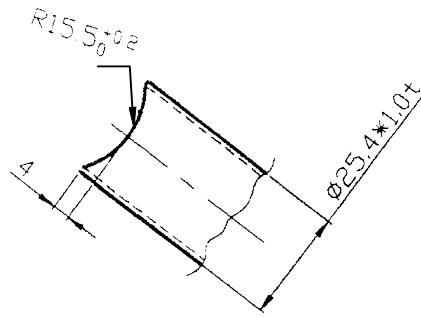

SN0.	REGION	REVISION	DATE	SIGN
------	--------	----------	------	------

### REVISIONS



ARTIFICIAL LIMBS  
MANUFACTURING CORPORATION  
OF INDIA  
KANPUR



DGN		NOM	CASTOR MOUNT TUBE	
DRN		MTL	ERW STEEL TUBE	
CHD		HEAT TREATMENT	_____	
DIM	IN mm	SURFACE TREATMENT	_____	
SCALE	NTS			
APP		DRG No:- TD 2 B 37 B A8	REV	SHEET
DATE	09.02.2018		0	10F1

Tolerance wherever not specified

Dim	Tolerance Range		
1 - 16	$\pm 0.2$	$\pm 0.3$	$\pm 0.4$
17 - 63	$\pm 0.2$	$\pm 0.5$	$\pm 0.7$
64 - 250	$\pm 0.3$	$\pm 0.7$	$\pm 1.0$
250 - 960	$\pm 0.5$	$\pm 0.12$	$\pm 1.5$

5

4

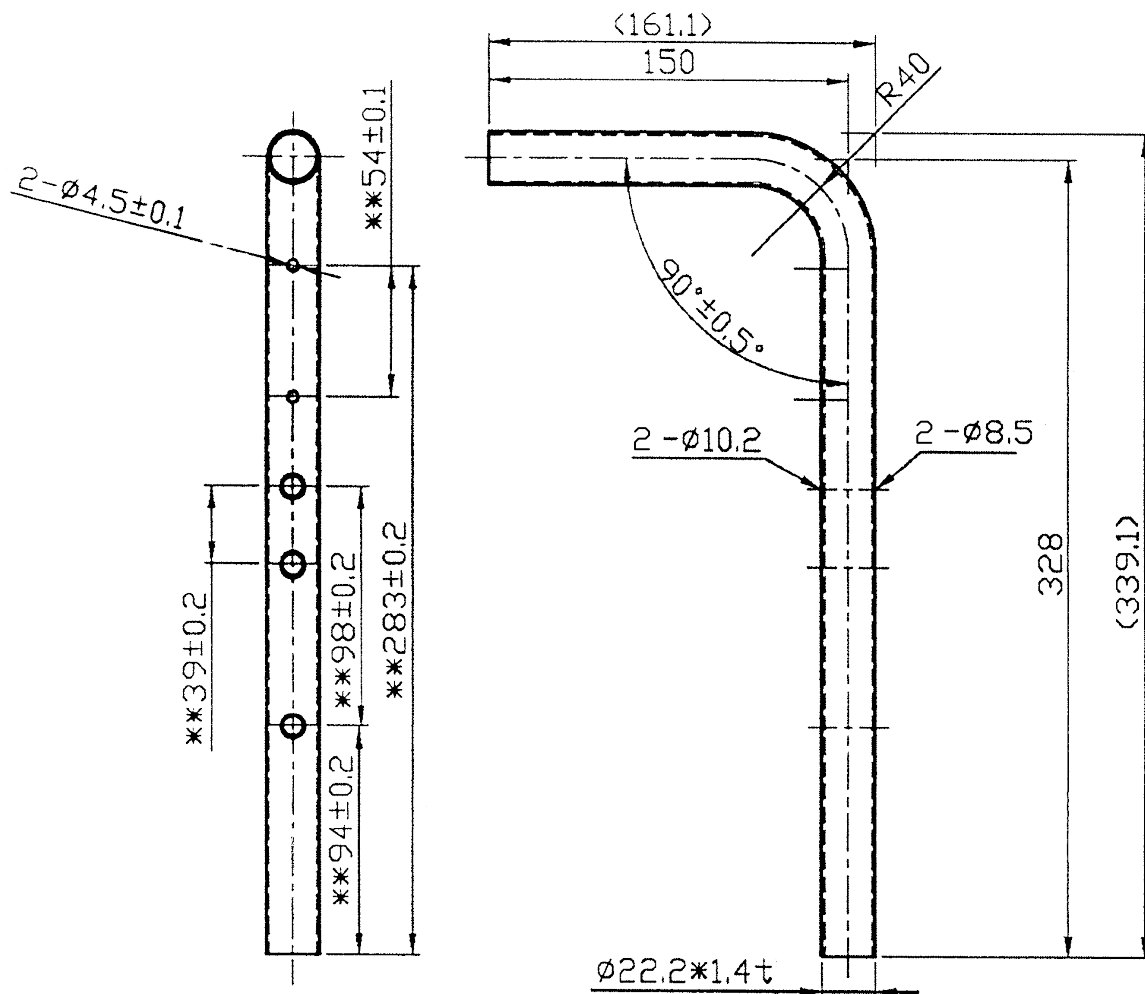

SNNo.	REGION	REVISION	DATE	SIGN
-------	--------	----------	------	------

### REVISIONS



ARTIFICIAL LIMBS  
MANUFACTURING CORPORATION  
OF INDIA  
KANPUR



DGN		NOM	PUSH HANDLE EXTENSION TUBE	
DRN		MTL	ERW STEEL TUBE STKM11A	
CHD		HEAT TREATMENT	_____	
DIM	IN mm	SURFACE TREATMENT	_____	
SCALE	NTS			
APP		DRG No:-	TD 2 B 37 E A1	REV 0
DATE	09.02.2018			SHEET 10F1

Tolerance wherever not specified

Dim	Tolerance Range		
1 - 16	$\pm 0.2$	$\pm 0.3$	$\pm 0.4$
17 - 63	$\pm 0.2$	$\pm 0.5$	$\pm 0.7$
64 - 250	$\pm 0.3$	$\pm 0.7$	$\pm 1.0$
250 - 960	$\pm 0.5$	$\pm 0.12$	$\pm 1.5$