

ALIMCO

**Artificial Limbs Manufacturing Corporation of India,
Auxiliary Production Centre,**

(A GOVERNMENT OF INDIA UNDERTAKING)

Plot No. 40 & 106, Industrial Area, Richhai, Jabalpur-482010

E-TENDER NO. LT/04/MM/JBP/AY, DATE- 11/01/2021

BID SUBMISSION END DATE- 27/01/2021

TENDER DOCUMENTS

FOR

“Machined Component (as per ALIMCO drg.)”

Ref: - LT/04/MM/JBP/AY

Dear Sir,

1. Online tenders are invited for Item as per ALIMCO Specifications/ Drawing of Annexure "A", against Purchase Orders to be placed on the successful Tenderer within specified period as per Purchase Order. Manual bids shall not be accepted.
2. Tender documents may be downloaded from *ALIMCO website www.alimco.in (for reference only) and CPPP website <https://eprocure.gov.in/eprocure/app>*. The tender schedules are mentioned below.

CRITICLA DATA SHEET

Published Date	11/01/2021
Bid Document Download Start Date	11/01/2021
Bid Submission Start Date	11/01/2021
Bid Submission End Date	27/01/2021 (14:00 Hrs)
Sample Submission End Date	-----
Bid Opening Date	28/01/2021 (15:00 Hrs)

Bids shall be submitted online only at CPPP website: <https://eprocure.gov.in/eprocure/app>. Tenderer/Contractors are advised to follow the instructions provided in the 'Instructions to the Contractors/Tenderer for the e-submission of the bids online through the Central Public Procurement Portal for e Procurement at <https://eprocure.gov.in/eprocure/app>.

INSTRUCTION FOR ONLINE BID SUBMISSION

The bidders are required to submit soft copies of their bids electronically on the Central Public Procurement (CPP) Portal i.e. <http://eprocure.gov.in/eprocure/app> , using valid Digital Signature Certificates. The instructions given below are meant to assist the bidders in registering on the CPP Portal, prepare their bids in accordance with the requirements and submitting their bids online on the CPP Portal.

REGISTRATION

- (i) Bidders are required to enroll on the e-Procurement module of the Central Public Procurement Portal by using the "Online Bidder Enrollment" option available on the home page. Enrolment on the CPP Portal is free of charge.
- (ii) During enrolment/ registration, the bidders should provide the correct/ true information including valid email-id & mobile no. All the correspondence shall be made directly with the contractors/ bidders through email-id provided.
- (iii) As part of the enrolment process, the bidders will be required to choose a unique username and assign a password for their accounts.
- (iv) For e-tendering possession of valid Digital Signature Certificate (**Class II or Class III Certificates with signing key usage**) is mandatory which can be obtained from SIFY /nCode/eMudra or any Certifying Authority recognized by CCA India on eToken/ Smartcard.
- (v) Upon enrolment on CPP Portal for e-tendering, the bidders shall register their valid Digital Signature Certificate with their profile.
- (vi) Only one valid DSC should be registered by a bidder. Bidders are responsible to ensure that they do not lend their DSCs to others which may lead to misuse and should ensure safety of the same.
- (vii) Bidders can then log into the site through the secured login by entering their user ID/ password and the password of the DSC/ eToken.

SEARCHING FOR TENDER DOCUMENTS

- (i) There are various search options built in the CPP Portal to facilitate bidders to search active tenders by several parameters. These parameters could include Tender ID, organization name, location, date, value, etc. There is also an option of advanced search for tenders, wherein the bidders may combine a number of search parameters such as organization name, form of contract, location, date, other keywords, etc., to search for a tender published on the CPP Portal.
- (ii) Once the bidders have selected the tenders they are interested in, they may download the required documents / tender schedules. These tenders can be moved to the respective 'My Tenders' folder. This would enable the CPP Portal to intimate the bidders through SMS / e-mail in case there is any corrigendum issued to the tender document.
- (iii) The bidder should make a note of the unique Tender ID assigned to each tender, in case they want to obtain any clarification / help from the Helpdesk.

PREPARATION OF BIDS:

- (iv) For preparation of bid Bidders shall search the tender from published tender list available on site and download the complete tender document and should take into account corrigendum if any published before submitting their bids.
- (v) After selecting the tender document same shall be moved to the 'My favourite' folder of bidders account from where bidder can view all the details of the tender document.
- (vi) Bidder shall go through the tender document carefully to understand the documents required to be submitted as part of the bid. Bidders shall note the number of covers in which the bid documents have to be submitted, the number of documents - including the names and content of each of the document that need to be submitted. Any deviations from these may lead to rejection of the bid.
- (vii) Any pre-bid clarifications if required, then same may be obtained online through the tender site, or through the contact details given in the tender document.
- (viii) Bidders should get ready in advance the bid documents in the required format (PDF/xls/rar/dwf/jpg formats) to be submitted as indicated in the tender document/schedule. Bid documents may be scanned with 100 dpi with black and white option which helps in reducing size of the scanned document.
- (ix) Bidders can update well in advance, the documents such as experience certificates, annual report, PAN, EPF & other details etc., under "My Space/ Other Important Document" option, which can be submitted as per tender requirements. This will facilitate the bid submission process faster by reducing upload time of bids.

SUBMISSION OF BIDS:

- (x) Bidder should log into the site well in advance for bid submission so that he/ she upload the bid in time i.e. on or before the bid submission time. Bidder will be responsible for any delay due to other issues.
- (xi) While submitting the bids online, the bidder shall read the terms & conditions (of CPP portal) and accepts the same in order to proceed further to submit their bid.
- (xii) Bidder shall digitally sign and upload the required bid documents one by one as indicated in the tender document.
- (xiii) Bidders shall note that the very act of using DSC for downloading the tender document and uploading their offers is deemed to be a confirmation that they have read all sections and pages of the tender document without any exception and have understood the complete tender document and are clear about the requirements of the tender document.
- (xiv) Bid documents may be scanned with 100 dpi with black and white option which helps in reducing size of the scanned document. For the file size of less than 1 MB, the transaction uploading time will be very fast.

- (xv) If price quotes are required in XLS format, utmost care shall be taken for uploading Schedule of quantities & Prices and any change/ modification of the price schedule shall render it unfit for bidding. Bidders shall download the Schedule of Quantities & Prices i.e. [Schedule-A, in XLS format and save it without changing the](#) name of the file. Bidder shall quote their rate in figures in the appropriate cells, thereafter save and upload the file in financial bid cover (Price bid) only. [If the template of Schedule of Quantities & Prices file is found to be modified/corrupted in the eventuality by the bidder, the bid will be rejected and further dealt as per provision of clause no 23.0 of ITB including forfeiture of EMD. The bidders are cautioned that uploading of financial bid elsewhere i.e. other than in cover 2 will result in rejection of the tender.](#)
- (xvi) Bidders shall submit their bids through online e-tendering system to the Tender Inviting Authority (TIA) well before the bid submission end date & time (as per Server System Clock). The TIA will not be held responsible for any sort of delay or the difficulties faced during the submission of bids online by the bidders at the eleventh hour.
- (xvii) After the bid submission (i.e. after Clicking “Freeze Bid Submission” in the portal), the bidders shall take print out of system. After the bid submission (i.e. after Clicking “Freeze Bid Submission” in the portal), the bidders shall take print out of system generated acknowledgement number, and keep it as a record of evidence for online submission of bid, which will also act as an entry pass to participate in the bid opening.
- (xviii) Bidders should follow the server time being displayed on bidder’s dashboard at the top of the tender site, which shall be considered valid for all actions of requesting, bid submission, bid opening etc., in the e-tender system
- (xix) All the documents being submitted by the bidders would be encrypted using PKI (Public Key Infrastructure) encryption techniques to ensure the secrecy of the data. The data entered cannot be viewed by unauthorized persons until the time of bid opening. The confidentiality of the bids is maintained using the secured Socket Layer 128-bit encryption technology.

ASSISTANCE TO BIDDERS:

- (i) Any queries relating to the tender document and the terms and conditions contained therein should be addressed to the Tender Inviting Authority for a tender or the relevant contract person indicated in the tender. The contact number for the [helpdesk is 011-29571526 between 10:30 hrs. to 17:00 hrs.](#)
- (ii) Any queries relating to the process of online bid submission or queries relating to CPP Portal in general may be directed to the directed to the 24X7 CPP Portal Helpdesk. [e-Mail id is support-eproc@nic.in.](#)
- (iii) [If any query is not resolved by the CPP Portal Helpdesk, you may contact the Nodal Officer \(Procurement\), ALIMCO Toll Free Number: 1800-3070-2232.](#)



IS/ ISO 9001:2015

INVITATION TO QUOTE (E-TENDER)

**ALIMCO - AUXILIARY PRODUCTION CENTRE,
ARTIFICIAL LIMBS MANUFACTURING CORPORATION OF INDIA**
(A GOVT. OF INDIA UNDERTAKING)

Work & Office: Plot No. 40 & 106, Industrial Area, Richhai, Jabalpur-482010 (M.P.)

Telephone: 0761-2334717, Web: www.alimco.in

E-mail: mm.jabalpur@alimco.in , aapc_jabalpur@alimco.in

[HEAD OFFICE: ALIMCO, G.T. ROAD, KANPUR-209217 (U.P)]



CIN: U85110UP1972NPL003646

GSTIN: 23AABCA8899F1ZG

Ref. No.: LT/04/MM/JBP/AY

dated: 11/01/2021

REF: - E-TENDER NO. LT/04/MM/JBP/AY
Due Date for Opening: 28/01/2021

Dear Sir,

1. Online e-tenders are invited for two bid system i.e. Technical Bid (TC-Bid) & Price Bid (P-Bid) for the supply as per Annexure-"A" (as per ALIMCO Drawings / specifications) against our Purchase Orders to be placed on the successful Tenderer / Tenderers within a period of Twelve months from the date of finalization of 1st Purchase Order, extendable for a further duration for 01 year or more by mutual consent. Manual bids shall not be accepted/entertained/processed further.

2. **The tentative quantities likely to be covered by Purchase Orders are indicated at ANNEXURE 'A'. The material would be required to be supplied on staggered delivery schedule to its ALIMCO-APC, Jabalpur the total requirement of above material may vary substantially from the quantity indicated in ANNEXURE- 'A'. The tentative monthly requirement will be approx 1/12th of the quantity indicated in Annexure 'A' subject to changes by the Corporation which may vary substantially up or down as per requirement of the Corporation & the successful tenderer will be required to arrange supplies accordingly.**

The Corporation has right to place Order for an additional quantity equal to 100% of the original Order with the successful bidders at same rates, terms & conditions within a period of 06 months from the date of last supply or during the currency of the Order.

3. Offer of supply will have to be made as per the following terms and conditions: -

A. SUBMISSION OF E-TENDER

A-1. The detailed tender documents may be downloaded from <http://eprocure.gov.in/eprocure/app> till the last date of submission of e-tender. The Tender must be submitted online through CPP Portal. Tender shall be submitted online in Techno-Commercial Bid 'TC' BID for which the format is also enclosed at Annexure-I and Price Bid 'P' BID for which the formats are also enclosed at Annexure II.

Pre Qualification/Mandatory criteria/ Parameters: -

A-2. Procedure for submission of tender documents shall be as under: -

- a) Part I (TC- BID) Signed and Scanned copy of the Technical bid documents as under must be submitted Online on CPP Portal: <http://eprocure.gov.in/eprocure/app> (List of all requisite Documents to be scanned and uploaded (Under Cover 1) within the specified period of bid submission) , However, if required sample must be physically submitted on the given address in office of “ALIMCO-APC, Jabalpur” which must be received on or before bid Submission End date as specified in the tender & Scanned copies of the same must be Uploaded online in Cover1.
- i) Scanned Copy of GST Registration Certificate, if applicable, duly signed & stamped, clearly mentioning the GSTIN number.
 - ii) Specific Confirmation in the format enclosed at Annexure ‘B1’ to the effect that the material quoted/to be supplied is/will be as per ALIMCO Specifications & drawing alongwith requisite Test Certificate **format to the effect is enclosed at Annexure ‘B-1’.**
 - iii) The tenderer has to submit an undertaking to supply the additional quantity of material equal to 100% of the Order quantity at the same rates and terms & conditions if Ordered within a period of 06 months from the date of last supply or during the validity of Order **in the format enclosed at Annexure ‘B-2’.**
 - iv) The tenderer should submit an undertaking that his/her firm has not been debarred to participate in the tender by any Govt. Institution, PSUs, State Govt. or Central Govt. Deptt. **in the format enclosed at Annexure-B-3.**
 - v) The tenderer should submit an undertaking that his/her Offer is valid for acceptance for 90 days from the date of opening of TC- Bids **in the format enclosed at Annexure-B-4.**
 - vi) The tenderer should submit an undertaking that the payment terms regarding payment of basic amount within 30 days after supply & acceptance/approval of material or submission of bill whichever is later and subsequent payment of GST as specified **in the format enclosed at Annexure-B-5** is acceptable to them.
 - vii) The tenderer should submit an undertaking of Tender acceptance letter in the format enclosed at **Appendix I**

(All these documents / details / confirmation should necessarily be submitted specifically & in the same order as mentioned above.)

NOTE:

- (i) Only sample (if applicable) must physically be submitted on the given address to office of "ALIMCO-APC, Jabalpur" which must be received on or before Bid Submission End date as specified in the tender & Scanned copies of the same must Uploaded online in cover 1.
- (ii) Vendors shall be allowed to submit the sample only once alongwith the Tender. However, Corporation in its sole discretion may request tenderers to submit fresh sample in case of rejection of the sample submitted by the tenderer alongwith their TC-Bid, within 10 working days of communication by the Corporation alongwith reason of rejection through e-mail failing which the option to submit second sample will stand lapsed. In case, the second sample also gets rejected/fails, no further opportunity will be given to the tenderer to submit the sample. Just as in case of Tender Sample, only two opportunities shall be allowed for submission of advance sample before the supplies against the purchase order to the successful bidder.
- (iii) Similarly, the Corporation in its sole discretion may seek clarifications/required documents, if any from the bidders, if considered necessary only once. The same will be required to be submitted by bidders within 10 working days beyond this period this opportunity will stand lapsed & no further opportunity will be provided.
- (iv) **The Corporation in its sole discretion has right to depute a Technical Committee at TC-Bid/Technical evaluation stage to visit the work place/Factory of the tenderer/tenderers to ascertain the capability/capacity of the tenderer/tenderers, if felt necessary by the Corporation. The recommendation of the Technical Committee regarding acceptance/non-acceptance of the offer/offers shall be binding on the tenderers. No representation against the recommendation/decision of the Technical Committee/Corporation shall be admissible/entertained.**
- (v) **The testing/evaluation of samples shall be done with the testing facilities available in the Corporation/Outside Agency by/through the available manpower of the Corporation. The test/evaluation of samples by the Corporation shall be final and binding on the tenderers and no correspondence/representation in this respect shall be admissible/ entertained.**
- (vi) Price bids of only those tenderers, who are assessed as technically qualified by the Corporation shall be opened.
- (vii) **Submission of Offer against this tender shall be construed as unconditional acceptance of all terms and conditions laid down in this tender.**

(B) Part II (Financial / Price Bid)

- (i) The currency of all quoted rates shall be Indian Rupees. All payment shall be made in Indian Rupees.
- (ii) In preparing the financial bids, bidders are expected to take into account the requirements and conditions laid down in this Tender document. The financial bids should be uploaded online as per the specified ".xls" format & details given in Annexure-II. (Excel sheet attached as '.xls' with the tender. It should include all costs associated with the Terms of Reference/Scope of Work of the assignment).
- (iii) Specifically, the offer must be quoted with complete breakup i.e. **Basic Price, packing forwarding, freight, applicable GST along with HSN Code/Tax. In case no % in Freight & Packing Forwarding mentioned, Basic rate quoted shall be deemed to be inclusive of Freight and P & F charges.**
- (iv) The Financial bid should be according to the. Xls format given in the Tender Document. It should be ensured that no required value against an item is missed. If the bidder does not want to charge for an item, the value must be filled as "0" (ZERO).
- (v) **The Price Bid shall contain price for supply up to ALIMCO-APC, Jabalpur mentioning complete breakup i.e. Basic Price, packing forwarding, freight, applicable GST along with HSN Code/Tax as per the format at Annexure -II. (If zero '0' is quoted in Packing & forwarding and freight; Basic Price would be deemed to be including freight and packing & forwarding.)**

vi) Please note that no indication with regard to the rates / amounts in any of the documents submitted along with 'TC' BID is required to be given /mentioned.

vii) The Tender should be uploaded/submitted online well within specified time & date and Samples, if applicable (as per Annexure-A) should be dispatched/submitted physically well in time so that the same should reach on or before Bid Submission End Date. The Tenderers may in their own interest, send their hard copies, samples etc, by Registered / Speed Post (Acknowledgement due), but postal and transit delays may not be considered for reckoning the tenders as 'VALID' for our considerate.

viii) ALIMCO reserve the right to open Price Bid of successful Techno Commercial Bidders only and also reserve the right to split up total order quantity among two/three bidders and at its discretion. In case of split up of quantities upto two bidders, 60% quantity will be placed on L1 and 40% quantity on L2 provided L2 agrees to match rates with L1. In case of split of quantity upto 3 parties, 60% of the quantity may be placed on L1 and 20% each on L2&L3 provided they agree to match L1 rates. In case L2 and L3 refuse to match L1 rates, the entire quantity of supplies will be ordered to L1 party. Moreover, in case one of the parties i.e. L2 and L3 refuses to match L1 rate, the supplies will be divided in 60:40 ratio among L1 and L2/L3 parties as the case may be.

ix) L1 tenderer is the party whose nett rates inclusive of Basic rate, Packing & forwarding & freight, excluding applicable GST rate/amount, work out to be lowest against the tender. (L-1 Tenderer whose rates i.e. net cost to company after taking into account the input tax credit works out to be the lowest).

(x) **Submission of Tender:** - Online tenders complete in all respects, must be submitted /uploaded on line on or before the last date and time as specified in the schedule of events. The ALIMCO may, at its own discretion, alter/extend the last date for submission of tenders. Tenderers are required to send, if applicable, sample along with relevant document addressed to ALIMCO-APC,Jabalpur on or before 27/01/2021.

Tenderers must also indicate the following particulars on the face of the envelope containing requisite sample (if applicable).

- a) Name & Address of the Tenderer
- b) Tender No.LT/04/MM/JBP/AY for the supply of Machined Component.

Due on: 28/01/2021 (In case, the last date of submission/opening of tender is declared holiday/closed, the same shall be extended to the next working day automatically without any change of timing for submission/opening of tender.)

OPENING OF E-TENDER
Due Date of E-Tender: 28/01/2021

B-1. All the tenderers must submit their tender on line using CPP portal <http://eprocure.gov.in/eprocure/app> by on or before date & time as per Critical Data Sheet. If the due date happens to be a holiday the same stands extended to the date of next working day with time remaining the same. However, the Corporation has the right to alter the date & time of Tender closing & opening. The same shall be notified only on the website of the Corporation.

B-2 Late Tenders and sample, if specified in tender, not received on or before due date will not be considered. Tenders from black listed/debarred parties during the currency of debarring/blacklisting period for the quoted items shall not be considered and summarily rejected.

B-3 Rectification of arithmetical errors: - While scrutinizing the Tenders if a difference is detected between the unit price and the total price the former will prevail. In case of discrepancy between the figures and words, the latter would prevail. The arithmetical errors mentioned above shall not be the cause of rejection of a Tender.

- B-4** If a Tender does not substantially confirm to the specifications or contains inadmissible reservations or exception to the Tender documents or does not otherwise substantially respond to the Tender documents and or have conditional offers it should be rejected.
- B-5** Only the 'TC'BID (Cover1) of the tender will be opened (online) on due date of opening at 1530 Hrs. (Refer Critical Data Sheet) by the Tender Opening Committee of ALIMCO-APC, Jabalpur in presence of respective of tenderes who may like to be present (online) and the following procedure will be followed: -
- i) The Tender Opening Committee of ALIMCO-APC, Jabalpur shall open (online) cover 1 i.e. 'TC'BID part of all tenders Tender Opening Committee in presence of tenderers. (if present on line during opening of tenders) The Evaluation Committee shall go into details of technical bids parameters (TC-BID & Sample, if applicable) and Price Bid of only those Tenderers shall be opened whose TC Bid & sample (if applicable) are found / assessed to be acceptable at the sole discretion of the Corporation.
 - ii) The Corporation in its sole discretion has the right to seek further clarifications/ documents from the tenderers relating to 'TC-Bids' of the tenderers, if such information is essential.
 - iii) In case, if any tenderer submits only 'TC-Bid' or 'P-Bid' against the tender, the same shall be treated as incomplete and Offer shall be summarily rejected.

C. VALIDITY OF TENDER

C-1. The offers shall remain open for acceptance for a minimum period of 90 days extendable by mutual consent from the date of opening of tender. Any tender having validity of less than 90 days shall not be considered and the Offer shall be summarily rejected.

C- 2. If notified within this period that the tender has been accepted, the tenderer shall be bound by the terms of the offer along with the terms that have been agreed to mutually.

C-3. All tenders without PROPER SPECIFICATION/ MAKE/ BRAND AND TEST CERTIFICATES, wherever required, are liable to be rejected. The successful Tenderer/Tenderers shall also be required to submit requisite Test certificate along with the supplies if required as per Annexure - 'A'.

C-4 The Corporation would provide the necessary GST Tax Forms to facilitate dispatch /sale of material directly to the Corporation. **Tenderers should indicate their GST registration number & respective HSN code/s of items without fail.**

C-5. In case tenderers happen to be a dealer / distributor for any Brand, a copy of authorization certificate to this effect duly certified from the principal for validity should invariably be provided.

D. DETAILS OF OFFER

D-1. (i) Rate should be quoted in Rupee per unit in figures and in words. In case of any difference, the figures given in words will only be considered and binding. Rate should be quoted along with Packing & Forwarding, Freight charges with applicable GST etc, for DELIVERY at premises of ALIMCO-APC, Jabalpur. The offers other than "FOR ALIMCO-APC, Jabalpur delivery will summarily be rejected. The following data shall invariably be furnished: -

- (a) Basic Price in `.
- (b) Packing & Forwarding Charges, if any, in % & `.
- (c) Freight Charges in % & `.
- (d) Good & Service Tax (GST) along with HSN code, if any, applicable in % `.

ii) **Offers for supplies other than FOR Free delivery / Ex-shop / Ex-works, Jabalpur at ALIMCO-APC, Jabalpur will be summarily rejected.**

iii) **If nothing is mentioned, the prices will be deemed to be FOR:- ALIMCO-APC, Jabalpur.**

D-2. All entries in the offers shall be either typed or neatly hand written. Tender having over writings / fluid application / cutting etc. without proper authentication will be rejected.

D-3. No Toolings / Die development charges are payable by the Corporation in case the same is required to be developed for making the supplies/ samples.

E. TAXES

E-1. The Good & Service Tax (GST) applicable, the rate should be given clearly and separately with their HSN Codes. **The offer quoted inclusive of GST Taxes (if applicable), Packing & Forwarding charges and freight charges will summarily be rejected.**

E-2. ALIMCO-APC, Jabalpur Good & Service Tax (GST) Registration No. is - **23AABCA8899F1ZG**

E-3. Variation Clause: - Any change (Increase / Decrease) in Govt. Duties / Levies / GST as amended made applicable by Govt. (State / Central) from time to time at the rate as will be applicable over & above the basic price/rate quoted by parties in their offer during the currency of Purchase Order/Contract shall be considered by the Corporation for amendment on party's request alongwith necessary documents in support of their claim/amendment.

E-4. The tenderers are required to quote with correct rate of GST taxes along with HSN code for quoted items etc. as applicable. P.O. shall be placed as per quotation. Any request for upward revision of quoted HSN code / rate of GST rate on account of ignorance / mistake while quoting shall not be entertained and shall be on account of tenderer.

F. DELIVERY TERMS & CONDITIONS

F-1 The Tenderer will be bound to make supplies as per delivery schedule specified in the Order or as amended by the Corporation failing which Corporation may take appropriate action as per Clause No. F-6 & F-7 of Tender Document.

F-2 The delivery term is FOR ALIMCO-APC, Jabalpur and Validity of tender 90 days.

F-3 Force Majeure: - In the event that the Supplier or any of its subcontractors, or the purchaser is delayed in performing any of its respective obligations under the Contract, and such delay is caused by Force Majeure, including but not limited to war, civil insurrection, fires, floods, epidemics, earthquakes, quarantine restrictions and freight embargoes, such delay may be excused and the period of such delay may be added to the time and performance of the obligation delayed.

F-4. Tenderers shall be bound to supply materials against Purchase Orders placed on them during the contract period of one year which may be further extended by 01 year or more by mutual consent at same terms & conditions.

F-5. The delivery schedules may be altered or the Order may be short closed by ALIMCO without assigning any reason by providing 30 days notice.

F-6. The supplies shall be made in proper packing to avoid any damage/loss/pilferage in transit & storage.

F-7. The delivery of the stores shall be made strictly as per delivery schedule conveyed or as modified from time to time. In case the Supplier / Contractor fails to supply the material or provide services as per schedule stipulated in Purchase Order / Work / Service Contract, the Purchaser i.e. the Corporation will have the right to cancel the Purchase Order / Work / Service Contract at the risk and cost of the defaulter contractor/ supplier who shall be liable to compensate the Corporation for loss or inconvenience suffered by it and the administrative action including suspension, banning etc. which the Corporation may decide to take against the defaulter. The Corporation shall also have the right to levy liquidated damages for delays in supply/ execution of the contract. The Liquidated damages shall be levied at the rate of point five percent (i.e. ½% or 0.5%) per week or fraction of a week subject to the maximum of 10% of the contract value. In addition to 10% of LD, GST @18% will be separately deducting on Liquidated damages (LD) Amount.

F-8. The supply of all items shall be completed satisfactorily within the stipulated delivery period of the order failing which ALIMCO reserves the right to obtain / purchase stores from other sources at your sole risk, responsibility and cost. If any higher price has to be paid above the contracted price, the loss which may occur on this account, shall be recovered from the tenderer.

F-9. Other terms & conditions of supplies shall be as stipulated in the Purchase Order to be placed against this tender.

G. INSPECTION AND REPLACEMENT/DISPOSAL OF MATERIAL IN CASE OF REJECTION

G-1. Inspection of supplies will be carried out at the premises only of ALIMCO-APC, Jabalpur which shall be final & binding on tenderer.

G-2. In case of local supplier, rejected material shall be lifted/ collected from our stores within 10 days after receipt of our rejection advice or latest within 15 days from the date of our letter whichever is earlier, after refunding the payment, if already made to them.

G-3. Unacceptable / rejected material will be returned to the outstation supplier at the suppliers' risk and cost by road on their request on freight to pay basis, only after receipt and acceptance of replacement supplies provided by the suppliers free of cost. Alternatively, the Tenderers will have to furnish their banker's name, address including Code Number along with a declaration/ undertaking to guarantee collection of documents for returned supplies negotiated through their bank, within 07 days of its presentation.

G-4. If due to any reason, the lifting/ collection of rejected material is delayed by the tenderer beyond 15 days the Corporation shall be entitled to charge inventory carrying cost for period beyond 15 days. However, The Corporation will not hold the rejected materials beyond 45 days & may dispose of the rejected materials as deemed fit at supplier's cost and no claim whatsoever shall be entertained/admissible at all in this respect. Any loss/ expenses incurred in this connection would be to the supplier's accounts.

H. GENERAL

H-1. The successful tenderer shall not sub contract the supplies covered under the Purchase Orders.

H-2. Any post tender offer would be rejected summarily and may also result into debarring/ black-listing of the parties making such offer.

H-3. Any bribe, commission, gifts or advantage given, promised or offered by the Tenderer or on behalf of the Tenderer or his partner, agent or servant or anyone on his or their behalf (whether with or without the knowledge of the Tenderer) to any officer, servant, representative or agent of the Corporation in relation to the obtaining or to the execution of this or any other contract with the Corporation shall be in addition to any criminal liability which he may incur, subject the Tenderer to the cancellation of this and all other contracts and also to payment to Corporation of any loss resulting from any such cancellation.

H-4. The tenderers should necessarily enclose the complete specification / technical details/ exhaustive literature / printed catalogue of their offered products / equipments indicating any special features of their offered products.

H-5 **General Lien:-** Whenever, under this Purchase Order / Work Contract any sum of money is recoverable from and payable by the contractor, the Corporation shall be entitled to recover such recoverable, as may be, shall be deducted from any sum due to the Contractor or which at any time thereafter may become due to the Contractor under this or any other Contract with the Corporation Should this sum be not sufficient to cover the full amount recoverable the Contractor shall pay to the Corporation on demand the remaining balance due. **The other terms & conditions of corporation's Purchase Policy shall be applicable.**

J. TERM OF PAYMENT

ALIMCO is a Schedule 'C' Miniratna Category II Central Public Sector Enterprises, registered under Section 8 (Not for Profit motive) of the Companies Act, 2013, (corresponding to Section 25 of the Companies Act, 1956)

- i) Payment of Basic amount will be made within 30 days after receipt of acceptable supplies without any damage / short supplies or from submission of bills whichever is later. However, the GST portion will be payable only after submission of proof / self-certified copy of GST return filed online by the tenderer clearly (duly highlighted) showing invoice/ bill number and amount submitted to ALIMCO.
- ii) Advance payment terms or payment against delivery or terms of payment other than (i) above are not acceptable to the Corporation. Such Offers will be summarily rejected.
- iii) The Corporation would not bear any overdue interest / demurrage charges for non receipt of material.
- iv) All bank charges to be borne by tenderer.
- v) The successful Tenderer will be required to submit their RTGS details duly certified by the Bank or along with a crossed/cancelled Cheque in support of the details, as all payments are proposed to be made through RTGS only.

K. RIGHT OF ACCEPTANCE

ALIMCO reserves the right to reject any or all the tenders in part or full and / or to negotiate terms and conditions of supply and to amend the quantity against the Order without assigning any reason thereof. The Corporation also reserves the right to Short close / cancel the Order by giving one month notice at its sole discretion as deemed fit without assigning any reason thereof.

L. THIS IS A FIXED PRICE TENDER. ANY REQUEST FOR RATE REVISION TILL CURRENCY OF P.O. SHALL NOT BE CONSIDERED.

M. Amendment of Purchase Order Quantity

The Corporation has right to amend the Tender/Purchase Order Quantity (enhanced/reduced) in case of change/amendment in the Production schedule during currency of Purchase Order to meet out the Corporation's target/commitments as per customer's/Marketing department requirement.

N. Banning, Debarring/Black-Listing of parties, Suspension of business with them will be dealt as per guidelines of Purchase Policy of the Corporation available on its website - www.alimco.in.

O. The Tenderer are required to provide their e-mail address, postal address and telephones/cell number etc. necessarily on their letter head.

P. ARBITRATION

If any dispute / question or controversy arises, the settlement of which is not herein specifically provided in this Tender / Order/ Contract, the matter in dispute shall be referred to the arbitration of the Chairman and Managing Director of ALIMCO or his nominee and decision of Chairman and Managing Director or his nominee shall be final and binding on both the parties. The provision of INDIAN ARBITRATION & CONCILIATION ACT,1996 as amended from time to time, shall apply to such arbitration proceedings. Arbitration proceeding shall be held at Kanpur only and the Kanpur Nagar Court will have jurisdiction in the matter.

Thanking you,

**Yours faithfully,
For- Artificial Limbs Mfg. Corporation of India**

**Material Management Deptt.
AAPC-Jabalpur**

Techno-Commercial Bid (TC-Bid) – On line Submission (Cover 1)

Annexure – I

Tender No.: **LT/04/MM/JBP/AY**

Item: - Machined Component

Please furnish the following details in the given Proforma.

1	Copy of GST Registration Certificate, duly signed & stamped, clearly mentioning the GSTIN number.	i) Registration No..... ii) Copy of Certificate Enclosed Yes/No
02	Specific Confirmation in the format enclosed at Annexure 'B1' to the effect that the material quoted/to be supplied is/will be as per ALIMCO Specifications & drawing alongwith requisite Test Certificate Format to the effect is enclosed at Annexure 'B-1' .	Confirmation enclosed – Yes/No
03	The tenderer has to submit an undertaking to supply the additional quantity of material equal to 100% of the Order quantity at the same rates and terms & conditions if Ordered within a period of 06 months from the date of last supply or during the validity of Order in the format enclosed at Annexure 'B-2' .	Undertaking Enclosed - Yes/No
04	The tenderer should submit an undertaking that his/her firm has not been debarred to participate in the tender by any Govt. Institution, PSUs, State Govt. Or Central Govt. Deptt. in the format enclosed at Annexure-B-3.	Undertaking enclosed – Yes / NO
05	The tenderer should submit an undertaking that his/her Offer is valid for acceptance for 90 days from the date of opening of TC Bids in the format enclosed at Annexure-B-4.	Undertaking enclosed - Yes / NO
06	The Tenderer should submit an undertaking that the payment terms of basic amount within 30 days and subsequent payment of GST as specified in the format enclosed at Annexure-B-5 is acceptable to them	Undertaking enclosed - Yes / NO
7	The tenderer should submit an undertaking of Tender acceptance letter in the format enclosed at Appendix I	Undertaking enclosed - Yes / NO

(Signature & Seal)

- Note :**
1. All documents Scanned copy to be uploaded ON LINE using <https://eprocure.gov.in/eprocure/app.in> Cover 1).
 2. However, Sample if applicable clearly mentioning Tender No. **LT/04/MM/JBP/AY** and Bid Submission End Date: **27.01.2021**, should be sent by Registered/ Speed post Acknowledgement so as to reach the same on or before the Bid submission end date & time addressed to ALIMCO-APC, Jabalpur but postal and transit delay may not be condoned in reckoning the tenders for our consideration.

Price Bid (P-Bid) Submission in .xls format as per details given below: -

Tender No.: **LT/04/MM/JBP/AY**

Please furnish the details in the given XLS. Proforma as available/through online on CPP Portal <http://eprocure.gov.in/eprocure/app>

S.NO	FOR SUPPLY TO DESTINATIONS	ANNEXURE DETAILS
1	ALIMCO-APC, Jabalpur	ANNEXURE -II in xls. formats

NOTE:

- i) The rates should be invariably and Separately quoted for supplies to ALIMCO-APC, Jabalpur
- ii) **The basic Price/rate, GST Taxes, along with HSN code, Packing & Forwarding charges and Freight charges must be mentioned separately & specifically in the respective .xls formats as available on CPP Portal <http://eprocure.gov.in/eprocure/app>.**
- iii) Maximum quantity which can be delivered/supplied per month may normally be not less than our average monthly requirement:
- iv) Maximum period required to commence supplies which may normally be not exceeding 30 days from the date of placement of Purchase Order.
- v) ALIMCO reserve the right to open Price Bid of successful Techno Commercial Bidders only and also reserve the right to split up total order quantity among two/three bidders and at its discretion. In case of split up of quantities upto two bidders, 60% quantity will be placed on L1 and 40% quantity on L2 provided L2 agrees to match rates with L1. In case of split of quantity upto 3 parties, 60% of the quantity may be placed on L1 and 20% each on L2&L3 provided they agree to match L1 rates. In case L2 and L3 refuse to match L1 rates, the entire quantity of supplies will be ordered to L1 party. Moreover, in case one of the parties i.e. L2 and L3 refuses to match L1 rate, the supplies will be divided in 60:40 ratio among L1 and L2/L3 parties as the case may be.

(TO BE FILLED UP IN DUPLICATE AND ENCLOSED WITH SAMPLES & TC-BID)

LIST OF ITEMS BEING SUBMITTEDTender No.: - **LT/04/MM/JBP/AY**Date of Opening: - **.....**

Name of Tenderer: - M/s. _____

Following items are being submitted as samples: -

<u>S.No.</u>	<u>Code No.</u>	<u>Description</u>	<u>Make /Brand</u>	<u>Qty.</u>	<u>Remarks</u>
1.					
2.					
3.					
4.					
5.					
6.					
7.					
8.					
9.					
10.					
11.					
12.					
13.					
14.					
15.					

Not Required

Signature with seal & date

- Note: -**
1. Only one sample of each item if required shall be submitted as per Annexure 'A'.
 2. The samples should be submitted alongwith the offer (TC-Bid) duly tagged, stamped & signed with Name of Tenderer and Tender Number for proper and exact identification of samples. If the same is not complied, the Tenderer cannot deny the sample identified by us as their sample & the inspection report of the same.
 3. In case of non submission of sample, the Offer may be rejected.

Details of Tendered itemsLimited Tender No. : **LT/04/MM/JBP/AY**

Date of Opening : 28/01/2021

Sl. No.	Code No.	Nomenclature	Unit	Qty.
01	TD 2A 07 V10	Hex Bolt (as per ALIMCO drg.)	Nos.	3000
02	TD 2A 07 V98	Cup Adaptor (as per ALIMCO drg.)	Nos.	2000
03	TD 2A 07 VA5	Bush Swivel (as per ALIMCO drg.)	Nos.	2000
04	TD 2A 07 VB1	Fork (as per ALIMCO drg.)	Nos.	4000
05	TD 2A 07 D03	Strip Folding (as per ALIMCO drg.)	Set	2000
	TD 2A 07 D10			
	TD 2A 07 E01			
	TD 2A 07 E03			
06	TD 2A 07 D04	Link-Right & Left (as per ALIMCO drg.)	Set	2000
	TD 2A 07 E02			
07	TD 2A 07 V02	Plate Bearing (as per ALIMCO drg.)	Nos.	3000
08	TD 2A 07 VB2	Stem (as per ALIMCO drg.)	Nos.	3000
09	TD 2C 51 001	Plate Guard (as per ALIMCO drg.)	Nos.	3000
10	TD 2A 02 D02	Brake Shoe (as per ALIMCO drg.)	Nos.	3000
11	TD 2A 02 D05	Spacer (as per ALIMCO drg.)	Nos.	12000
12	TD 2A 07 A19	Stud (as per ALIMCO drg.)	Nos.	4000
13	TD 1N 61 002	Handle (as per ALIMCO drg.)	Nos.	5000
14	TD 1N 23 009	End Plug (as per ALIMCO drg.)	Nos.	5000
15	TD 4N 34 001	Body (as per ALIMCO drg.)	Nos.	5000

Note:-

- Jigs Fixtures & Dies for manufacturer of the above items required. If any, is to be developed by the party at their own cost. Approval of the sample, if required and commencement of supplies will be required to be done within 30 days after of placement of order or as required by the corporation.
- Jigs, Fixtures & Dies for manufacture of the above items required, if any, is to be developed by the party at their own cost.
- The tentative quantities likely to be covered by Purchase Order are indicated above. The material would be required to be supplied on staggered delivery schedule to be indicated in Purchase Order or as required by the Corporation.
- The total requirement of the above material may vary substantially up or down as per requirement of the Corporation & successful tenderer will be required to arrange the supplies accordingly.
- The tentative monthly requirement will be approx. 1/12th of the quantity indicated above subject to be change by the Corporation which may vary substantially up or down as per requirement of the Corporation & successful tenderer will be required to arrange the supplies accordingly.
- Maximum period required to commence supplies which may normally be not exceeding 30 days from the date of placement of Purchase Order.
- Test reports from Govt./ Accredited Agency/LAB must be provided by supplier with each supply and also the report number must be endorsed in the respective Invoice of the material.
- All the traceable material test certificate must be provided by supplier with each supply and also the material test certificate number must be endorsed in the respective Invoice of the material.

**For: Artificial Limbs Manufacturing Corporation of India,
MM deptt., AAPC-Jabalpur**

(On Letter Head of the Tenderer)

ANNEXURE 'B-1'

Tender No: LT/04/MM/JBP/AY

UNDERTAKING

We hereby confirm that the material quoted/to be supplied is/will be as per ALIMCO Specification & Drawings.

We also hereby undertake to provide requisite Traceable Test Certificate (from OEM/any Govt. Lab/ NABL Accredited lab at the time of each supply and Invoices/Bills will bear relevant Test Certificate, reference no.

Dated:

Authorised Signatory:

Name: -

Designation: -

Seal: -

(On Letter Head of the Tenderer)

Annexure - 'B-2'

Tender No: LT/04/MM/JBP/AY

UNDERTAKING

We hereby undertake to supply the additional quantity of material equal to 100% of the Order quantity at the same rates, terms & conditions if ordered within a period of six months from the date of last supply or during the validity of the Order.

Dated:

Authorised Signatory:

Name: -

Designation: -

Seal: -

(On Letter Head of the Tenderer)

ANNEXURE 'B-3'

Tender No: LT/04/MM/JBP/AY

UNDERTAKING

We hereby undertake that our Firm has not been debarred/ terminated/ blacklisted/ put on holiday to participate in the Tender by any Govt. Institution, PSU, State Govt. or Central Govt. Deptt.

Dated:

Authorised Signatory:

Name: -

Designation: -

Seal: -

(On Letter Head of the Tenderer)

ANNEXURE 'B-4'

Tender No: LT/04/MM/JBP/AY

UNDERTAKING

We hereby undertake that our Offer is valid for acceptance for 90 days from the date of opening of Techno-Commercial Bid (TC-Bid).

Dated:

Authorised Signatory:

Name: -

Designation: -

Seal: -

(On Letter Head of the Tenderer)

ANNEXURE 'B-5'

Tender No: LT/04/MM/JBP/AY

UNDERTAKING

We hereby confirm that payment of basic value within 30 days after supply & acceptance/approval of material or Submission of bill, whichever is later, is acceptable to us. However, the GST portion shall be paid only after submission of proof / self-certified copy of GST Return (GSTR-1) filed online by the tenderer clearly (duly highlighted) showing invoice/ bill number and amount to be submitted to ALIMCO so as to enable the Corporation to avail GST input credit after matching of the GST return and Invoice submitted in the Corporation. In case, non-matching no payment of GST shall be made.

Dated:

Authorised Signatory:

Name: -

Designation: -

Seal: -

Tender Acceptance Letter
(On Letter Head of the Tenderer)

To,

Sub: Acceptance of Terms & Conditions of Tender.

Tender Reference No: -----

Name of Tender / Work: - -----

Dear Sir,

1. I/We have downloaded / obtained the tender document(s) for the above mentioned 'Tender/Work' from the web site(s) namely: As per your advertisement, given in the above mentioned website(s).
2. I/We hereby certify that I / we have read the entire terms and conditions of the tender documents from Page No. ----- to ----- (Including all documents like annexure(s), schedule(s), drawing(s) etc..), which form part of the contract agreement and I / we shall abide hereby by the terms/ conditions/ clauses contained therein.
3. The corrigendum(s) issued from time to time by your department/ organization too have also been taken into consideration, while submitting this acceptance letter.
4. I/We hereby unconditionally accept the tender conditions of above mentioned tender document(s)/corrigendum(s) in its totality/ Entirety.
5. I/We do hereby declare that our Firm has not been blacklisted/ debarred/ terminated/ banned by any Govt. Department/Public Sector Undertaking.
6. I/We certify that all information furnished by our Firm is true & correct and in the event that the information is found to be incorrect/untrue or found violated, then your department/ organization shall without giving any notice or reason therefore or summarily reject the bid or terminate the contract, without prejudice to any other rights or remedy including the forfeiture of the full said earnest money deposit absolutely.

Yours faithfully,

(Signature of the Bidder, with Official Seal)

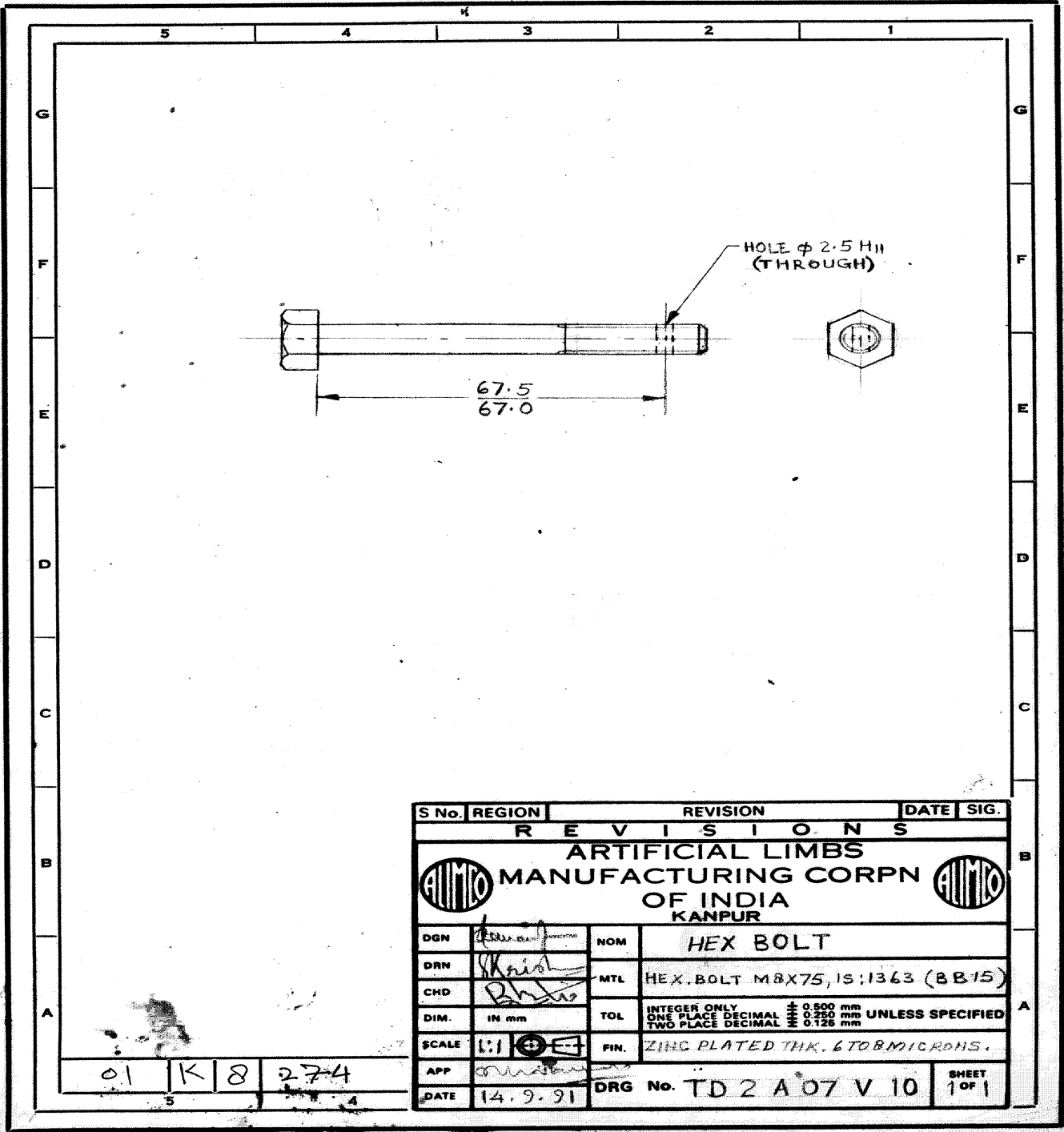

5 4 3 2 1

G G

F F

E E

D D

C C

B B

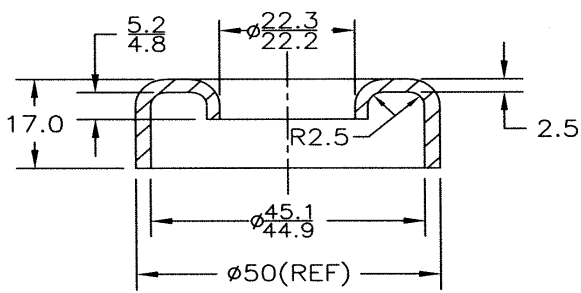

A A

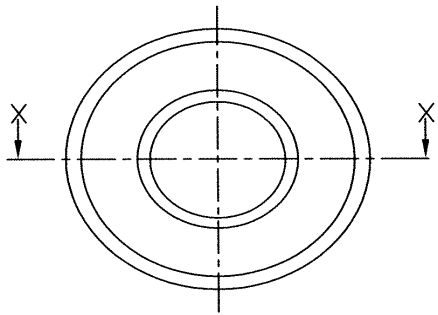

SECTION-XX



- NOTE:--
1. REMOVE SHARP EDGES & CORNERS.
 2. FOR MACHINE DRG REFER DRG No. TD 2 A 07 V A2.
 3. WEIGHT 66gms(APPROX)

5.	DRAWING REDRAWN		17.01.15	<i>Pras</i>
SNo.	REGION	REVISION	DATE	SIGN
R E V I S I O N S				
 ARTIFICIAL LIMBS MANUFACTURING CORPORATION OF INDIA KANPUR 				
DGN		NOM	CUP ADAPTOR	
DRN	<i>Ashish</i>	MTL	SHEET MS CRA Gd'DD' IS:513, THICK 2.5mm (AA33)	
CHD	<i>Pras</i>	TOL	INTEGER ONLY ±0.500 mm ONE PLACE DECIMAL ±0.250 mm TWO PLACE DECIMAL ±0.126 mm	UNLESS SPECIFIED
DIM	IN mm	FIN	---	
SCALE	NTS			
APP	<i>Sa/DO</i>			
DATE	11.04.1981	DRG No:--	TD 2 A 07 V 98	
			SHEET 10F1	

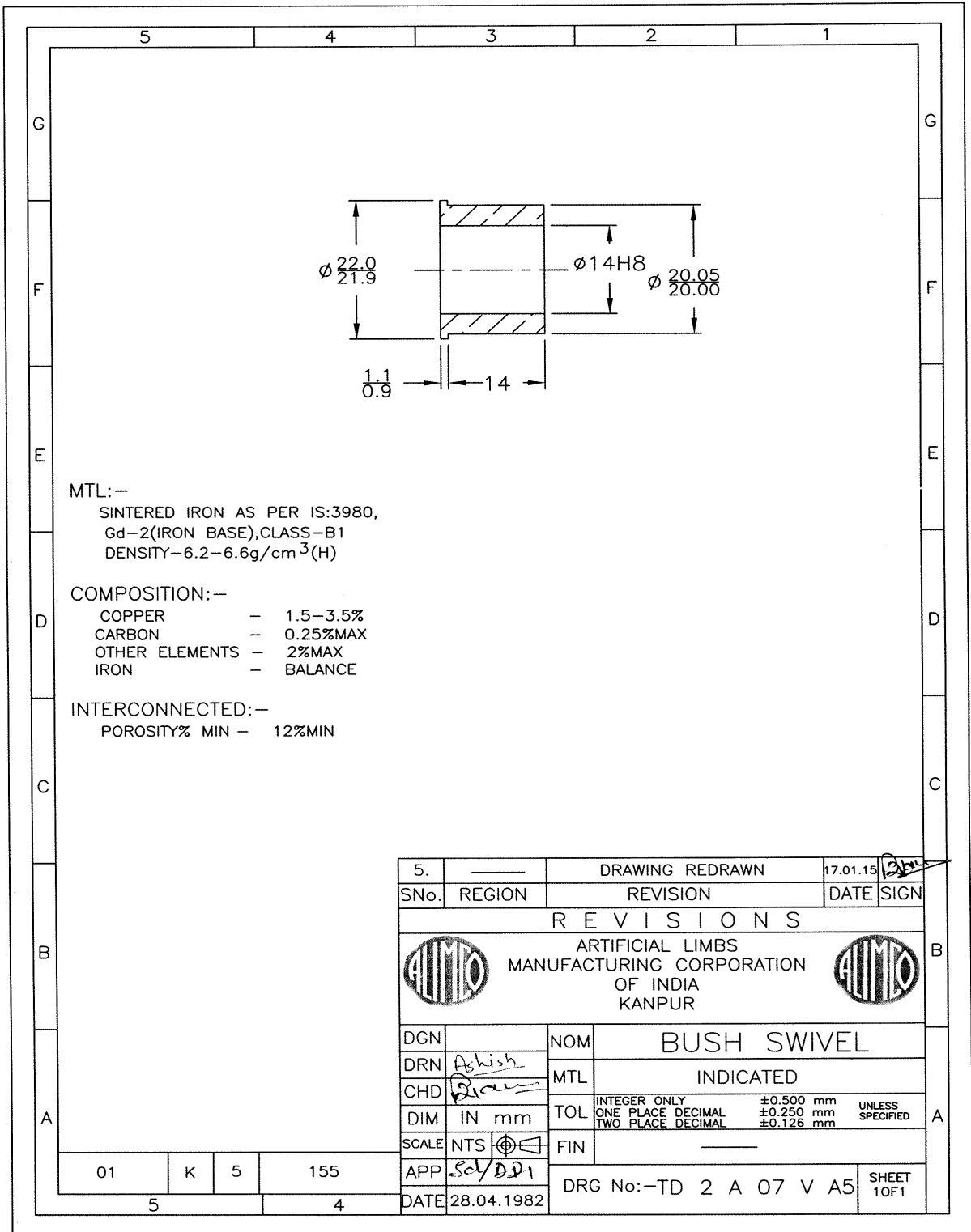

01	K	5	361
5		4	



MTL:—
 SINTERED IRON AS PER IS:3980,
 Gd-2(IRON BASE),CLASS-B1
 DENSITY-6.2-6.6g/cm³(H)

COMPOSITION:—
 COPPER - 1.5-3.5%
 CARBON - 0.25%MAX
 OTHER ELEMENTS - 2%MAX
 IRON - BALANCE

INTERCONNECTED:—
 POROSITY% MIN - 12%MIN

5.	—	DRAWING REDRAWN	17.01.15	<i>[Signature]</i>
SNo.	REGION	REVISION	DATE	SIGN
R E V I S I O N S				
		ARTIFICIAL LIMBS MANUFACTURING CORPORATION OF INDIA KANPUR		
				
DGN		NOM	BUSH SWIVEL	
DRN	<i>Ashish</i>	MTL	INDICATED	
CHD	<i>[Signature]</i>	TOL	INTEGER ONLY ±0.500 mm UNLESS SPECIFIED ONE PLACE DECIMAL ±0.250 mm TWO PLACE DECIMAL ±0.125 mm	
DIM	IN mm	FIN		
SCALE	NTS			
APP	<i>Sol/DD1</i>			
DATE	28.04.1982		DRG No:—TD 2 A 07 V A5	
			SHEET 10F1	

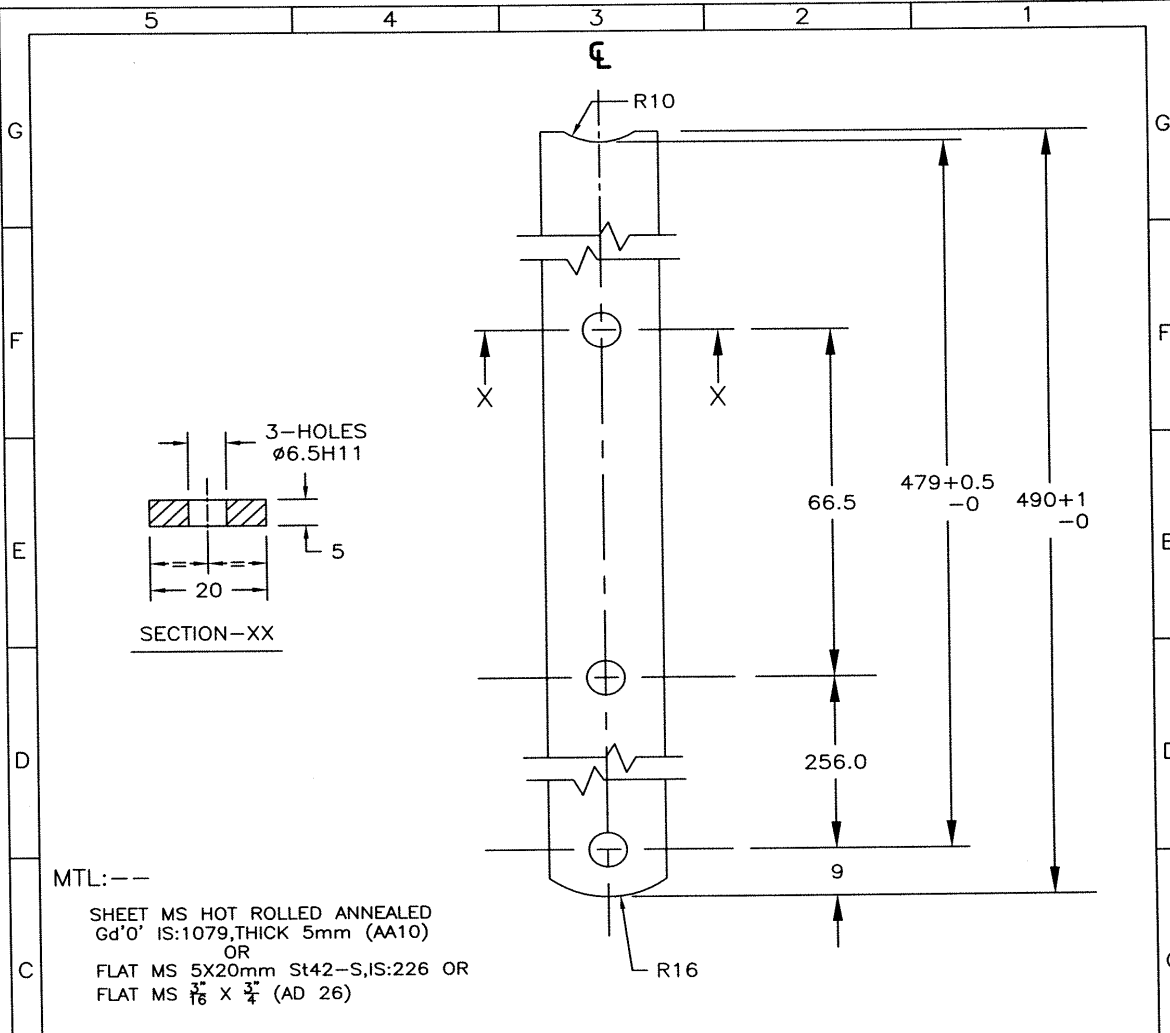

MTL:---

SHEET MS HOT ROLLED ANNEALED
Gd'0' IS:1079, THICK 5mm (AA10)
OR
FLAT MS 5X20mm St42-S, IS:226 OR
FLAT MS 1/8 X 1/4 (AD 26)

NOTE:---

1. REMOVE SHARP EDGES & CORNERS.
2. WEIGHT - 340gms(APPROX)

5.	---	DRAWING REDRAWN	12.02.15	<i>Blas</i>
SNo.	REGION	REVISION	DATE	SIGN
R E V I S I O N S				
ARTIFICIAL LIMBS MANUFACTURING CORPORATION OF INDIA KANPUR				
DGN	<i>Ashish</i>	NOM	STRIP FOLDING RIGHT	
DRN	<i>Blas</i>	MTL	INDICATED	
CHD	<i>Blas</i>	TOL	INTEGER ONLY ±0.500 mm	UNLESS SPECIFIED
DIM	IN mm		ONE PLACE DECIMAL ±0.250 mm	
			TWO PLACE DECIMAL ±0.125 mm	
SCALE	NTS	FIN	BUFF SMOOTH	
APP	<i>S1/001</i>	DRG No.:-	TD 2 A 07 D 03	SHEET 10F1
DATE	23.10.1978			

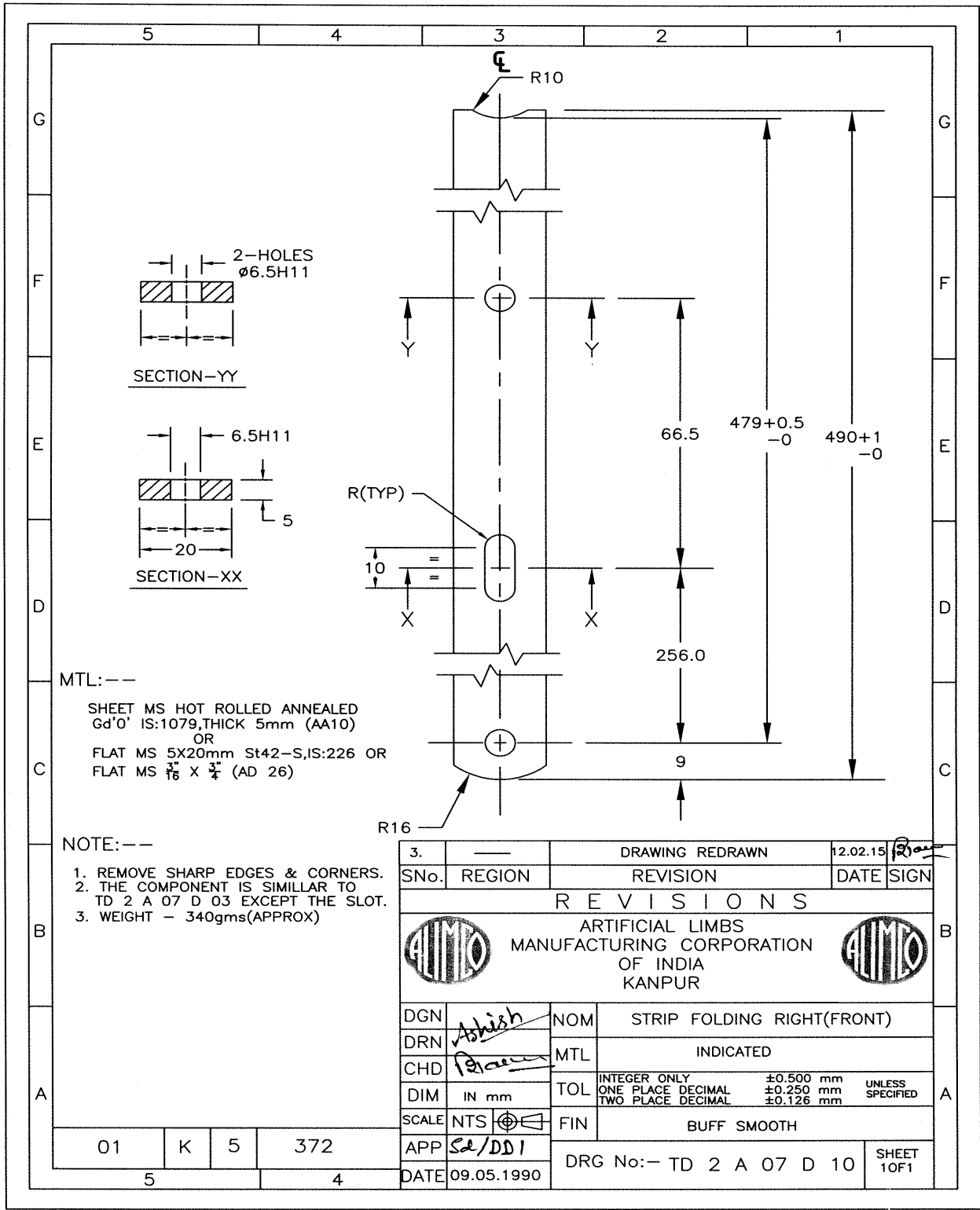

MTL:---

SHEET MS HOT ROLLED ANNEALED
Gd'0' IS:1079, THICK 5mm (AA10)
OR
FLAT MS 5X20mm St42-S, IS:226 OR
FLAT MS 5/16 X 3/4 (AD 26)

NOTE:---

1. REMOVE SHARP EDGES & CORNERS.
2. THE COMPONENT IS SIMILAR TO TD 2 A 07 D 03 EXCEPT THE SLOT.
3. WEIGHT - 340gms(APPROX)

3.	---	DRAWING REDRAWN	12.02.15	<i>[Signature]</i>
SNo.	REGION	REVISION	DATE	SIGN

REVISIONS

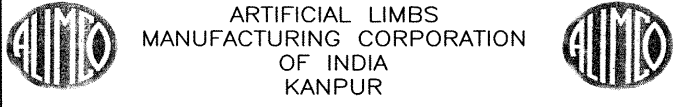

DGN	<i>Abhishek</i>	NOM	STRIP FOLDING RIGHT(FRONT)
DRN	<i>Abhishek</i>	MTL	INDICATED
CHD	<i>Abhishek</i>	TOL	INTEGER ONLY ±0.500 mm ONE PLACE DECIMAL ±0.250 mm TWO PLACE DECIMAL ±0.126 mm UNLESS SPECIFIED
DIM	IN mm	FIN	BUFF SMOOTH
SCALE	NTS $\frac{\phi}{\square}$	APP	<i>Sd/DDI</i>
DATE	09.05.1990	DRG No:-	TD 2 A 07 D 10
			SHEET 10F1

01	K	5	372
5			4

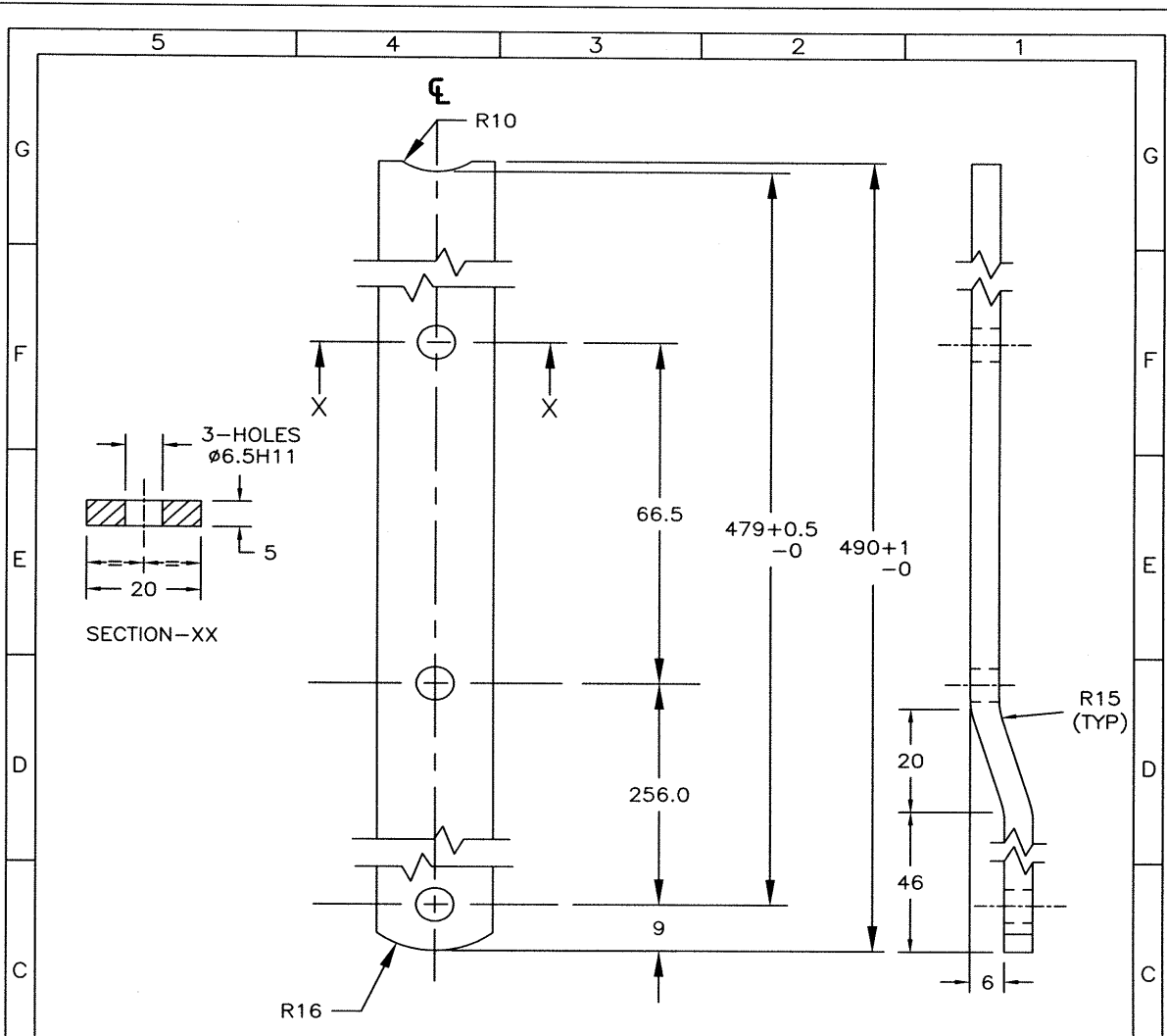



NOTE:--

1. REMOVE SHARP EDGES & CORNERS.
2. WEIGHT - 340gms(APPROX)

MTL:--

SHEET MS HOT ROLLED ANNEALED
Gd'o' IS:1079, THICK 5mm (AA10)
OR
FLAT MS 5X20mm St42-S, IS:226 OR
FLAT MS $\frac{3}{16}$ X $\frac{3}{4}$ (AD 26)

5.	---	DRAWING REDRAWN	12.02.15
SNo.	REGION	REVISION	DATE SIGN
R E V I S I O N S			
 ARTIFICIAL LIMBS MANUFACTURING CORPORATION OF INDIA KANPUR 			
DGN	Ashish	NOM	STRIP FOLDING LEFT
DRN		MTL	INDICATED
CHD	Shau	TOL	INTEGER ONLY ±0.500 mm ONE PLACE DECIMAL ±0.250 mm TWO PLACE DECIMAL ±0.126 mm UNLESS SPECIFIED
DIM	IN mm	FIN	BUFF SMOOTH
SCALE	NTS		
APP	Sd/DDJ		
DATE	23.10.1978	DRG No:-- TD 2 A 07 E 01	SHEET 10F1

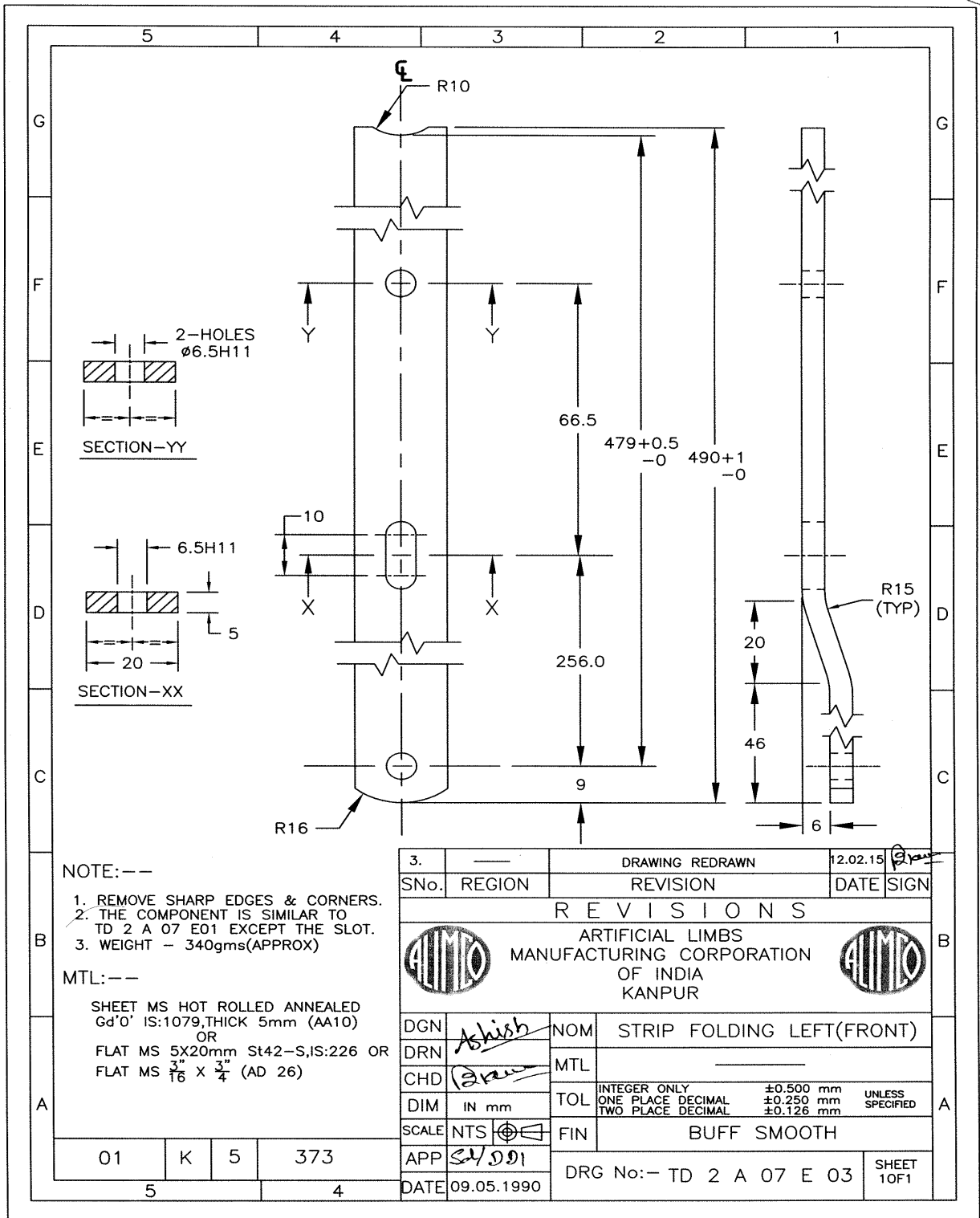

NOTE:---

1. REMOVE SHARP EDGES & CORNERS.
2. THE COMPONENT IS SIMILAR TO TD 2 A 07 E01 EXCEPT THE SLOT.
3. WEIGHT - 340gms(APPROX)

MTL:---

SHEET MS HOT ROLLED ANNEALED
Gd'0' IS:1079, THICK 5mm (AA10)
OR
FLAT MS 5X20mm St42-S, IS:226 OR
FLAT MS $\frac{3}{16}$ X $\frac{3}{4}$ (AD 26)

3.	---	DRAWING REDRAWN	12.02.15	<i>[Signature]</i>
SNo.	REGION	REVISION	DATE	SIGN
REVISIONS				
ARTIFICIAL LIMBS MANUFACTURING CORPORATION OF INDIA KANPUR				
DGN	<i>Ashish</i>	NOM	STRIP FOLDING LEFT(FRONT)	
DRN		MTL		
CHD	<i>[Signature]</i>			
DIM	IN mm	TOL	INTEGER ONLY ±0.500 mm ONE PLACE DECIMAL ±0.250 mm TWO PLACE DECIMAL ±0.126 mm	UNLESS SPECIFIED
SCALE	NTS	FIN	BUFF SMOOTH	
APP	<i>SUDDI</i>	DRG No:--	TD 2 A 07 E 03	SHEET 10F1
DATE	09.05.1990			

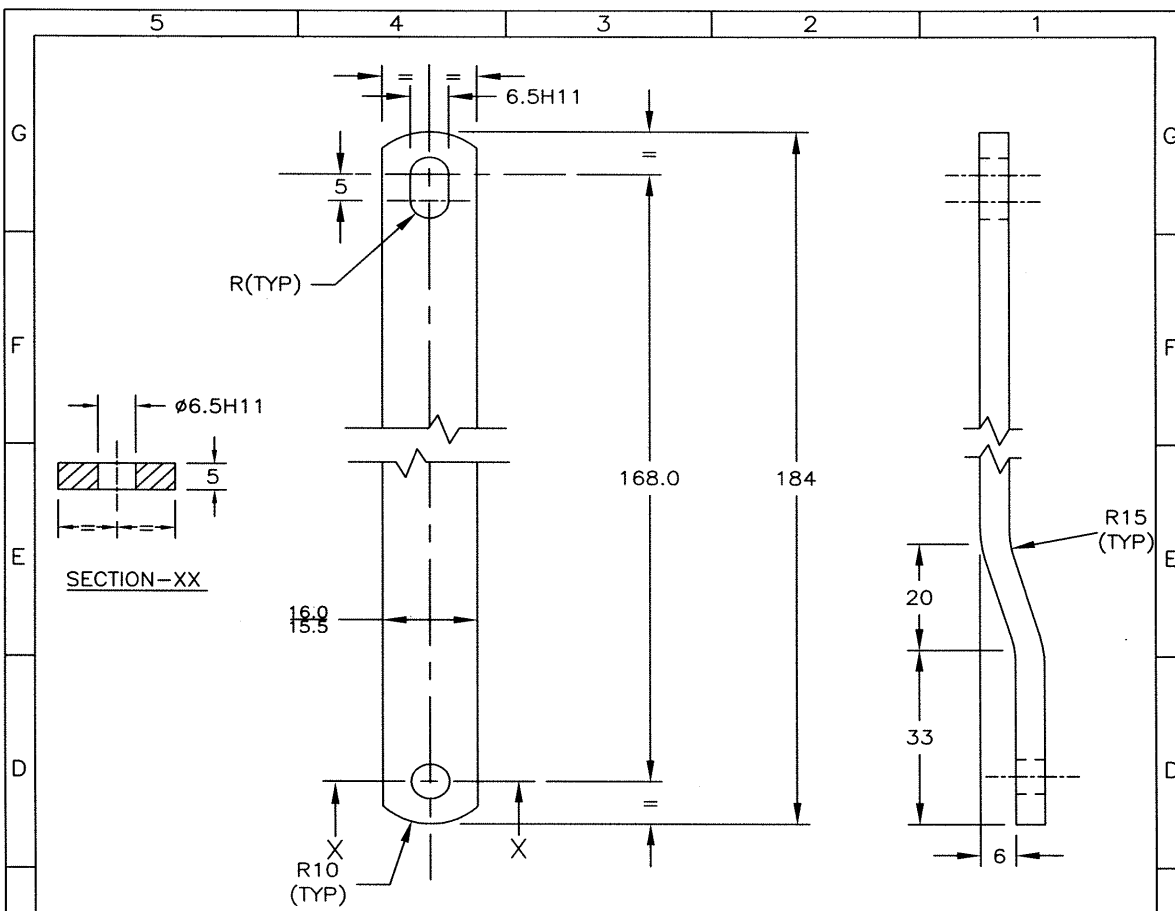

MTL:--

SHEET MS HRA Gd'0' IS:1079,
THICK 5mm (AA10)
OR
FLAT MS 5X16mm St42-S,IS:226 OR
FLAT MS 3/16 X 3/4 (AD 26)

NOTE:--

1. REMOVE SHARP EDGES & CORNERS.
2. WEIGHT - 120gms(APPROX)

9.	---	DRAWING REDRAWN	12.02.15
SNo.	REGION	REVISION	DATE SIGN
R E V I S I O N S			
ARTIFICIAL LIMBS MANUFACTURING CORPORATION OF INDIA KANPUR			
DGN	<i>Abhis</i>	NOM	LINK RIGHT
DRN	<i>Abhis</i>	MTL	INDICATED
CHD	<i>Abhis</i>	TOL	INTEGER ONLY ±0.500 mm ONE PLACE DECIMAL ±0.250 mm TWO PLACE DECIMAL ±0.126 mm UNLESS SPECIFIED
DIM	IN mm	FIN	TD 2 A 07-Ni.Cr. PLATED Gd'2',IS:1068 TD 2 A 08-POWDER COATED COLOUR AS APPD.
SCALE	NTS	DRG No:--	TD 2 A 07 D 04
APP	<i>SyDDI</i>	SHEET	10F1
DATE	23.10.1978		

01	K	5	034
5		4	

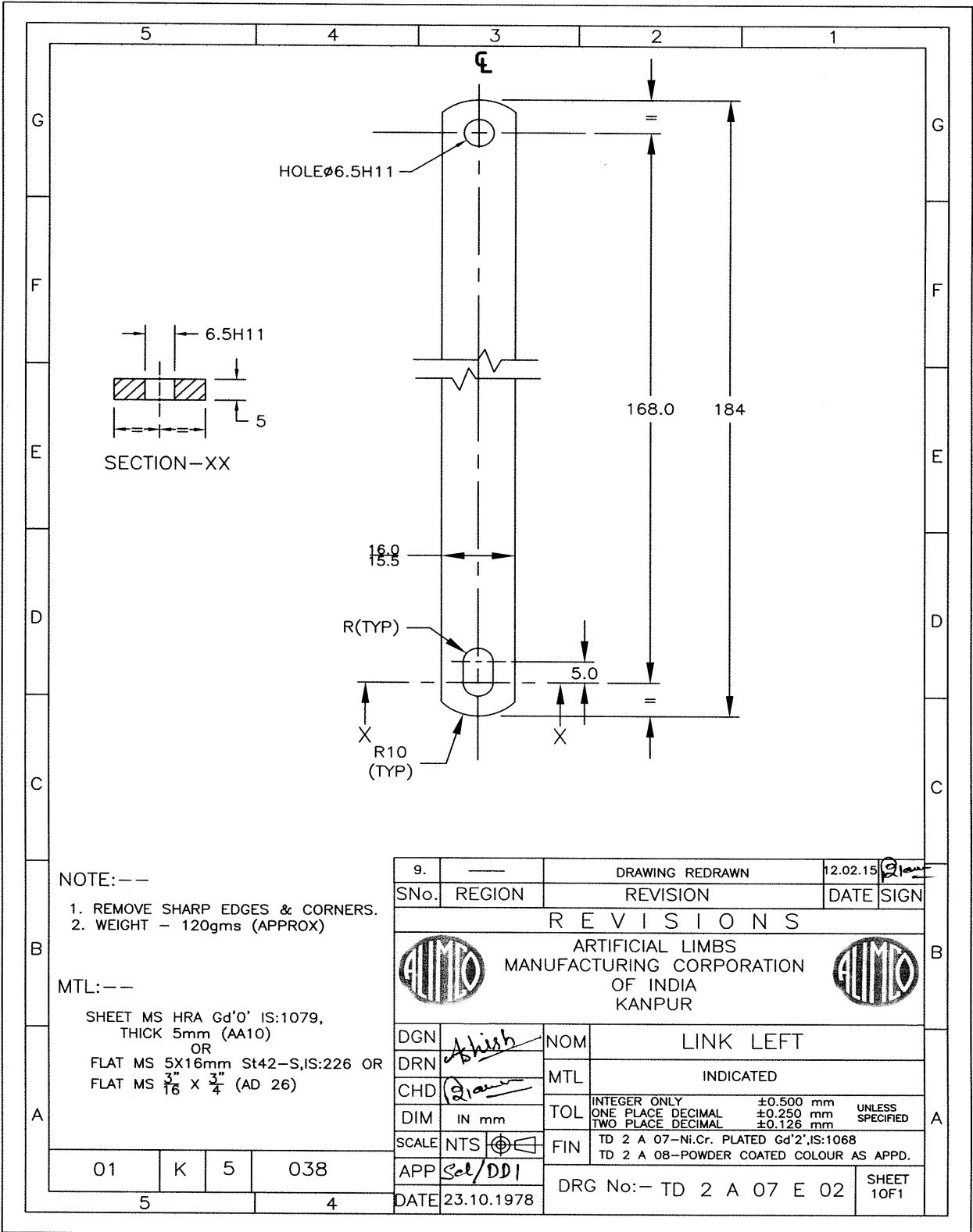

NOTE:--
 1. REMOVE SHARP EDGES & CORNERS.
 2. WEIGHT - 120gms (APPROX)

MTL:--
 SHEET MS HRA Gd'0' IS:1079,
 THICK 5mm (AA10)
 OR
 FLAT MS 5X16mm St42-S,IS:226 OR
 FLAT MS 3/16 X 3/4 (AD 26)

9.	---	DRAWING REDRAWN	12.02.15	<i>[Signature]</i>
SNo.	REGION	REVISION	DATE	SIGN
R E V I S I O N S				
ARTIFICIAL LIMBS MANUFACTURING CORPORATION OF INDIA KANPUR				
DGN	<i>Abhishek</i>	NOM	LINK LEFT	
DRN	<i>[Signature]</i>	MTL	INDICATED	
CHD	<i>[Signature]</i>	TOL	INTEGER ONLY ±0.500 mm ONE PLACE DECIMAL ±0.250 mm TWO PLACE DECIMAL ±0.126 mm UNLESS SPECIFIED	
DIM	IN mm	FIN	TD 2 A 07-Ni.Cr. PLATED Gd'2',IS:1068 TD 2 A 08-POWDER COATED COLOUR AS APPD.	
SCALE	NTS			
APP	<i>Sel/DDI</i>			
DATE	23.10.1978	DRG No:--	TD 2 A 07 E 02	SHEET 10F1

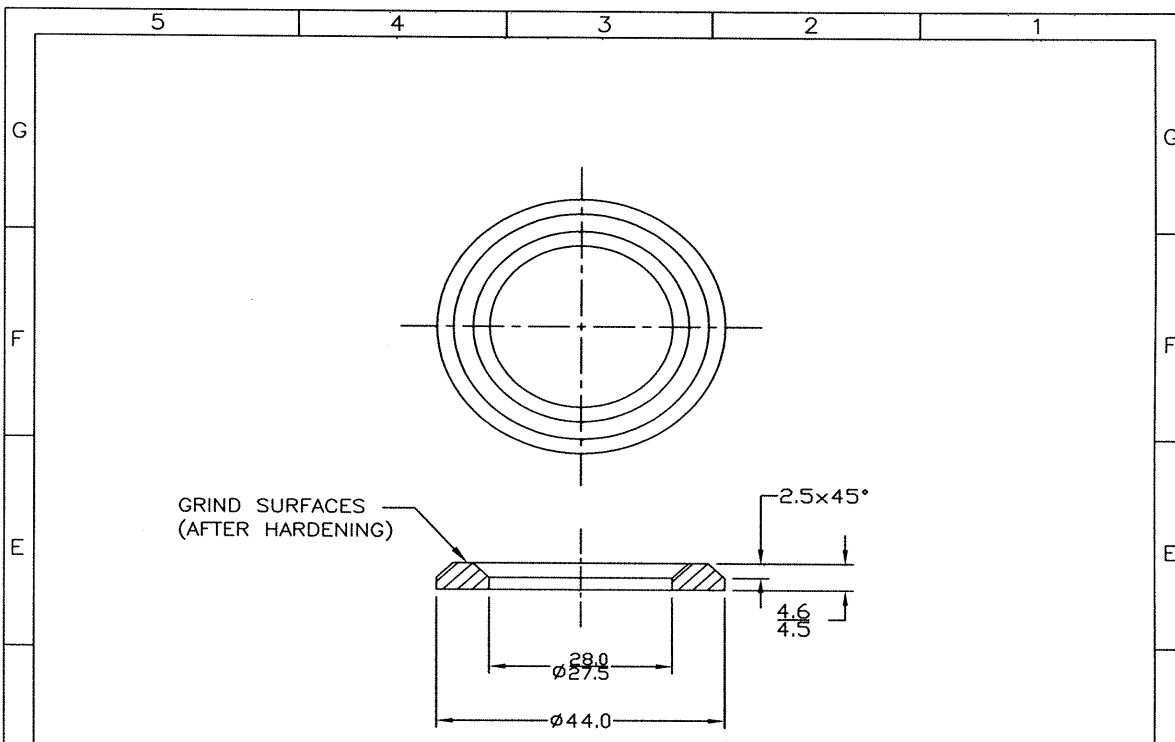

MTL:-
 Rod Carbon Steel C 55 (EN9),
 Ø45mm, IS:1570 (Pt-II) (AH 31)
 OR
 Plate Carbon Steel C 55 (EN9),
 Thick 5mm, IS:1570 (Pt-II) (AH 36)

NOTE:-
 1.Hardened & Tempered -
 Hardness 35-40 HRC.
 2.Weight 30 TO 35gms.

TOLERANCE:-

DEVIATION FOR NON TOLERANCED DIMENSIONS (ISI:2102 MEDIUM)	
DIAMETER & LENGTHS BETWEEN	LENGTH IN MM OF SHORTER SIDE OF ANGLE UPTO & INCL.
0.5 up to 6 ±0.1	Up to 10 ±1°00'
Over 6 up to 30 ±0.2	Over 10 upto 50 ±0°30'
Over 30 up to 120 ±0.3	Over 50 upto 120 ±0°20'
Over 120 up to 315 ±0.5	Over 120 upto 400 ±0°10'
Over 315 up to 1000 ±0.8	
Over 1000 up to 2000 ±1.2	
Over 2000 up to 4000 ±2.0	

MACHINING FINISH IN MICRONS
 ▽ 8 - 25 ▽▽ 1.6 - 8 ▽▽▽ 0.025 - 1.6 ▽▽▽▽ <0.025

THIS DRAWINGS AND SPECIFICATION ARE THE PROPERTY OF ALIMCO AND SHALL NOT BE REPRODUCED OR COPIED WITHOUT PRIOR PERMISSION.

5	D - 5	MTL AH 31 OR AH 36 WERE AH 13 OR AL 11	28.10.17
4	---	DRAWING REDRAWN	07.09.16
SNo.	REGION	REVISION	DATE SIGN
REVISIONS			
ARTIFICIAL LIMBS MANUFACTURING CORPORATION OF INDIA KANPUR			
DGN	DRN	NOM	PLATE BEARING UPPER
CHD	DIM	MTL	INDICATED
SCALE	APP	HEAT TREATMENT	INDICATED
DATE	APP	SURFACE TREATMENT	MACHINED & GROUND
5	4	DRG No:- TD 2 A 07 V 02	REV 5 SHEET 1 OF 1

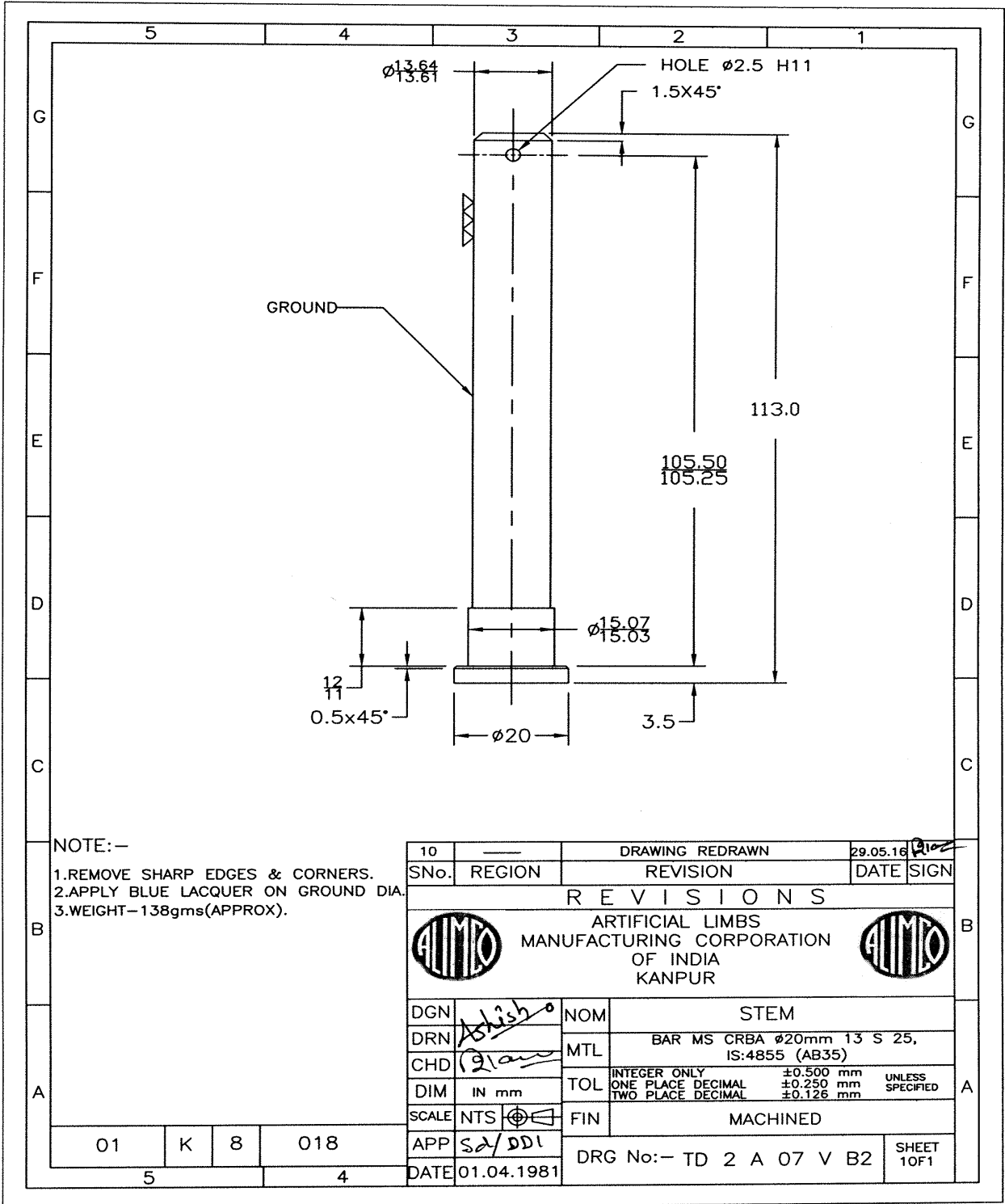

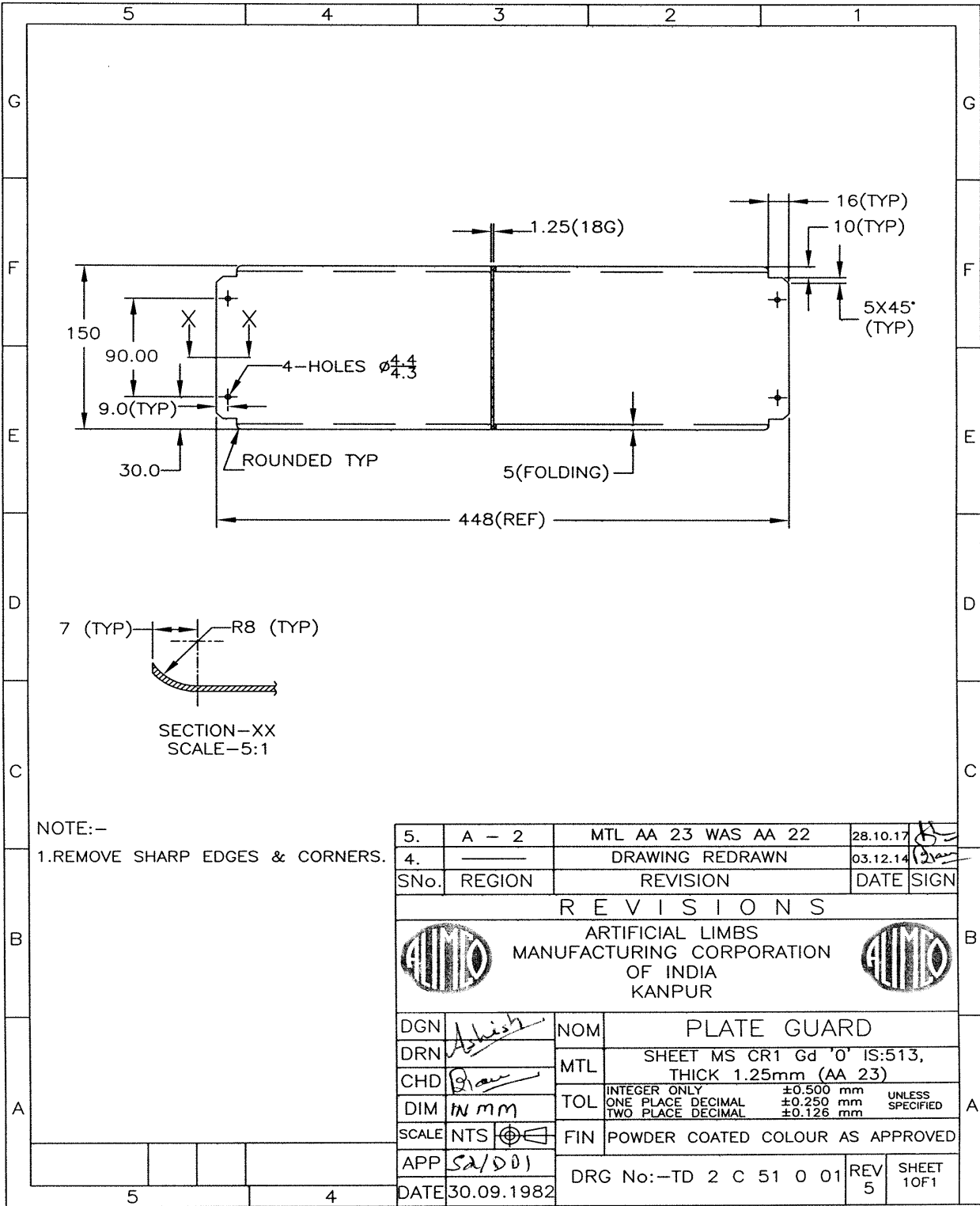

NOTE:-
1. REMOVE SHARP EDGES & CORNERS.

5.	A - 2	MTL AA 23 WAS AA 22	28.10.17	<i>[Signature]</i>
4.		DRAWING REDRAWN	03.12.14	<i>[Signature]</i>
SNo.	REGION	REVISION	DATE	SIGN
R E V I S I O N S				
		ARTIFICIAL LIMBS MANUFACTURING CORPORATION OF INDIA KANPUR		
DGN	<i>Ashish</i>	NOM	PLATE GUARD	
DRN	<i>[Signature]</i>	MTL	SHEET MS CR1 Gd '0' IS:513, THICK 1.25mm (AA 23)	
CHD	<i>[Signature]</i>	TOL	INTEGER ONLY ±0.500 mm ONE PLACE DECIMAL ±0.250 mm UNLESS SPECIFIED TWO PLACE DECIMAL ±0.126 mm	
DIM	<i>IN MM</i>	FIN	POWDER COATED COLOUR AS APPROVED	
SCALE	NTS	APP	DRG No:--TD 2 C 51 0 01	
APP	<i>Sa/DDJ</i>	DATE		
DATE	30.09.1982			

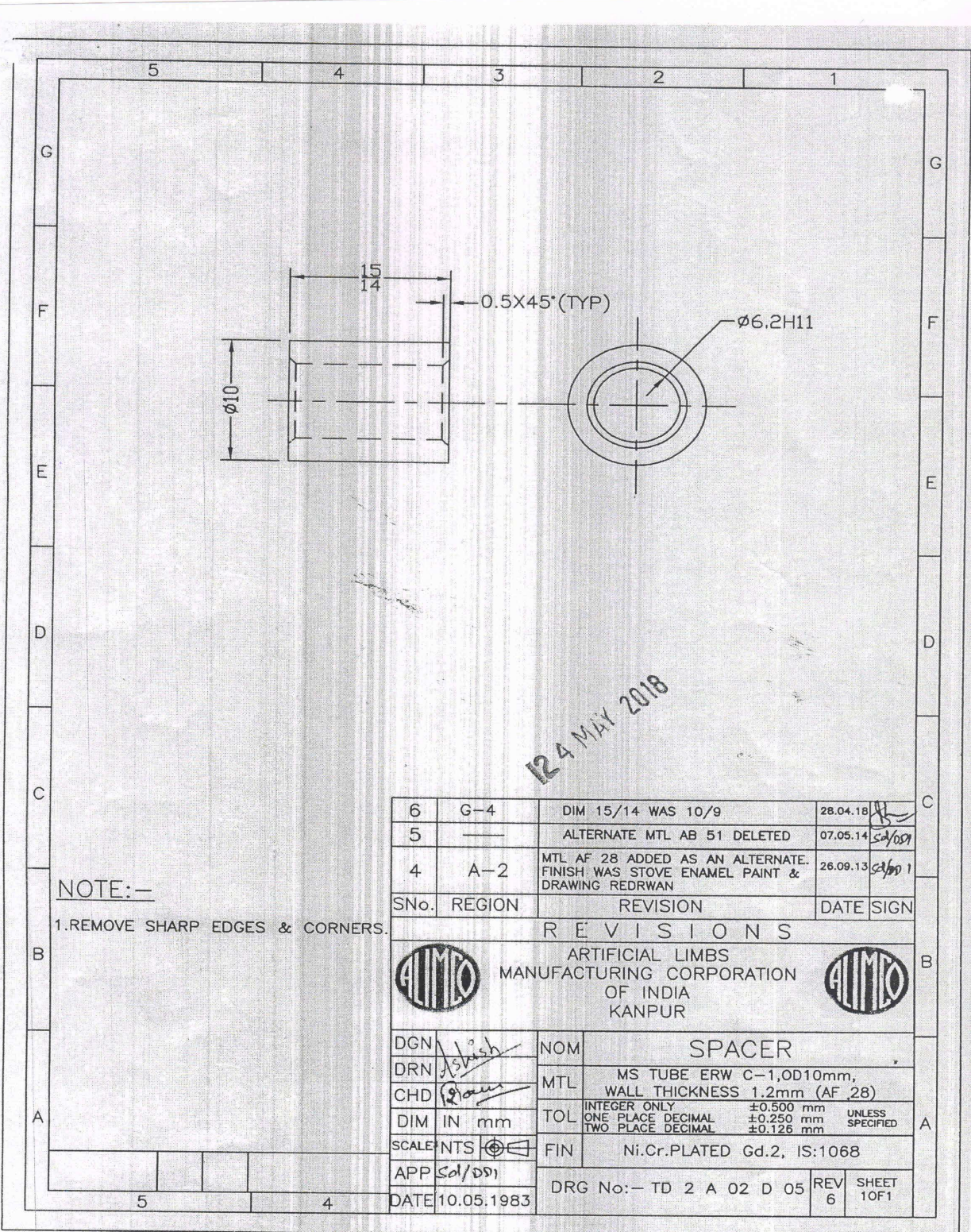

124 MAY 2018

NOTE:—

1. REMOVE SHARP EDGES & CORNERS.

6	G-4	DIM 15/14 WAS 10/9	28.04.18	<i>[Signature]</i>
5	—	ALTERNATE MTL AB 51 DELETED	07.05.14	<i>[Signature]</i>
4	A-2	MTL AF 28 ADDED AS AN ALTERNATE. FINISH WAS STOVE ENAMEL PAINT & DRAWING REDRAWN	26.09.13	<i>[Signature]</i>
SNo.	REGION	REVISION	DATE	SIGN

REVISIONS

ARTIFICIAL LIMBS MANUFACTURING CORPORATION OF INDIA KANPUR

DGN	<i>[Signature]</i>	NOM	SPACER	
DRN	<i>[Signature]</i>	MTL	MS TUBE ERW C-1.0D10mm, WALL THICKNESS 1.2mm (AF 28)	
CHD	<i>[Signature]</i>	TOL	INTEGER ONLY ±0.500 mm ONE PLACE DECIMAL ±0.250 mm TWO PLACE DECIMAL ±0.125 mm	UNLESS SPECIFIED
DIM	IN mm	FIN	Ni.Cr.PLATED Gd.2, IS:1068	
SCALE	NTS			
APP	<i>[Signature]</i>	DATE	10.05.1983	
		DRG No:—	TD 2 A 02 D 05	REV 6 SHEET 10F1

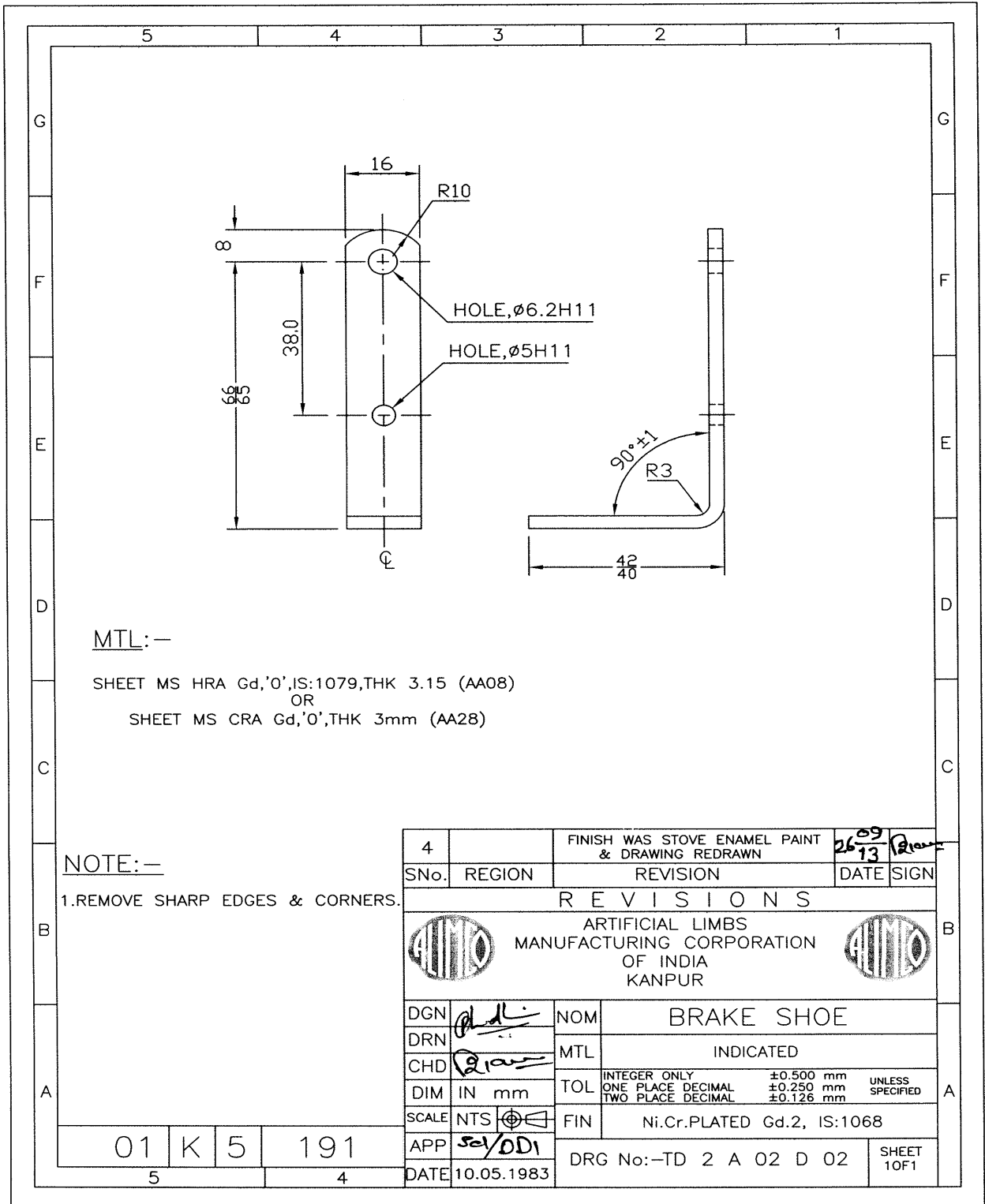

MTL:—

SHEET MS HRA Gd,'0',IS:1079,THK 3.15 (AA08)
OR
SHEET MS CRA Gd,'0',THK 3mm (AA28)

NOTE:—

1.REMOVE SHARP EDGES & CORNERS.

4		FINISH WAS STOVE ENAMEL PAINT & DRAWING REDRAWN	26/09/13	26/09/13
SNo.	REGION	REVISION	DATE	SIGN
REVISIONS				
		ARTIFICIAL LIMBS MANUFACTURING CORPORATION OF INDIA KANPUR		
DGN	<i>[Signature]</i>	NOM	BRAKE SHOE	
DRN	<i>[Signature]</i>	MTL	INDICATED	
CHD	<i>[Signature]</i>	TOL	INTEGER ONLY ±0.500 mm UNLESS SPECIFIED ONE PLACE DECIMAL ±0.250 mm TWO PLACE DECIMAL ±0.125 mm	
DIM	IN mm	FIN	Ni.Cr.PLATED Gd.2, IS:1068	
SCALE	NTS	APP	DRG No:—TD 2 A 02 D 02	SHEET 10F1
01	K 5	191	DATE 10.05.1983	

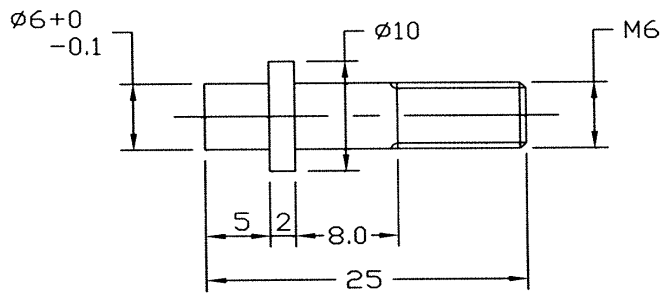

NOTE:---

1. REMOVE SHARP EDGES & CORNERS.
2. WEIGHT - 6gms(APPROX)

6.	A - 1	FINISH - Ni.Cr. PLATED DELETED	28.10.17	<i>[Signature]</i>
5.		DRAWING REDRAWN	14.01.15	<i>[Signature]</i>
SNo.	REGION	REVISION	DATE	SIGN

REVISIONS

ARTIFICIAL LIMBS MANUFACTURING CORPORATION OF INDIA KANPUR

DGN	<i>[Signature]</i>	NOM	STUD	
DRN	<i>[Signature]</i>	MTL	BAR MS CRBA ϕ 10mm, (11 C 10 S 25) AS PER IS:9550 (AB51)	
CHD	<i>[Signature]</i>	TOL	INTEGER ONLY ± 0.500 mm ONE PLACE DECIMAL ± 0.250 mm TWO PLACE DECIMAL ± 0.125 mm	UNLESS SPECIFIED
DIM	IN mm	FIN		
SCALE	NTS ϕ	APP	<i>[Signature]</i>	
DATE	26.05.1978	DRG No:--TD 2 A 07 A 19	REV 6	SHEET 10F1

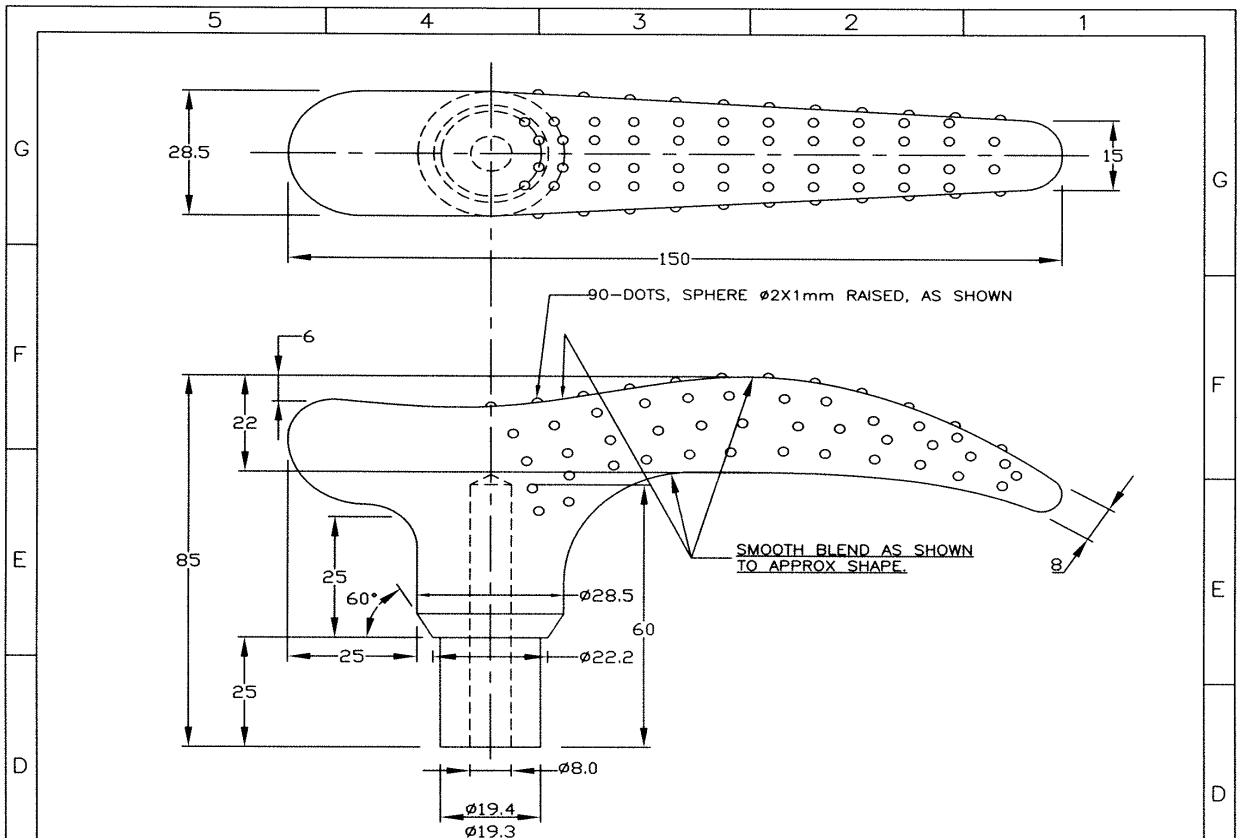

MTL:-
 AW 69:- GRANULES REPOL POLYPROPYLENE
 B 030MG OF RELIANCE MAKE,
 COLOUR-LIGHT BROWN OR SKIN SHADE,
 IS:10910
 OR
 AW 96:- GRANULES POLYPROPYLENE
 NATURAL COLOUR COMMERCIAL
 IS:7078

- NOTE:-
1. ALL DIMS. ARE FOR REF. ONLY.
 2. FINISH SMOOTH FOR PARTING LINE AND INJECTION POINT.
 3. MOULDING TO BE FREE FROM ALL MOULDING DEFECTS LIKE BLOW HOLES, INCOMPLETE MOULDING ETC.
 4. WEIGHT- 85 TO 90 gms.

6	C - 5	MTL AW 96 ADDED AS AN ALTERNATE	04.09.17	<i>[Signature]</i>
SNo.	REGION	REVISION	DATE	SIGN

REVISIONS



DGN	<i>[Signature]</i>	NOM	HANDLE
DRN	<i>[Signature]</i>	MTL	INDICATED
CHD	<i>[Signature]</i>	TOL	INTEGER ONLY ± 0.500 mm ONE PLACE DECIMAL ± 0.250 mm TWO PLACE DECIMAL ± 0.126 mm UNLESS SPECIFIED
DIM	INmm	FIN	MOULDED
SCALE	NTS ϕ	DRG No:-	TD 1 N 61 0 02
APP	<i>[Signature]</i>	DATE	24.06.1988
			SHEET 1 OF 1

5

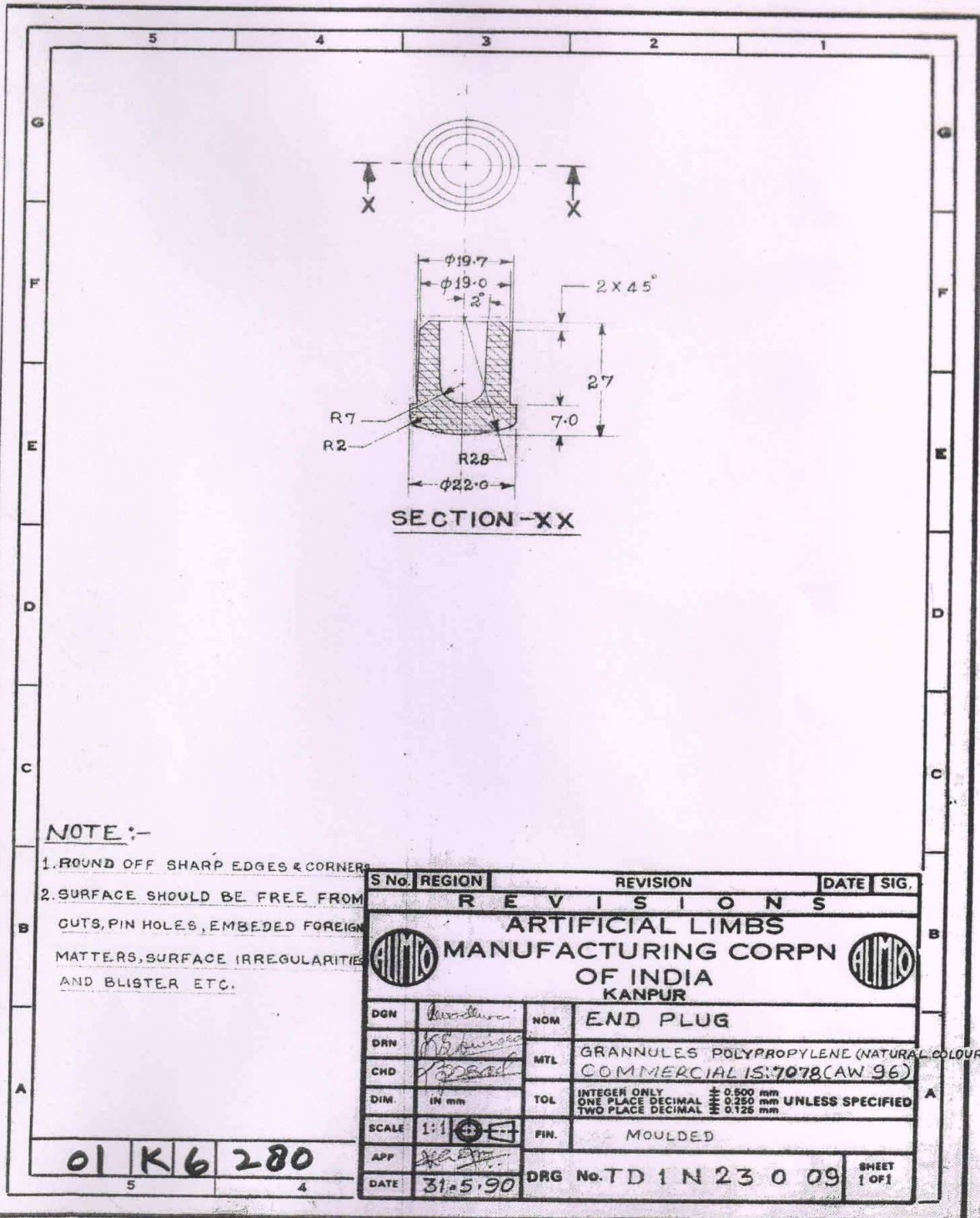

NOTE :-

1. ROUND OFF SHARP EDGES & CORNERS
2. SURFACE SHOULD BE FREE FROM CUTS, PIN HOLES, EMBEDDED FOREIGN MATTERS, SURFACE IRREGULARITIES AND BLISTER ETC.

S No.	REGION	REVISION	DATE	SIG.
REVISIONS				
ARTIFICIAL LIMBS MANUFACTURING CORPN OF INDIA KANPUR				
DGN	<i>[Signature]</i>	NOM	END PLUG	
DRN	<i>[Signature]</i>	MTL	GRANULES POLYPROPYLENE (NATURAL COLOUR)	
CHD	<i>[Signature]</i>		COMMERCIAL IS: 7078(CAW 96)	
DIM.	IN mm	TOL	INTEGER ONLY ± 0.500 mm ONE PLACE DECIMAL ± 0.250 mm TWO PLACE DECIMAL ± 0.125 mm UNLESS SPECIFIED	
SCALE	1:1	FIN.	MOULDED	
APP	<i>[Signature]</i>	DRG No.	TD 1 N 23 0 09	SHEET 1 OF 1
DATE	31.5.90			

01 K 6 280

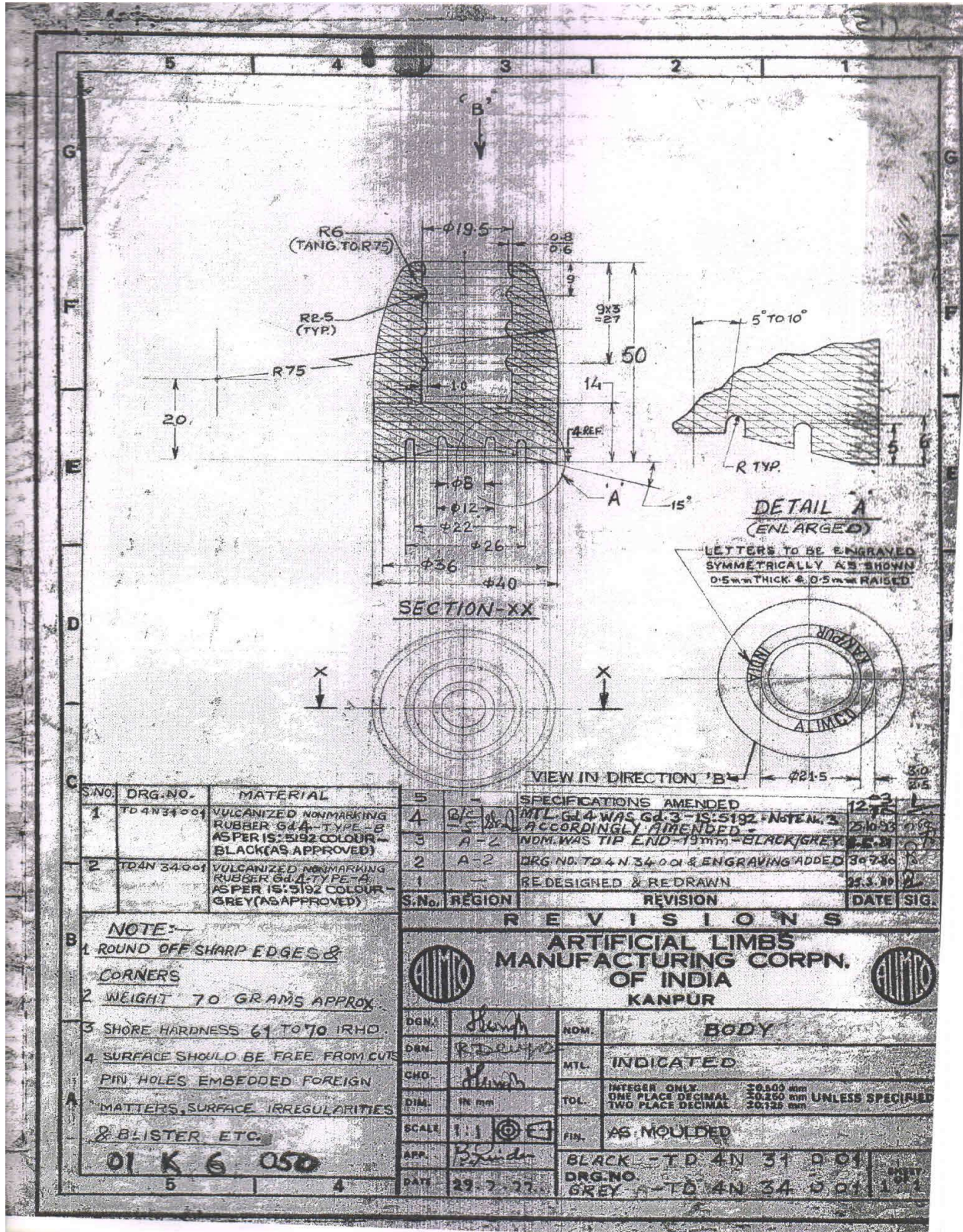

S.NO.	DRG.NO.	MATERIAL
1	TD 4N 34 0 0 1	VULCANIZED NONMARKING RUBBER G4A-TYPE-B AS PER IS: 5192 COLOUR BLACK (AS APPROVED)
2	TD 4N 34 0 0 1	VULCANIZED NONMARKING RUBBER G4A-TYPE-A AS PER IS: 5192 COLOUR GREY (AS APPROVED)

S.No.	REGION	REVISION	DATE	SIG.
5		SPECIFICATIONS AMENDED	12.7.72	
4		MTL G4A WAS Gd. 3 - IS: 5192 - NOTE N. 3 ACCORDINGLY AMENDED	23.10.72	
3		NDM WAS TIP END - 19mm - BLACK/GREY	2.12.72	
2		DRG NO. TD 4N 34 0 0 1 & ENGRAVING ADDED	30.7.73	
1		RE DESIGNED & REDRAWN	22.3.70	

NOTE:-

1. ROUND OFF SHARP EDGES & CORNERS
2. WEIGHT 70 GRAMS APPROX.
3. SHORE HARDNESS 61 TO 70 IRHD.
4. SURFACE SHOULD BE FREE FROM CUTS PIN HOLES EMBEDDED FOREIGN MATTERS, SURFACE IRREGULARITIES & BLISTER ETC.

01 K 6 050

REVISIONS			
ARTIFICIAL LIMBS MANUFACTURING CORPN. OF INDIA KANPUR			
DGN.	SKM	NOM.	BODY
DRW.	R. D. S.	MTL.	INDICATED
CHKD.	SKM	TOL.	INTEGER ONLY 20.000 mm ONE PLACE DECIMAL 20.100 mm TWO PLACE DECIMAL 20.120 mm UNLESS SPECIFIED
DIM.	IN mm	FIN.	AS MOULDED
SCALE	1:1		
APP.	B. S.		
DATE	29.7.73		
			BLACK - TD 4N 34 0 0 1 DRG. NO. GREY - TD 4N 34 0 0 1