

भारतीय कृत्रिम अंग निर्माण निगम

(भारत सरकार का उपक्रम)

जी.टी. रोड, कानपुर-209217

सम्पर्क करें- www.alimco.in

फोन- 0512-2770176, फैक्स- 0512-2770617

टॉल फ्री नं.: 180 01805129



ALIMCO



ISO : 9001 : 2015

ARTIFICIAL LIMBS MANUFACTURING CORPORATION OF INDIA

(A Government of India Undertaking)

G.T. Road, Kanpur-209217

Visit us: www.alimco.in

Phone- 0512-2770176, Fax- 0512-2770617

TOLLFREE NO. 18001805129



ALIMCO



ISO : 9001 : 2015

OPEN TENDER NOTICE NO. PT/OT/08 to 09/AW

Online Bids (Technical & Price Bid) are invited for supply of item as per details indicated below:

Sl No.	Tender No.	Category of Items	Qty.	Approx. Value (Rs.)	EMD Amount (Rs.)	Date of submission of EMD, tender fee, & Bid Submission	Due Date of Opening
01	PT/OT/08/AW	Belt Sander Machine for Prosthetics & Orthotics use	01 Set	1350000/-	34000/-	18.01.19	21.01.19
02	PT/OT/09/AW	CNC Tube Bending Machine its Software	01 Set	2,80,00,000/-	500,000/-	24.01.19	25.01.19

Interested Tenderers may download the tender document from ALIMCO website www.alimco.in (for reference only) and CPPP website: <https://eprocure.gov.in/eprocure/app>. Tender Fee of Rs 560/- to be submitted in the form of Demand Draft in favour of ALIMCO, payable at Kanpur. All SSI / MSE Vendor are exempted from Tender Cost producing/submitted Valid Udyog Aadhaar Memorandum only.

Tenderers are requested to submit their Offers/ Bids through **E-Tendering Process** only on <https://eprocure.gov.in/eprocure/app> and send the Original Demand Draft against Tender fee and EMD to reach ALIMCO office latest by date as mentioned in the above table. The Technical Bid will be opened at **15:30 hrs.** on the **due date as indicated above**. ALIMCO reserves the right to reject any or all requests/Offer without assigning any reason.

For ALIMCO - Sr. Manager (SP & C)

खुली निविदा सूचना सं० पीटी/ओटी/०८ से ०९/ए डब्ल्यू

नीचे दिये गए विवरण के अनुसार निम्नलिखित मदों की आपूर्ति हेतु ऑनलाइन निविदाएं (टेक्नीकल एवं प्राइस बिड) आमंत्रित की जाती हैं:

क्र. सं.	निविदा सं०	वस्तुओं की श्रेणी	मात्रा	अनुमानित मूल्य (रु.)	ईएमडी राशि (रु.)	ईएमडी, निविदा मूल्य एवं निविदा जमा करने की तिथि	निविदा खुलने की तिथि
01	पीटी/ओटी/०८/ए डब्ल्यू	प्रोस्थेटिक्स व ऑर्थोटिक्स प्रयोग हेतु बेल्ट सैंडर मशीन	०१ सेट	1350000/-	34000/-	18.01.19	21.01.19
02	पीटी/ओटी/०९/ए डब्ल्यू	सीएनसी ट्यूब बेंडिंग मशीन व इसका साफ्टवेयर	०१ सेट	2,80,00,000/-	500,000/-	24.01.19	25.01.19

इच्छुक निविदादाता एलिम्को की वेबसाइट www.alimco.in (केवल संदर्भ के लिए) व सीपीपीपी वेबसाइट <https://eprocure.gov.in/eprocure/app> से निविदा दस्तावेज डाउनलोड कर सकते हैं। निविदा शुल्क रु. 560/- डिमांड ड्राफ्ट एलिम्को के पक्ष देय, कानपुर के रूप में जमा कराना होगा। सभी एसएसआई/एमएसई विक्रेताओं को वैध उद्योग आधार ज्ञापन प्रस्तुत/जमा करने पर निविदा शुल्क से छूट प्राप्त है।

निविदाकर्ताओं से अनुरोध है कि वे ऑन लाईन ई-टेंडरिंग प्रक्रिया के माध्यम से अपने प्रस्ताव/बिड <https://eprocure.gov.in/eprocure/app> पर जमा करें और निविदा शुल्क एवं ईएमडी के विरुद्ध मूल डिमांड ड्राफ्ट ऊपर तालिका में अंकित तिथि के अनुसार एलिम्को कार्यालय में जमा करें। तकनीकी निविदा ऊपर दी गई देय तिथि को 15.30 बजे खोली जायेगी। एलिम्को को किसी भी या सभी आवेदनों/प्रस्ताव को बिना कारण बताये निरस्त करने का अधिकार है।
वास्ते-एलिम्को, वरिष्ठ प्रबंधक (एसपी एंड सी)



ALIMCO

**Artificial Limbs Manufacturing
Corporation of India**
(A GOVERNMENT OF INDIA UNDERTAKING)
G.T. ROAD, KANPUR-U.P.
209217

TENDER NO. PT/OT/09/AW
DATE – 12.12.2018

TENDER DOCUMENTS

FOR

“CNC TUBE BENDING MACHINE & ITS SOFTWARE”
(On Turnkey Basis)

Dear Sir,

1. Online tenders are invited for the supply, installation & Commissioning of **“CNC Tube Bending Machine Its Software” (On Turnkey Basis)** to the following destination conforming strictly to ALIMCO Specifications enclosed at Annexure-A, against Purchase Orders to be placed on the successful Tenderer within specified period as per Purchase Order. The specific conditions of supply are enclosed at Annexure-D. **Manual bids shall not be accepted.**

Artificial Limbs Manufacturing Corporation of India
G.T. ROAD, Kanpur-209217 (U.P.)

Qty – 01 Set.

2. The specification of **“CNC Tube Bending Machine Its Software” (On Turnkey Basis)** and a tentative quantity likely to be covered by Purchase Order is indicated in the **ANNEXURE- ‘A’**. The machine/item/equipment would be required to be supplied as per the delivery schedule specified in our Purchase Order or as indicated in the tender.

Sr. No.	Description	Qty.	Estimated Cost (in Rs.)	EMD (in Rs.)
1.	CNC Tube Bending Machine Its Software	01 Set	2,80,00,000/-	500,000/-

3. **Tender documents may be downloaded from ALIMCO website www.alimco.in (for reference only) and CPPP website <https://eprocure.gov.in/eprocure/app> as per the schedule as given in CRITICAL DATE SHEET as under.**

CRITICAL DATE SHEET

Published Date	28.12.2018 (10:00 AM)
Bid Document Download Start Date	28.12.2018 (10:00 AM)
Bid Submission Start Date	28.12.2018 (10:00 AM)
Bid Submission End Date	18.01.2019 (02:00 PM)
Bid Opening Date	21.01.2019 (3:30 PM)

Bids shall be submitted online only at CPPP website: <https://eprocure.gov.in/eprocure/app>.

Tenderer/Contractors are advised to follow the instructions provided in the ‘Instructions to the Contractors/Tenderer for the e-submission of the bids online through the Central Public Procurement Portal for e Procurement at <https://eprocure.gov.in/eprocure/app> .

Bid documents may be scanned with 100 dpi with black and white option which helps in reducing size of the scanned document.

Part I ('TC' BID):

The tenderers are requested to submit the scan copy of following details/documents in their 'TC'-Bid.

Mandatory / Pre-Qualification Criteria):-

- i) Submit, scan copy of DD for Rs. 560/- (GST @ 12% Included) in favour of ALIMCO, payable at Kanpur towards cost of Tender documents, if down-loaded from the website of the Corporation/CPPP and original copy of the same should reach to the office of Senior Manager (SP&C), Artificial Limbs Manufacturing Corporation of India, G. T. Road, Kanpur – 209 217 on or before **dated 18.01.2019** (All SSI units/ MSE Vendors are exempted from Tender Cost).
- ii) **Earnest Money:-**Submit scan copy of Demand Draft or Pay Order or Bankers Cheque for Rs. 5,00,000/- in favour of **ALIMCO**, payable at **KANPUR** as Earnest Money Deposit along with 'TC' BID and original copy of the same should reach to the office of Senior Manager (SP&C), Artificial Limbs Manufacturing Corporation of India, G. T. Road, Kanpur – 209 217 on or before **dated 18.01.2019**.Exemption from Earnest Money Deposit (EMD) will be allowed to all SSI units/ Micro & small enterprises (MSE) on submission of valid Udyog adhaar memorandum (UAM) only (no other document shall exempt units from EMD) against tender for the items/nature of business/ type of services specified there in the UAM.
- iii) The person signing the bid should be duly authorised representative of the firm/company whose signature should be verified and certificate of authority should be submitted. The poser or authorisation or any other document consisting of adequate proof of the ability of the signatory to bind the firm/company should be annexed to the bid.
- iv) Tender documents with proper seal and signature of authorised person on each page of the bid must be submitted.
- v) The Complete specifications, Make/Model/Brand of Machine/item/equipment & its accessories offered on parameters specified as per Annexure-A, must be mentioned. The details with values for individual specifications/parameters desired must be indicated at Annexure 'B2' to this tender document.
- vi) Copy of GST Registration Certificate, duly signed & stamped.
- vii) The tenderer should have an average annual turnover of not less than 30% of the estimated cost during the last 03 financial years i.e. FY: 2015-16, 2016-17 & 2017-18. In order to authenticate, **a certificate regarding average turnover from a qualified Chartered Accountant is required to be furnished along with 'TC-Bid'**.
- viii) Copy of income tax return for the last three Assessment years, i.e. AY-2016-17, 2017-18 & 2018-19, duly signed & stamped.
- ix) Only the OEM / authorised distributors/ authorised dealers are allowed to bid for machine/equipment/items/stores mentioned in the tender document. The Authorisation letter from Principal/OEM must be enclosed.
- x) The tenderer must have completed similar supply orders/ contracts/ agreements minimum 03 nos. of any Govt./ PSU/ Govt. Aided Organization/ Institution/ Private Organization in last 05 years, or as specified at Annexure-A, **ending Nov. 2018**. Please enclose copy of such supply orders/contracts/agreements along with completion certificate/ proof of the same issued by the client.
- xi) Undertaking stating that "The delivery, installation and commissioning of the Machine/ item/ equipment must be completed within the stipulated period as indicated in the tender or specified at Annexure-A, from the date of placement of PO/work contract (within 6 months from date of placement of order)" **in the format enclosed at Appendix-1**.
- xii) The tenderer should submit an undertaking that his/her firm has not been debarred/blacklisted/terminated/banned to participate in the tender by any Govt. Institution, PSUs, and State Govt. or Central Govt. Deptt. **in the format enclosed at Appendix-2**.
- xiii) The tenderer should submit an undertaking that his/her offer is valid for acceptance for 90 days from the date of opening of TC Bids **in the format enclosed at Appendix-3**.

- xiv) Undertaking to the effect that all the tender terms & conditions are acceptable to the bidder **in the format enclosed at Appendix-4.**
- xv) Undertaking to the effect that a Performance Bank Guarantee (PBG) of 10% of the order value, valid for warranty period & claim submission date within 3 months from the date of expiry of Bank Guaranty/warranty period will be submitted after the commissioning of the Machine/item/equipment **in the format enclosed at Appendix-5.** The security deposit (including EMD) shall be released on receipt of 10% PBG valid for warranty period.
- xvi) The tenderer should submit an undertaking that his/her firm shall provide the complete training regarding operation & maintenance of the Machine/item/equipment & its accessories **in the format enclosed at Appendix-6.**
- xvii) The tenderer should submit an undertaking for unconditional acceptance to replace the supplies if rejected at the destination **in the format enclosed at Appendix-7.**
- xviii) Undertaking to be submitted by the tendered that "They should undertake that they will execute AMC for the period of 03 years after the expiry of warranty period as per the requirement of ALIMCO We hereby undertake that we will execute AMC for the period of 03 years after the expiry of warranty period as per the requirement of ALIMCO. And the AMC shall not exceed 4%, 6% and 7% of the basic value of machine during 3rd year, 4th year and 5th year respectively, from the date of successful installation and commissioning of the machine/ item/ equipment." **in the format enclosed at Appendix-8.**
- xix) Undertaking to be submitted by the tenderer that "payment terms mentioned at Para No-15 of this tender document (i.e. Terms of Payment) is acceptable" **in the format enclosed at Appendix-9.**
- xx) Tenderers are required to submit "**Tender Acceptance Letter**" in the format enclosed at **Appendix-10.**
- xxi) Tenderers are required to submit "**Undertaking**" regarding availment of GST and matching of Input credit in the format enclosed at **Appendix-11.**
- xxii) Tenderers are required to submit duly filled **Annexure 'B1 & B2'**, enclosed herewith.

(All these documents / details / conformation should necessarily be submitted specifically & in the same order.)

NOTE:

- i) Price bids of only those tenderers, who are assessed as technically qualified by the Corporation shall be opened & only Such parties shall be communicated regarding date & time of Price Bid opening requesting them to attend the Tender opening, if interested.

Part II ('P'BID): shall consist of complete price details as under: -

P Bid offer shall be uploaded online. Rate should be quoted in Rupee per unit **as per format at Annexure-C (P-bid).** Rate should be quoted for FREE DELIVERY at destination as indicated in Para 1 & should be without any price escalation clause. The following data shall be invariably furnished: -

- a) GSTIN No., HSN Code, GST in % & Rs.
- b) Packing & Forwarding charges, Installation charges, if any, in % & Rs.
- c) Freight charges in % & Rs. at FOR ALIMCO, HQ, Kanpur (destination as indicated in para-1).
- d) Charges for installation and commissioning (if any) may please be clearly indicated. Alternatively, rates quoted shall be considered to be inclusive of installation & commissioning charges.

THIS BREAKUP IS ESSENTIAL TO ENABLE PLACEMENT OF THE PURCHASE ORDERS AND PAYMENTS BY H.Q./AAPC's AS THE CASE MAY BE AND KEEPING IN VIEW APPLICABILITY OF GST BY THE GOVERNMENT w.e.f. 1st July 2017

The L1 offer will be decided based on landed cost at ALIMCO (destination as indicated in para-1).

NOTE: ALIMCO GST Registration details are given below.

	H.Q, Kanpur	AAPC, Jabalpur	AAPC, Bangalore	AAPC, Bhubaneswar	AAPC Ujjain
GST Regd. No.	09AABCA8899F1Z6				

Variation Clause: - Any change (Increase / Decrease) in Govt. Duties / Levies / Taxes GST as amended made applicable by Govt. (State / Central) from time to time at the rate as will be applicable over & above the basic price/rate quoted by parties in their offer during the currency of Purchase Order/Contract shall be considered by the Corporation for amendment on party's request along with necessary documents in support of their claim/amendment.

4. **SITE INSPECTION :** The tenderers shall be deemed to have inspected and examined the site and its Surrounding and information available in connection therewith and to have satisfied himself, so far as is practicable, before submitting his tender, to the extent and nature of work and materials Necessary for completion of works, availability of such materials, the means of access to the site and the accommodation that he may require and, in general, shall be deemed to have obtained all necessary information.
5. All the bids so received against the tender shall be scrutinized and assessed for Machine/ equipment/ item suitability offered by you. Offers of only those tenderers whose bids are found conforming to laid-down specifications and qualifying our requirements shall be considered. Quotes with any variation in the specifications affecting functions of the machine/ equipment/ item as specified are liable for outright rejection. Tenderers are therefore requested not to quote for nonconforming specifications Machines/Equipment's as an alternative one or two otherwise, for which tenders are liable for rejection. Each value as specified is to be mentioned in tenders and words "as specified" or "same" shall not be considered valid at all.
6. No change in specifications by tenderers shall be permissible after submission of Technical Bids.
7. **EARNEST MONEY DEPOSIT & SECURITY DEPOSIT:**

All the Tenderer must submit Rs. 5,00,000/- by **Demand Draft** or **Pay Order** or **Bankers Cheque** only in favour of **ALIMCO**, payable at **KANPUR** as **Earnest Money Deposit (EMD)** along with 'TC' BID. No other mode is acceptable. The EMD shall be released within 30 days of finalization of the purchase orders to the unsuccessful tenderers. No interest will be payable on the EMD.

All SSI units / Micro & Small Enterprises (MSE) will be issued Tender Documents free of cost & Exemption to submit Earnest Money Deposit (EMD) on submission of valid Udyog Aadhar Memorandum (UAM) against Tender for the items/nature of business/ type of services specified therein in the UAM. The amount of Earnest Money should be furnished in the form of Demand Draft or Pay Order or Bankers Cheque only. No interest shall be claimed/ payable on the bid- security/ EMD furnished to the Corporation.

The earnest money shall be forfeited if the tenderer withdraws his tender before the period of validity of the tender (i.e. minimum 90 days) and / or tenderers fails to furnish requisite security deposit within the specified period after the award of order/contract wherever applicable.

Subsequent to placement of Order / Contract, the successful tenderer will be required to deposit a sum equal to 10% of the Order/ Contract value subject to a maximum of Rs. 100.00 lakh, within 30 days from the date of purchase order as **Security Deposit (SD)** in the form of 'Demand Draft' or 'Pay Order' or 'Bankers Cheque' or 'Irrevocable Bank Guarantee from any of Nationalized Bank in the prescribed format enclosed at **Annexure-E** only in favour of **ALIMCO** payable at **Kanpur** for due discharge of the Purchase Order released on the basis of this tender. This will be retained till the expiry of warranty Period for the Item/stores/machine/material supplied. No interest will be payable on the Security Deposit. The earnest money already submitted with the tender may be adjusted towards Security Deposit. The Earnest Money deposit of the successful bidder will be returned / refundable only on receipt of valid & acceptable Security deposit. The successful vendor may also give their consent/request for retaining/converting their EMD into part of Security deposit & deposit the balance amount towards SD.

The Security deposit may be refunded/returned on submission of irrevocable, unconditional & acceptable Bank guarantee as performance guarantee by the party to cover its obligations to offer free of cost replacement under the warranty period from any nationalized bank. The corporation may also consider, at its discretion, acceptance of Corporate Guarantee given by Foreign Principal In lieu of Bank Guarantee in case of imported goods.

Security deposit shall be furnished within the time limit provided for in the Contract. Non submission of Security deposit within the time specified for the purpose shall amount to the breach of essential conditions of the Contract and shall render the Contract liable to cancellation & the contractor shall be liable for all consequence thereof or caused there by.

After Satisfactory installation and commissioning of the machine/ equipment/ item and on receipt of Performance Bank Guarantee equal to 10% of the PO/work contract Value, valid for the warranty period, the Security deposit amount (including of EMD) shall be released by ALIMCO.

The Corporation reserves the right to forfeit the earnest/security money deposit in case the supplier fails to make good losses on supplies, unable to replace supplies found unacceptable as well as losses on account of exceptional delays in supplies.

8. Submission of Tender

The tender shall be submitted online in two part, viz., technical bid and price bid

Technical Bid (TC Bid)

The following documents are to be furnished by the tenderer along with **Technical Bid** as per the tender document

- 1) Scanned copy of DD against tender document cost & EMD / Exemption Certificate.
- 2) Scanned copy of all relevant documents as per Tender.
- 3) Original copy of DD against tender fees and EMD must reach ALIMCO, Kanpur on or before **date 18.01.2019** Please note that no indication of the rates/amounts be made in any of the documents submitted with the TC-BID

PRICE BID (P Bid)

- (a) Schedule of price bid in the form of Annexure-C.

9. **OPENING & EVALUATION OF TENDER:**

- a) The tenders shall be opened online at <https://eprocure.gov.in/eprocure/app> at 15.30 hours on due date in presence of representatives of tenderers who may like to be present. Bidder can view live bid opening at their remote end also. Bids will be opened as per date/time as mentioned in the Tender Critical Date Sheet. After online opening of Technical-Bid the results of their qualification as well Price-Bid opening will be intimated latter.
- b) Only the 'TC-Bid' (Part I) of the tender will be opened online on **21.01.2019 at 15.30 Hrs.** by the Tender Opening Committee of ALIMCO in the presence of representatives of tenderers who may like to be present. **Tenders received late will not be considered. If the due date happens to be a holiday the same stands extended to the date of next working day with time remaining the same. However, the Corporation has the right to alter the date & time of Tender closing & opening. The same shall be notified only on the website of the Corporation.** The procedure will be as follows:
- c) Subsequent to opening of 'TC-BID' of all tenderers correspondence / discussion with regard to the conditions and other technical aspects may be held by the Technical Committee or by Officer(s) nominated by ALIMCO, if needed
- d) In case any tenderer submit only 'TC-BID' his tender shall not be considered and shall be treated as incomplete tender. Similarly, if any tenderer submit only 'P-BID', the same shall also be not considered.
- e) The technical bids will be evaluated to shortlist the eligible bidders. The technical bids of only the eligible bidders shall be considered for further processing (technical evaluation). Preliminary scrutiny of the proposal will be made to determine whether they are complete, required processing tender fee and EMD have been furnished whether the documents have been properly signed, and

whether the bids are generally in order. Proposals not conforming to such preliminary requirements will be prima facie rejected.

- f) The ALIMCO has a right to seek clarification/ documents from the tenderer relating to TC-Bid of tenderers if such information is essential for evaluation of tender.
- g) Bidder whose technical bid is found to be acceptable and meeting the Mandatory/Pre-qualification criteria as specified in this tender will only be informed about the date and time of the opening of the commercial bid (P-Bid).
- h) ALIMCO will open commercial bids of only the technically shortlisted bids, in the presence of the bidder or their authorised representative who choose to attend the bid opening, at the time and date to be informed later.
- i) Commercial bids of only those bidders will be opened who are found to be technically qualified & acceptable and the work shall be awarded to the commercially lowest bidder. The comparative statement of quotations (CSQ) of the P-bid will be prepared on FOR ALIMCO (as per defined destination in Para 1) and evaluated on the basis of complete price FOR ALIMCO (as per defined destination in Para 1) of the Machine/item/equipment including basic price, packing & forwarding, freight, taxes, installation & commissioning charges, etc.

10. REJECTION OF TENDER:

- a) Tenders received without EMD are liable to be rejected as also indicated at Para 7.
- b) Conditional and unsigned tenders, tenders containing absurd or unworkable rates and amounts, tenders which are incomplete or otherwise considered defective and tenders not in accordance with the tender conditions, drawings/specifications etc. are liable to be rejected.
- c) Canvassing in any form in connection with the tender is strictly prohibited and the tenders submitted by the party who resort to canvassing are liable to be rejected.
- d) The acceptance of tender will rest with ALIMCO which does not bind itself to accept the lowest tender or any tender and reserves full rights for the rejection of any or all tenders without assigning any reasons whatsoever.

11. VALIDITY OF TENDER:

- a) The tenders shall remain open for acceptance for a minimum period validity of 90 days from, the date of opening of tenders or till such period up to which the extension of validity is agreed to mutually. This may please be stipulated clearly in the Quotation.
- b) If notified within this period that the tender has been accepted, the tenderer shall be bound by the terms of the offer along with the terms that have been agreed mutually.
- c) All the tenders without PROPER SPECIFICATION / MAKE / BRAND / BROCHURE /CATALOUGE/ LEAFLET & TEST CERTIFICATES wherever required, are liable to be rejected. It shall be in the interest of the tenderer that complete offer is made for our consideration. It will be in the interest of the tenderer to submit details/values against each individual parameter as mentioned at Annexure 'B2' and sample wherever possible along with the offer.
- d) In case the tenderer happens to be dealer/distributor for any reputed brand the validity certificate to this effect duly certified from the principal should invariably be provided.

12. QUANTITY DISCOUNT:

In order to submit the most competitive offer, the Tenderer may indicate the quantity discounts as applicable on the price. However, the buyer reserves the right to accept the quantity discounts for lower quantities as well. The quantities indicated in the Annexure 'A' are liable to revision either upwards or downwards.

13. DELIVERY:

- a) The delivery, installation and commissioning of the Machine/item/equipment and its accessories must be completed within the stipulated period specified at Annexure-A, from the date of placement/acceptance of PO/ work contract.
- b) The delivery of the Machine/item/equipment shall be made strictly as per delivery schedule as stipulated in our Purchase Order/Work Contract or modified time to time by ALIMCO. Failure to supply, install & commission within the stipulated period will make the tenderers liable to an unconditional penalty of ½ % of our Purchase order / Work Contract value per week subject to a maximum limit of 10% value of our Purchase Order/Work Contract.

14. INSPECTION:

- a) Inspection will be carried out at the Destination (refer Para 1) and unacceptable/ rejected Item will be returned to the supplier through bank at the supplier's risk and cost by road, only after receipt and acceptance of replacement supplies provided by the suppliers free of cost. Alternatively, all the tenderer will have to furnish their Banker's Name, Address including Code No. along with a declaration/undertaking to guarantee collection of the returned supplies documents negotiated through their bank within 07 days of its presentation.
- b) In case of local supplier, rejected Item shall be lifted from our stores within 15 days of our rejection advice after refunding the payment, if already made to them before collecting the supply. In case of failure to lift the rejected Item, we may dispose-off the rejected Item as deemed fit and no claim whatsoever shall be entertained in this respect and the tenderer shall be liable to pay amount paid by ALIMCO, if any.

15. TERMS OF PAYMENT:

ALIMCO is a Schedule 'C' Mini Ratna Category II Central Public Sector Enterprises, registered under Section 8 (Not for Profit motive) of the Companies Act, 2013, (corresponding to Section 25 of the Companies Act, 1956). The terms of payment shall be as follows:

- a) 80% (excluding GST)payment shall be released within 30 days after receipt of the machine / equipment /stores and its accessories at destination as specified in Para 1 without any damage/short supplies and balance 20% (excluding GST)payment shall be released within 30 days after installation & commissioning of the machine/item/equipment and its accessories subject to receipt of performance guarantee from a nationalized bank equal to 10% of the PO/work contract Value, valid for the warranty period & claim submission date within 3 month from the date of expiry of Bank Guaranty/warranty period.
- b) Any expenses towards transit insurance to be borne by the tenderer.
- c) In case of PDI at party's worksite, all the cost to be borne by ALIMCO. Going for PDI is at sole discretion of ALIMCO, tenderer to inform the tentative dates for PDI at their work.
- d) GST portion shall be paid on availment and matching of Input Credit.
- e) Supplier's Bank Charges/Draft making charges will have to be borne by the party only.
- f) The tenderer will be required to submit their RTGS details duly certified by the Bank along with a crossed/cancelled Cheque in support of the details, as all payments/refunds are preferably be made through RTGS.

16. RIGHT OF ACCEPTANCE:

ALIMCO reserves the right to reject any or all the tenders in part or full without assigning any reasons thereof. The Corporation also reserves the right to negotiate the rates and terms and conditions of supply with any or all the tenderers at its sole discretion as deemed fit without assigning any reasons thereof.

ARBITRATION

In case of any dispute, arising during the operation of the contract, efforts shall be made to resolve it by mutual discussions failing which the matter shall be referred to the Chairman & Managing Director of ALIMCO G.T. Road, Kanpur-209217 or his nominee whose decision shall be final and binding on both the parties. Arbitration proceedings shall be held at Kanpur as per provisions of the Arbitration & Conciliation Act 1996 and the Kanpur City Court shall have the jurisdiction in the matter.

Thanking you,

Yours faithfully,
for Artificial Limbs Mfg. Corporation of India

Senior Manager (SP&C)

Encl: As Above

“CNC Tube Bending Machine & Its Software” (On Turnkey Basis)

Code No.

Qty. – 01 Set.

Purpose: CNC tube bending machine for bending of MS/Al/SS tubes.**SPECIFICATIONS:**

SL. NO.	DESCRIPTION OF REQUIREMENT	REQUIRED
1	Scope	
1.1	Maximum tube size (Diameter X thickness)	At-least up-to 29 X 2 (mm) or more; Ferrous and Aluminium tubes
1.2	Minimum tube size (Diameter)	14 mm or less
1.3	Maximum Bend radius	At-least up to 160 mm
1.4	Minimum Bend radius	1.5 x Diameter
1.5	Tube length for bending operation	At-least up-to 3 meter
1.6	Bend angle range	At-least up to 180°
1.7	Direction of bending	Left and Right
1.8	Operations	All Electric
1.9	Working height of tube mandrel	Min. 1000 mm
1.10	Offline programming (Bending, Drawing, Networking and Nesting) software for 3D graphic programming from offline computer with check for part feasibility and machine programme optimization (should be compatible with .Step files, .iges files, .Dxf files etc.)	Vendor to confirm
1.11	Suitable system (laptop) along with post-processor for 3D graphic programming on PC	Confirm
2	Tooling : Tool Set for MS & AL Tubes (including mandrel tie rods, dies and clamp brackets etc.) as per attached drawings for the bending parts	1 set each (Refer attached drawing)
2.1	MS Tube ERW-C1 (1 set)	17.08mm OD X 0.9 mm thk
2.2	MS Tube ERW-C1 (1 set)	19.05mm OD X 1 mm thk
2.3	MS Tube ERW-C1 (1 set)	22.23mm OD X 1.63 mm thk
2.4	MS Tube ERW-C1 (1 set)	25.4mm OD X 1.25 mm thk
2.5	MS Tube ERW-C1 (1 set)	25.4mm OD X 1.63 mm thk
2.6	MS Tube ERW-C1 (1 set)	28.6mm OD X 1.63 mm thk
2.7	ERW Steel tube STKM11A	19.5mm OD X 1 mm thk
2.8	ERW Steel tube STKM11A	25.4mm OD X 1 mm thk
2.9	ERW Steel tube STKM11A	22.2mm OD X 1.4 mm thk
2.10	Aluminium 6063 T6	25.4mm OD X 2 mm thk
2.11	Aluminium 6063 T6	22.2mm OD X 2 mm thk
3	Axis controls (Ref. attached schematic)	
3.1	Carriage movement (X)	Min. 2000 mm
3.2	Bend angle (Y)	Min. 190°
3.3	Plane rotation of the tube (Z)	At-least up to 540°
3.4	Bend head rotation (R)	Min. 300°
3.5	Horizontal bend head movement (Q)	± 475 mm
3.6	Clamping right hand (W ₃)	Min. 165 mm
3.7	Clamping left hand (W ₅)	Min. 165 mm

3.8	Mandrel extraction (U ₂)	Max. 600 mm
3.9	Pressure die right hand (W ₄)	Min. 150 mm
3.10	Pressure die left hand (W ₆)	Min. 150 mm
3.11	Right follower die (U ₄)	Min. 120 mm
3.12	Left follower die (U ₅)	Min. 120 mm
4	Controller	
4.1	Control	Siemens SIMOTION / Fanuc / Equivalent OEM control (vendor to submit equivalency document)
4.2	Processor	Min. Intel core i7 version of processor with min. 4 GB RAM 32 GB solid state drive
4.3	Connection	Min. 2 Ethernet & 2 USB connections
4.4	Panel	Min. 12" colour monitor touch screen operator panel with keyboard
4.5	Digital drives	Siemens / Fanuc / ABB / OMRON
5	Function which enables the automatic generation of bend compensation data including spring back compensation for specific material as per attached drawings	Confirm
6	Machine Speed, accuracy and stroke	
6.1	Maximum tube displacement axis speed (X)	At-least 1400 mm/sec
6.2	Displacement axis speed tolerance	± 0.05 mm
6.3	Maximum bending axis speed (Y)	At-least 300 ⁰ /sec
6.4	bending axis speed tolerance	± 0.05 ⁰
6.5	Maximum tube rotation axis speed (Z)	At-least 400 ⁰ /sec
6.6	tube rotation axis speed tolerance	± 0.05 ⁰
6.7	Maximum head horizontal displacement axis speed (Q)	At-least 800 mm/sec
6.8	head horizontal displacement axis speed tolerance	± 0.1 mm
6.9	Maximum head rotation axis speed (R)	At-least 120 ⁰ /sec
6.10	head rotation axis speed tolerance	± 0.05 ⁰
7	Other features	
7.1	Automatic Tube loading/ Unloading Station	Capacity 1 Ton or more
7.2	Ability to detect seam, hole slot and re-orient the bending line as per requirement	Confirm
7.3	Remote diagnostic capability (Machine should be capable of remotely connecting to OEM server and troubleshooting the problems to that)	Confirm
8	Detail of Necessary Lubrication and safety devices	Vendor to specify and confirm
8.1	Lubrication tank capacity	Min. 6 ltr.
9	Following necessary accessories/spares for successful operation of machine, should be provided by vendor	Confirm
9.1	Proximities & Limit switches	02 Sets
9.2	CNC Panel Board Keys	02 Sets
9.3	Oil seals (all sizes)	03 Set
9.4	O rings	03 set
9.5	Timing belt	03 Set
9.6	Wiper dies	02 Set

9.7	Pressure dies	01 Set
9.8	Fuses	03 Set
9.9	Ferrules	03 set
10	Machine compliance with CE/equivalent norms	Confirm
B	OTHER CONDITION	
11	Electrical System to be designed for	
11.1	3 Phase, 415V ($\pm 10\%$)	Confirm
11.2	Frequency: 50 Hz ($\pm 3\%$)	Confirm
11.3	Protection level	IP54 or better
12	Complete electrical system with tropicalization for Indian condition +5°C to +50°C temp and RH 100%	Confirm
13	Service	
13.1	In case of global OEM, the authorized Indian Service Partners must be certified by manufacturer	Confirm
13.2	Contact person name, address with details such as e-mail, contact no. to be provided by the vendor	Vendor to specify
14	Additional features	
14.1	Machine to have capability to handle voltage and current fluctuation	Confirm
14.2	Power backup required for min 15 minutes for CNC control system	Confirm
15	Separate list of consumable.	Vendor to provide list along with cost
16	Supplier shall undertake to supply machine spares/accessories up to minimum 10 years from date of supply as appendix-12	Confirm
17	Vendor to Submit the detail layout of machine	Vendor to submit along with technical details
18	Documentation: Following documents (3 sets of hard copy and 1 set of soft copy) along with delivery will be required	Confirm
18.1	Operating instruction	Confirm
18.2	Installation and Commissioning instructions	Confirm
18.3	Preventive maintenance instructions	Confirm
18.4	Lubrication chart & parameter list	Confirm
18.5	Lifting instruction mentioned in packing list.	Confirm
18.6	Detailed invoice and packing list of all items and all other accessories enclosed in respective boxes	Confirm
19	Training at site	
19.1	Operation and Programming	4 Week
19.2	Preventive maintenance training	1 Week
20	Prove-out:	
20.1	Vendor to perform complete trial run and prove out	Confirm
20.2	Vendor has to prove-out on 5 complete sets at ALIMCO premises after installation and commissioning (Refer attached tender drawings).	Confirm
21	Delivery period including installation and commissioning: within 6 months	Confirm
22	Vendor to deliver machine at "ALIMCO Kanpur site"	Confirm
23	Packaging and Transportation is in scope of vendor	Confirm
24	Installation and Commissioning should be done within 21 days on receipt of machine at site by the vendor. All necessary calibrations shall be done by vendor before handover the machine.	Confirm

DELIVERY PERIOD INCLUDING INSTALLATION & COMMISSIONING:

The delivery period including installation & commissioning of the machines at the destination mentioned in Para 1 on page no. 02 of the tender documents will be 06 months from the date of placement of Purchase Order/work contract.

WARRANTY:

The machine inclusive of all system/accessories should be covered under warranty for a period of 24 months from the date of commissioning.

Note:

1. Machine shall be supplied with 3 sets of comprehensive operation and maintenance manual.
2. Breakdown calls to be attended within 72 hrs. Physically or within 24 hrs. through tele-diagnostic.
3. Civil foundation details and drawings with specifications to be provided by the tenderer. Vendor to arrange any civil foundation work, if required, for the installation of machine.
4. Total power consumption (in kW) to be provided by the tenderer.
5. The Bus-bar trunking (BBT) line for electricity has been provided at 8.5 meter height. Sufficient suitable cable, cable tray, Circuit breaker, fittings to connect the machine from power source is in Vendor's scope.
6. Compressed air pipeline is available in the work center (Air pressure available will be approx. 4.5 to 6 bar), all necessary fittings, air dryer, air booster as per machine requirements, is in vendor scope.
7. ALIMCO will install machine at a temporary location during first installation. After the new facility is ready, the same will be shifted to that. Vendor to quote separate price for dismantling, re-installation and re-commissioning of machine at new facility. The price to be quoted separately along with price-bid. The order of same will be release separately at ALIMCO discretion (ref. Additional Annexure).
8. Vendor to ensure operation and maintenance training for 7 days, at OEM premises. ALIMCO will bear the cost of travelling, lodging and fooding.
9. Vendor to ensure, to supply additional quantity of oil and lubricants for at-least two more fills along with initial fill.

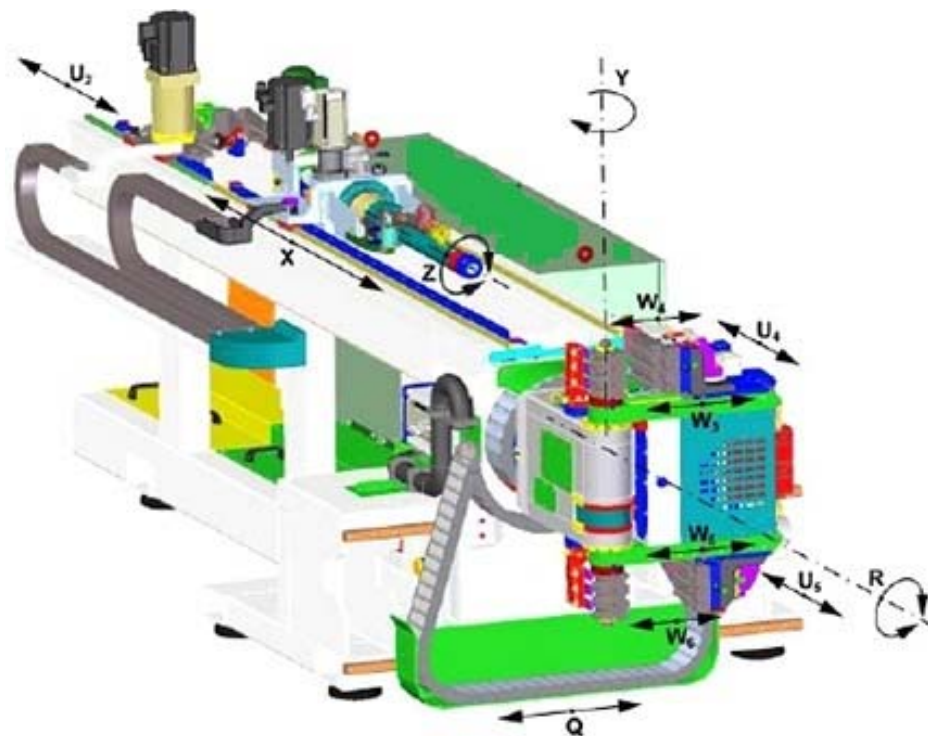

Fig.: Schematic of CNC Tube Bending Machine (for reference)

(On Letter Head of the Tenderer)

APPENDIX-1

UNDERTAKING

We hereby undertake that The delivery, installation and commissioning of the Machine/item/equipment & its accessories must be completed within the stipulated period as indicated in the tender or specified at Annexure-A from the date of placement of PO/work contract (within 6 months from date of placement of order)".

Dated:

Authorised Signatory :

Name :-

Designation :-

Seal :-

(On Letter Head of the Tenderer)

APPENDIX -2

UNDERTAKING

We hereby undertake that our Firm has not been debarred/blacklisted/terminated/banned to participate in the Tender by any Govt. Institution, PSU, State Govt. or Central Govt. Deptt.

Dated:

Authorised Signatory :

Name :-

Designation :-

Seal :-

(On Letter Head of the Tenderer)

APPENDIX -3

UNDERTAKING

We hereby undertake that our Offer is valid for acceptance for 90 days from the date of opening of Techno-Commercial Bid (TC-Bid).

Dated:

Authorised Signatory :

Name :-

Designation :-

Seal :-

(On Letter Head of the Tenderer)

APPENDIX -4

UNDERTAKING

We hereby undertake that all the tender terms & conditions are acceptable to us.

Dated:

Authorised Signatory :

Name :-

Designation :-

Seal :-

(On Letter Head of the Tenderer)

APPENDIX -5

UNDERTAKING

We hereby undertake that a Performance Bank Guarantee (PBG) of 10 % of the order value, valid for warranty period & claim submission date within 3 month from the date of expiry of Bank Guaranty/warranty period, will be submitted after the commissioning of the Machine/item/equipment & its accessories.

Dated:

Authorised Signatory :

Name :-

Designation :-

Seal :-

(On Letter Head of the Tenderer)

APPENDIX -6

UNDERTAKING

We hereby undertake that our firm shall provide the complete training regarding operation & maintenance of the Machine/item/equipment & its accessories.

Dated:

Authorised Signatory :

Name :-

Designation :-

Seal :-

(On Letter Head of the Tenderer)

APPENDIX -7

UNDERTAKING

We hereby undertake that we will unconditionally accept to replace the supplies if rejected at the destination.

Dated:

Authorised Signatory :

Name :-

Designation :-

Seal :-

(On Letter Head of the Tenderer)

APPENDIX -8

UNDERTAKING

We hereby undertake that we will execute AMC for the period of 03 years after the expiry of warranty period as per the requirement of ALIMCO. And the AMC shall not exceed 4%, 6% and 7% of the basic value of machine during 3rd year, 4th year and 5th year respectively, from the date of successful installation and commissioning.

Dated:

Authorised Signatory :

Name :-

Designation :-

Seal :-

(On Letter Head of the Tenderer)

APPENDIX -9

UNDERTAKING

We hereby undertake that payment terms mentioned at Para No-15 of this tender document (i.e. Terms of Payment) is acceptable to us.

Dated:

Authorised Signatory :

Name :-

Designation :-

Seal :-

TENDER ACCEPTANCE LETTER
(To be given on Company Letter Head)

Date:

To,

Sub: Acceptance of Terms & Conditions of Tender.

Tender Reference No: _____

Name of Tender / Work: -

Dear Sir,

1. I / We have downloaded / obtained the tender document(s) for the above mentioned 'Tender/Work' from the web site(s) namely:

as per your advertisement, given in the above mentioned website(s).

2. I / We hereby certify that I / we have read the entire terms and conditions of the tender documents from Page No. _____ to _____ (including all documents like annexure(s), schedule(s), etc .,), which form part of the contract agreement and I / we shall abide hereby by the terms / conditions / clauses contained therein.

3. The corrigendum(s) issued from time to time by your department/ organisation to have also been taken into consideration, while submitting this acceptance letter.

4. I / We hereby unconditionally accept the tender conditions of above mentioned tender document(s) / corrigendum(s) in its totality / entirety.

5. I / We do hereby declare that our Firm has not been blacklisted/ debarred/ terminated/ banned by any Govt. Department/Public sector undertaking.

6. I / We certify that all information furnished by our Firm is true & correct and in the event that the information is found to be incorrect/untrue or found violated, then your department/ organisation shall without giving any notice or reason therefore or summarily reject the bid or terminate the contract, without prejudice to any other rights or remedy including the forfeiture of the full said earnest money deposit absolutely.

Yours Faithfully,
(Signature of the Bidder, with Official Seal)

(On Letter Head of the Tenderer)

UNDERTAKING

We hereby confirm that payment of basic value within 30 days after supply & acceptance/approval of Machine/item/equipment & its accessories or Submission of bill, whichever is later, is acceptable to us. However, the GST portion shall be claimed only after submission of GST Return and Input credit appearing in corporation's GST portal, filed online by the tenderer clearly (duly highlighted) showing invoice/ bill number and amount to ALIMCO so as to enable the Corporation to avail GST input credit after matching of the GST return and Invoice submitted in the Corporation. No claim against the Corporation shall be made for non- matching of GST and the amount shall be credited back by us.

Dated:

Authorised Signatory:

Name:-

Designation

Seal:-

(On Letter Head of the Tenderer)

UNDERTAKING

We hereby confirm that, we will supply machine spares/accessories up to minimum 10 years from date of supply.

Dated:

Authorised Signatory:

Name:-

Designation

Seal:-

Instructions for Online Bid Submission:

The bidders are required to submit soft copies of their bids electronically on the CPP Portal, using valid Digital Signature Certificates. The instructions given below are meant to assist the bidders in registering on the CPP Portal, prepare their bids in accordance with the requirements and submitting their bids online on the CPP Portal.

More information useful for submitting online bids on the CPP Portal may be obtained at: <https://eprocure.gov.in/eprocure/app>.

Registration:

1. Bidders are required to enrol on the e-Procurement module of the Central Public Procurement Portal (URL: <https://eprocure.gov.in/eprocure/app>) by clicking on the link "Online bidder Enrolment" on the CPP Portal which is free of charge
2. As part of the enrolment process, the bidders will be required to choose a unique username and assign a password for their accounts.
3. Bidders are advised to register their valid email address and mobile numbers as part of the registration process. These would be used for any communication from the CPP Portal.
4. Upon enrolment, the bidders will be required to register their valid Digital Signature Certificate (Class II or Class III Certificates with signing key usage) issued by any Certifying Authority recognized by CCA India (e.g. Sify / nCode / eMudra etc.), with their profile.
5. Only one valid DSC should be registered by a bidder. Please note that the bidders are responsible to ensure that they do not lend their DSC's to others which may lead to misuse.
6. Bidder then logs in to the site through the secured log-in by entering their user ID/Password and the password of the DSC/e-Token.

Searching For Tender Documents:

1. There are various search options built in the CPP Portal, to facilitate bidders to search active tenders by several parameters. These parameters could include Tender ID, Organization Name, Location, Date, Value, etc. There is also an option of advanced search for tenders, wherein the bidders may combine a number of search parameters such as Organization Name, Form of Contract, Location, Date, Other keywords etc. to search for a tender published on the CPP Portal.
2. Once the bidders have selected the tenders they are interested in, they may download the required documents/tender schedules. These tenders can be moved to the respective 'My Tenders' folder. This would enable the CPP Portal to intimate the bidders through SMS/e-mail in case there is any corrigendum issued to the tender document.
3. The bidder should make a note of the unique Tender ID assigned to each tender, in case they want to obtain any clarification/help from the Helpdesk.

Preparation of Bids:

- a. Bidder should take into account any corrigendum published on the tender document before submitting their bids.
- b. Please go through the tender advertisement and the tender document carefully to understand the documents required to be submitted as part of the bid. Please note the number of covers in which the bid documents have to be submitted, the number of documents - including the names and content of each of the document that need to be submitted. Any deviations from these may lead to rejection of the bid.

- c. Bidder, in advance, should get ready the bid documents to be submitted as indicated in the tender document / schedule and generally, they can be in PDF / XLS / RAR / DWF/JPG formats. Bid documents may be scanned with 100 dpi with black and white option which helps in reducing size of the scanned document.
- d. To avoid the time and effort required in uploading the same set of standard documents which are required to be submitted as a part of every bid, a provision of uploading such standard documents (e.g. PAN card copy, annual reports, auditor certificates etc.) has been provided to the bidders. Bidders can use “My Space” or “Other Important Documents” area available to them to upload such documents and keep it as a repository.

Note: My Documents space is only a repository given to the Bidders to ease the uploading process. If Bidder has uploaded his Documents in My Documents space, this does not automatically ensure these Documents being part of Technical Bid.

Submission of Bids:

1. Bidder should log into the site well in advance for bid submission so that they can upload the bid in time i.e. on or before the bid submission time. Bidder will be responsible for any delay due to other issues.
2. The bidder has to digitally sign and upload the required bid documents one by one as indicated in the tender document.
3. Bidder has to select the payment option as “offline” to pay the tender fee/EMD as applicable and enter details of the instrument.
4. Bidder should prepare the EMD as per the instructions specified in the tender document. The original should be posted/ couriered/given in person to the concerned official, latest by the last date of bid submission or as specified in the tender documents. The details of the DD/any other accepted instrument, physically sent, should tally with the details available in the scanned copy and the data entered during bid submission time. Otherwise the uploaded bid will be rejected.
5. Bidders are requested to note that they should necessarily submit their financial bids in the format provided and no other format is acceptable. If the price bid has been given as a standard BoQ format with the tender document, then the same is to be downloaded and to be filled by all the bidders. Bidders are required to download the BoQ file, open it and complete the white coloured (unprotected) cells with their respective financial quotes and other details (such as name of the bidder). No other cells should be changed. Once the details have been completed, the bidder should save it and submit it online, without changing the filename. If the BoQ file is found to be modified by the bidder, the bid will be rejected.
6. The server time (which is displayed on the bidders’ dashboard) will be considered as the standard time for referencing the deadlines for submission of the bids by the bidders, opening of bids etc. The bidders should follow this time during bid submission.
7. All the documents being submitted by the bidders would be encrypted using PKI encryption techniques to ensure the secrecy of the data. The data entered cannot be viewed by unauthorized persons until the time of bid opening. The confidentiality of the bids is maintained using the secured Socket Layer 128 bit encryption technology. Data storage encryption of sensitive fields is done. Any bid document that is uploaded to the server is subjected to symmetric encryption using a system generated symmetric key. Further this key is subjected to asymmetric encryption using buyers/bid openers’ public keys. Overall, the uploaded tender documents become readable only after the tender opening by the authorized bid openers.
8. The uploaded tender documents become readable only after the tender opening by the authorized bid openers.

9. Upon the successful and timely submission of bids (ie after Clicking “Freeze Bid Submission” in the portal), the portal will give a successful bid submission message & a bid summary will be displayed with the bid no. and the date & time of submission of the bid with all other relevant details.
10. The bid summary has to be printed and kept as an acknowledgement of the submission of the bid. This acknowledgement may be used as an entry pass for any bid opening meetings.

Assistance to Bidders:

1. Any queries relating to the tender document and the terms and conditions contained therein should be addressed to the Tender Inviting Authority for a tender or the relevant contact person indicated in the tender.
2. Any queries relating to the process of online bid submission or queries relating to CPP Portal in general may be directed to the 24x7 CPP Portal Helpdesk Nos. 0120-4200462, 0120-4001002

Sr. No.	Mandatory/Pre-Qualification Criteria	Complied / Not Complied	Provide details
B1			
1	Submit, scan copy of DD for Rs. 560/- (GST @ 12% Included) in favour of ALIMCO, payable at Kanpur towards cost of Tender documents, if downloaded from the website of the Corporation/CPPP and original copy of the same should reach to the office of Senior Manager (SP&C), Artificial Limbs Manufacturing Corporation of India, G. T. Road, Kanpur – 209 217 on or before dated 18.01.2019 (All SSI units/ MSE Vendors are exempted from Tender Cost).		
2	Earnest Money :-Submit scan copy of Demand Draft or Pay Order or Bankers Cheque for Rs. 5,00,000/- in favour of ALIMCO , payable at KANPUR as Earnest Money Deposit along with 'TC' BID and original copy of the same should reach to the office of Senior Manager (SP&C), Artificial Limbs Manufacturing Corporation of India, G. T. Road, Kanpur – 209 217 on or before dated 18.01.2019 . Exemption from Earnest Money Deposit (EMD) will be allowed to all SSI units/ Micro & small enterprises (MSE) on submission of valid Udyog adhaar memorandum (UAM) only (no other document shall exempt units from EMD) against tender for the items/nature of business/ type of services specified there in the UAM.		
3	The person signing the bid should be duly authorized representative of the firm/company whose signature should be verified and certificate of authority should be submitted. The poser or authorization or any other document consisting of adequate proof of the ability of the signatory to bind the firm/company should be annexed to the bid.		
4	Tender documents with proper seal and signature of authorized person on each page of the bid must be submitted.		
5	The Complete specifications, Make/Model/Brand of Machine/item/equipment & its accessories offered on parameters specified as per Annexure-A, must be mentioned. The details with values for individual specifications/parameters desired must be indicated at Annexure 'B2' to this tender document.		
6	Copy of GST Registration Certificate, duly signed & stamped.		
7	The tenderer should have an average annual turnover of not less than 30% of the estimated cost during the last 03 financial years i.e. FY: 2015-16, 2016-17 & 2017-18. In order to authenticate, a certificate regarding average turnover from a qualified Chartered Accountant is required to be furnished along with 'TC-Bid'.		
8	Copy of income tax return for the last three Assessment years, i.e. AY-2016-17, 2017-18 & 2018-19, duly signed & stamped.		
9	Only the OEM / authorized distributors/ authorized dealers are allowed to bid for machine/equipment/items/stores mentioned in the tender document. The Authorization letter from Principal/OEM must be enclosed.		
10	The tenderer must have completed similar supply orders/contracts/agreements minimum 03 nos. of Govt/PSU/Govt. Aided Organization/Institution/Private Organization order supply in last 05 years, or as specified at Annexure-A, ending Nov- 2018 . Please enclose copy of such supply orders/contracts/agreements along with completion certificate/proof of the same issued by the client.		
11	Undertaking stating that "The delivery, installation and commissioning of the Machine/ item/ equipment must be completed within the stipulated period as indicated in the tender or specified at Annexure-A, from the date of placement of PO/work contract (within 6 months from date of placement of order)" in the format enclosed at Appendix-1.		
12	The tenderer should submit an undertaking that his/her firm has not been debarred/ blacklisted/ terminated/ banned to participate in the tender by any Govt. Institution, PSUs, and State Govt. Or Central Govt. Deptt. in the format enclosed at Appendix-2.		

13	The tenderer should submit an undertaking that his/her Offer is valid for acceptance for 90 days from the date of opening of TC Bids in the format enclosed at Appendix-3.		
14	Undertaking to the effect that all the tender terms & conditions are acceptable to the bidder in the format enclosed at Appendix-4.		
15	Undertaking to the effect that a Performance Bank Guarantee (PBG) of 10% of the order value, valid for warranty period & claim submission date within 3 month from the date of expiry of Bank Guaranty/warranty period will be submitted after the commissioning of the machine/equipment/item in the format enclosed at Appendix-5.		
16	The tenderer should submit an undertaking that his/her firm shall provide the complete training regarding operation & maintenance of the Machine/item/equipment & its accessories in the format enclosed at Appendix-6.		
17	The tenderer should submit an undertaking for unconditioned acceptance to replace the supplies if rejected at the destination in the format enclosed at Appendix-7.		
18	Undertaking to be submitted by the tendered that "They should undertake that they will execute AMC for the period of 03 years after the expiry of warranty period as per the requirement of ALIMCO We hereby undertake that we will execute AMC for the period of 03 years after the expiry of warranty period as per the requirement of ALIMCO. And the AMC shall not exceed 4%, 6% and 7% of the basic value of machine during 3 rd year, 4 th year and 5 th year respectively, from the date of successful installation and commissioning of the machine/ item/ equipment." in the format enclosed at Appendix-8.		
19	Undertaking to be submitted by the tenderer that "payment terms mentioned at Para No-15 of this tender document (i.e. Terms of Payment) is acceptable" in the format enclosed at Appendix-9.		
20	Tenderers are required to submit "Tender Acceptance Letter" in the format enclosed at Appendix-10.		
21	Tenderers are required to submit "Undertaking" regarding availment of GST and matching of Input credit in the format enclosed at Appendix-11.		
22	Tenderers are also required to provide duly filled Annexure 'B1 & B2' , enclosed herewith.		

Annexure-B2

Tender No. – PT/OT/09/AW

Dtd.- 12.12.2018

S. NO.	DESCRIPTION OF REQUIREMENT	REQUIRED	COMPLIED / NOT COMPLIED	PROVIDE DETAILS
1	Scope			
1.1	Maximum tube size (Diameter X thickness)	At-least up-to 29 X 2 (mm) or more; Ferrous and Aluminium tubes		
1.2	Minimum tube size (Diameter)	14 mm or less		
1.3	Maximum Bend radius	At-least up to 160 mm		
1.4	Minimum Bend radius	1.5 x Diameter		
1.5	Tube length for bending operation	At-least up-to 3 meter		
1.6	Bend angle range	At-least up to 180°		
1.7	Direction of bending	Left and Right		
1.8	Operations	All Electric		
1.9	Working height of tube mandrel	Min. 1000 mm		
1.10	Offline programming (Bending, Drawing, Networking and Nesting) software for 3D graphic programming from offline computer with check for part feasibility and machine programme optimization (should be compatible with .Step files, .iges files, .Dxf files etc.)	Vendor to confirm		
1.11	Suitable system (laptop) along with post-processor for 3D graphic programming on PC	Confirm		
2	Tooling : Tool Set for MS & AL Tubes (including mandrel tie rods, dies and clamp brackets etc.) as per attached drawings for the bending parts	1 set each (Refer attached drawing)		
2.1	MS Tube ERW-C1 (1 set)	17.08mm OD X 0.9 mm thk		
2.2	MS Tube ERW-C1 (1 set)	19.05mm OD X 1 mm thk		
2.3	MS Tube ERW-C1 (1 set)	22.23mm OD X 1.63 mm thk		
2.4	MS Tube ERW-C1 (1 set)	25.4mm OD X 1.25 mm thk		
2.5	MS Tube ERW-C1 (1 set)	25.4mm OD X 1.63 mm thk		
2.6	MS Tube ERW-C1 (1 set)	28.6mm OD X 1.63 mm thk		
2.7	ERW Steel tube STKM11A	19.5mm OD X 1 mm thk		
2.8	ERW Steel tube STKM11A	25.4mm OD X 1 mm thk		
2.9	ERW Steel tube STKM11A	22.2mm OD X 1.4 mm thk		
2.10	Aluminium 6063 T6	25.4mm OD X 2 mm thk		
2.11	Aluminium 6063 T6	22.2mm OD X 2 mm thk		
3	Axis controls (Ref. attached schematic)			
3.1	Carriage movement (X)	Min. 2000 mm		
3.2	Bend angle (Y)	Min. 190°		
3.3	Plane rotation of the tube (Z)	At-least up to 540°		
3.4	Bend head rotation (R)	Min. 300°		
3.5	Horizontal bend head movement (Q)	± 475 mm		
3.6	Clamping right hand (W ₃)	Min. 165 mm		
3.7	Clamping left hand (W ₅)	Min. 165 mm		
3.8	Mandrel extraction (U ₂)	Max. 600 mm		
3.9	Pressure die right hand (W ₄)	Min. 150 mm		

3.10	Pressure die left hand (W ₆)	Min. 150 mm		
3.11	Right follower die (U ₄)	Min. 120 mm		
3.12	Left follower die (U ₅)	Min. 120 mm		
4	Controller			
4.1	Control	Siemens SIMOTION / Fanuc / Equivalent OEM control (vendor to submit equivalency document)		
4.2	Processor	Min. Intel core i7 version of processor with min. 4 GB RAM 32 GB solid state drive		
4.3	Connection	Min. 2 Ethernet & 2 USB connections		
4.4	Panel	Min. 12" colour monitor touch screen operator panel with keyboard		
4.5	Digital drives	Siemens / Fanuc / ABB / OMRON		
5	Function which enables the automatic generation of bend compensation data including spring back compensation for specific material as per attached drawings	Confirm		
6	Machine Speed, accuracy and stroke			
6.1	Maximum tube displacement axis speed (X)	At-least 1400 mm/sec		
6.2	Displacement axis speed tolerance	± 0.05 mm		
6.3	Maximum bending axis speed (Y)	At-least 300 ⁰ /sec		
6.4	bending axis speed tolerance	± 0.05 ⁰		
6.5	Maximum tube rotation axis speed (Z)	At-least 400 ⁰ /sec		
6.6	tube rotation axis speed tolerance	± 0.05 ⁰		
6.7	Maximum head horizontal displacement axis speed (Q)	At-least 800 mm/sec		
6.8	head horizontal displacement axis speed tolerance	± 0.1 mm		
6.9	Maximum head rotation axis speed (R)	At-least 120 ⁰ /sec		
6.10	head rotation axis speed tolerance	± 0.05 ⁰		
7	Other features			
7.1	Automatic Tube loading/ Unloading Station	Capacity 1 Ton or more		
7.2	Ability to detect seam, hole slot and re-orient the bending line as per requirement	Confirm		
7.3	Remote diagnostic capability (Machine should be capable of remotely connecting to OEM server and troubleshooting the problems to that)	Confirm		
8	Detail of Necessary Lubrication and safety devices	Vendor to specify and confirm		
8.1	Lubrication tank capacity	Min. 6 ltr.		
9	Following necessary accessories/spares for successful operation of machine, should be provided by vendor	Confirm		
9.1	Proximities & Limit switches	02 Sets		
9.2	CNC Panel Board Keys	02 Sets		
9.3	Oil seals (all sizes)	03 Set		
9.4	O rings	03 set		
9.5	Timing belt	03 Set		
9.6	Wiper dies	02 Set		
9.7	Pressure dies	01 Set		
9.8	Fuses	03 Set		
9.9	Ferrules	03 set		
10	Machine compliance with CE/equivalent norms	Confirm		
B	OTHER CONDITION			
11	Electrical System to be designed for			

11.1	3 Phase, 415V ($\pm 10\%$)	Confirm		
11.2	Frequency: 50 Hz ($\pm 3\%$)	Confirm		
11.3	Protection level	IP54 or better		
12	Complete electrical system with tropicalization for Indian condition +5°C to +50°C temp and RH 100%	Confirm		
13	Service			
13.1	In case of global OEM, the authorized Indian Service Partners must be certified by manufacturer	Confirm		
13.2	Contact person name, address with details such as e-mail, contact no. to be provided by the vendor	Vendor to specify		
14	Additional features			
14.1	Machine to have capability to handle voltage and current fluctuation	Confirm		
14.2	Power backup required for min 15 minutes for CNC control system	Confirm		
15	Separate list of consumable.	Vendor to provide list along with cost		
16	Supplier shall undertake to supply machine spares/accessories up to minimum 10 years from date of supply as appendix-11	Confirm		
17	Vendor to Submit the detail layout of machine	Vendor to submit along with technical details		
18	Documentation: Following documents (3 sets of hard copy and 1 set of soft copy) along with delivery will be required	Confirm		
18.1	Operating instruction	Confirm		
18.2	Installation and Commissioning instructions	Confirm		
18.3	Preventive maintenance instructions	Confirm		
18.4	Lubrication chart & parameter list	Confirm		
18.5	Lifting instruction mentioned in packing list.	Confirm		
18.6	Detailed invoice and packing list of all items and all other accessories enclosed in respective boxes	Confirm		
19	Training at site			
19.1	Operation and Programming	4 Week		
19.2	Preventive maintenance training	1 Week		
20	Prove-out:			
20.1	Vendor to perform complete trial run and prove out	Confirm		
20.2	Vendor has to prove-out on 5 complete sets at ALIMCO premises after installation and commissioning (Refer attached tender drawings).	Confirm		
21	Delivery period including installation and commissioning: within 6 months	Confirm		
22	Vendor to deliver machine at "ALIMCO Kanpur site"	Confirm		
23	Packaging and Transportation is in scope of vendor	Confirm		
24	Installation and Commissioning should be done within 21 days on receipt of machine at site by the vendor. All necessary calibrations shall be done by vendor before handover the machine.	Confirm		
25	DELIVERY PERIOD INCLUDING INSTALLATION & COMMISSIONING:			
25.1	The delivery period including installation & commissioning of the machines at the destination mentioned in Para 1 on page no. 02 of the tender documents will be 06 months from the date of placement of Purchase Order/work contract.	Confirm		
26	WARRANTY			
26.1	The machine inclusive of all system/accessories should be covered under warranty for a period of 24 months from the date of commissioning.	Confirm		
	Note:			
1	Machine shall be supplied with 3 sets of comprehensive operation and maintenance manual.	Confirm		
2	Breakdown calls to be attended within 72 hrs. Physically or within 24 hrs. through tele-diagnostic.	Confirm		

3	Civil foundation details and drawings with specifications to be provided by the tenderer. Vendor to arrange any civil foundation work, if required, for the installation of machine.	Confirm		
4	Total power consumption (in kW) to be provided by the tenderer.	Confirm		
5	The Bus-bar trunking (BBT) line for electricity has been provided at 8.5 meter height. Sufficient suitable cable, cable tray, Circuit breaker, fittings to connect the machine from power source is in Vendor's scope.	Confirm		
6	Compressed air pipeline is available in the work center (Air pressure available will be approx. 4.5 to 6 bar), all necessary fittings, air dryer, air booster as per machine requirements, is in vendor scope.	Confirm		
7	ALIMCO will install machine at a temporary location during first installation. After the new facility is ready, the same will be shifted to that. Vendor to quote separate price for dismantling, re-installation and re-commissioning of machine at new facility. The price to be quoted separately along with price-bid. The order of same will be release separately at ALIMCO discretion (ref. Additional Annexure).	Confirm		
8	Vendor to ensure operation and maintenance training for 7 days, at OEM premises. ALIMCO will bear the cost of travelling, lodging and fooding.	Confirm		
9	Vendor to ensure, to supply additional quantity of oil and lubricants for at-least two more fills along with initial fill.	Confirm		

Tender No – PT/OT/12/AW, Dtd- 12.12.2018

SPECIFIC CONDITIONS OF SUPPLY:

The tenderer should clearly indicate the following in their offer:

- 1) Installation/Commissioning – details,
- 4). Whether DGS&D or any other State/Central Rate Contract exists for the item offered. Please enclose copy.
- 5). Tenders are required to provide address, e-mail, contact person of local service centre/Nearest Service centre from where service support shall be provided.
- 6). Any other relevant technical details of the offered Machine/item/equipment & its accessories.
- 7). Complete details of infrastructural requirement for the offered Machine/item/equipment & its accessories i.e.
Ambient working atmosphere requirement
Power connections requirement.
- 8) Tenderer is required to provide a list of parties with their complete postal address with telephone / e-mail. To whom they have supplied similar Machine/item/equipment over the last 5-8 years. The list should clearly indicate the quantity and the model of the Machine/item/equipment supplied to such customers.
- 9) Tenderer is required to give complete details of the training facilities, if available, with their organization for training our technicians and engineers on the use and maintenance of the Machine/item/equipment & its accessories. Details of complimentary training should also be indicated in the offer.
- 10) Tenderer is required to clearly indicate the details of infrastructure of after sales service facility with its location together with the anticipated time of attending complaints after their receipt of complaint in their service center.
- 11) Tenderer should clearly indicate the reasons as to why they consider their Machine/item/equipment and their offer to be best for supply to the Corporation. The tenderer should enclose all documentary evidence in support of their claim along with their offer.
- 12) The equipments would be required to be supplied and installed in the company premises as specified in Para 1 of the tender document. As such the tenderers should clearly confirm their acceptance to deliver / install and provide after sales service during the warranty period and afterwards at Corporation premises or as the location as specified in the tender document. They are also required to indicate the nearest service point location with address for providing services in respect of the offered Machine/item/equipment.
- 13) In case the tenderer desires to provide supplies of add on optional accessories for the effective functioning of the system on complimentary / chargeable basis, he should clearly indicate items along with the terms of supply. The value of the complimentary supplies proposed should be clearly indicated in the offer.
- 14) The tenderer should **necessarily enclose the complete exhaustive literature / Printed catalogue of their offered Machine/item/equipment & its Accessories** indicating full technical details/specifications and special features of their machine/equipment together with their make & model, etc.

- 15) In case of existence of a **DGS&D /GEM rate contract or a State/Central Govt. Rate Contract** in respect of the supply of the offered machine/equipment, an authenticated copy of the same should also be enclosed along with the offer. The enclosing of a copy of the relevant rate contract would still permit the tenderer to submit a lower competitive offer in which case the corporation would consider only the lower offer for comparison and analysis.
- 16) The tenderers are required to submit exhaustive (anticipated) list of spares likely to be used on chargeable basis during the period of 03 years together with their prices indicating validity period of each spares for our necessary reference and records.
- 18) In case of any problem / trouble / defect after commissioning the local service provider is required to respond / attend the problem within 48 Hrs.
- 19) The repeat orders may be placed up to 100% of quantity of original order where the original order was placed on the supplier selected on the basis of ST/OT/LT/ team purchase only for ordering additional quantity. The repeat order will be placed on same rates and terms as mentioned in initial order.

FORMAT FOR BANK GUARANTEE TOWARDS SECURITY DEPOSIT/PERFORMANCE GUARANTEE

(To be executed by any Nationalised Bank in India, on a Rs. 200 non-judicial stamp paper under bank's covering letter mentioning address of the bank)

In consideration of M/s Artificial Limbs Manufacturing Corporation of India, hereinafter referred to as 'ALIMCO', which expression unless repugnant to the context and meaning thereof shall include its successors and assigns having agreed to exempt M/s _____ (Name of the vender/supplier/contractor) hereinafter referred to as supplier/contractor which expression unless repugnant to the context and meaning thereof shall include its successors and assigns] from depositing with ALIMCO a sum of Rs. _____ towards security / performance guarantee in lieu of the said supplier/contractor having agreed to furnish a bank guarantee for the said sum of Rs. _____ as required under the terms and conditions of contract / work order / purchase order no. _____ dated _____ [hereinafter referred as the order'] placed by ALIMCO on the said supplier / contractor.

We, _____ the bank [hereinafter referred to as 'the bank' which expression shall include Its successors and assigns] do hereby undertake to pay ALIMCO an amount not exceeding Rs. _____ on the demand made by ALIMCO on us due to a breach committed by the said supplier / contractor of the terms and conditions of the order.

We _____ the bank hereby undertakes to pay the amount under the guarantee without any demur merely on a demand from ALIMCO stating that there is a breach by the supplier / contractor of any of the terms and conditions contained in the order or by the reasons of the supplier's / contractor's failure to comply with the terms and conditions as stipulated in the order or amendment(s) thereto.

The demand made on the bank shall be conclusive as to the breach of the terms and conditions of the order and as regard to the amount due and payable by the bank under this guarantee, notwithstanding any dispute or disputes raised by the said supplier / contractor regarding the validity of such breach and we agree to pay the amount so demanded by ALIMCO without any demur. However, our liability under this guarantee shall be restricted to an amount not exceeding Rs. _____.

We, _____ the bank further agree that the guarantee herein contained shall remain in full force and effect during the period that would be taken for the performance of the said order and that it shall continue to be enforceable till the dues of ALIMCO under or by virtue of the said order have been fully paid and its claim satisfied or discharged or till ALIMCO certifies that the terms and conditions of the order have been fully and properly carried out by the supplier / contractor and accordingly discharge the guarantee.

We _____ the bank, undertake to pay to ALIMCO any money so demanded notwithstanding any dispute or disputes raised by the said supplier / contractor in any suit or proceedings pending before any court or tribunal relating thereto as our liability under this present being absolute and unequivocal. The payment so made by us under this bond shall be valid discharge of our liability for payment there under and the said supplier / contractor shall have no claim against us for making such payment.

We _____ the bank further agree that ALIMCO shall have full liberty, without our consent and without affecting in any manner our obligation hereunder to vary any of the terms and conditions of the order or to extend time of performance by the said supplier / contractor from time to time or to postpone for any time or from time to time any of the powers exercisable by the ALIMCO against the said supplier / contractor and to forbear or enforce any of the terms and conditions relating to the order and shall not be relieved from our liability by reason of any such variation or extension being granted to the said supplier / contractor or for any forbearance, act or omission on the part of ALIMCO or any indulgence by ALIMCO to the supplier / contractor or by any such matter or thing whatsoever which under the law relating to sureties would but for this provisions have effect of so relieving us. Our liability under this guarantee is restricted to Rs. _____ and shall remain in force up to _____ unless demand or claim under this guarantee is made on us in writing within 3 months from the date of expiry viz. _____. We shall be discharged from all liabilities under this guarantee thereafter.

This guarantee will not discharged due to change in the constitution in the bank or the said supplier / contractor.

The bank hereby agrees to address all the future correspondence in regard to this bank guarantee to Chairman & Managing Director, Artificial Limbs Manufacturing Corporation of India.

We, _____ the bank lastly undertake not to revoke this guarantee during its currency except with the previous consent of ALIMCO in writing.

Signed on the _____ day of

Witness

**Signature
For the Bank**

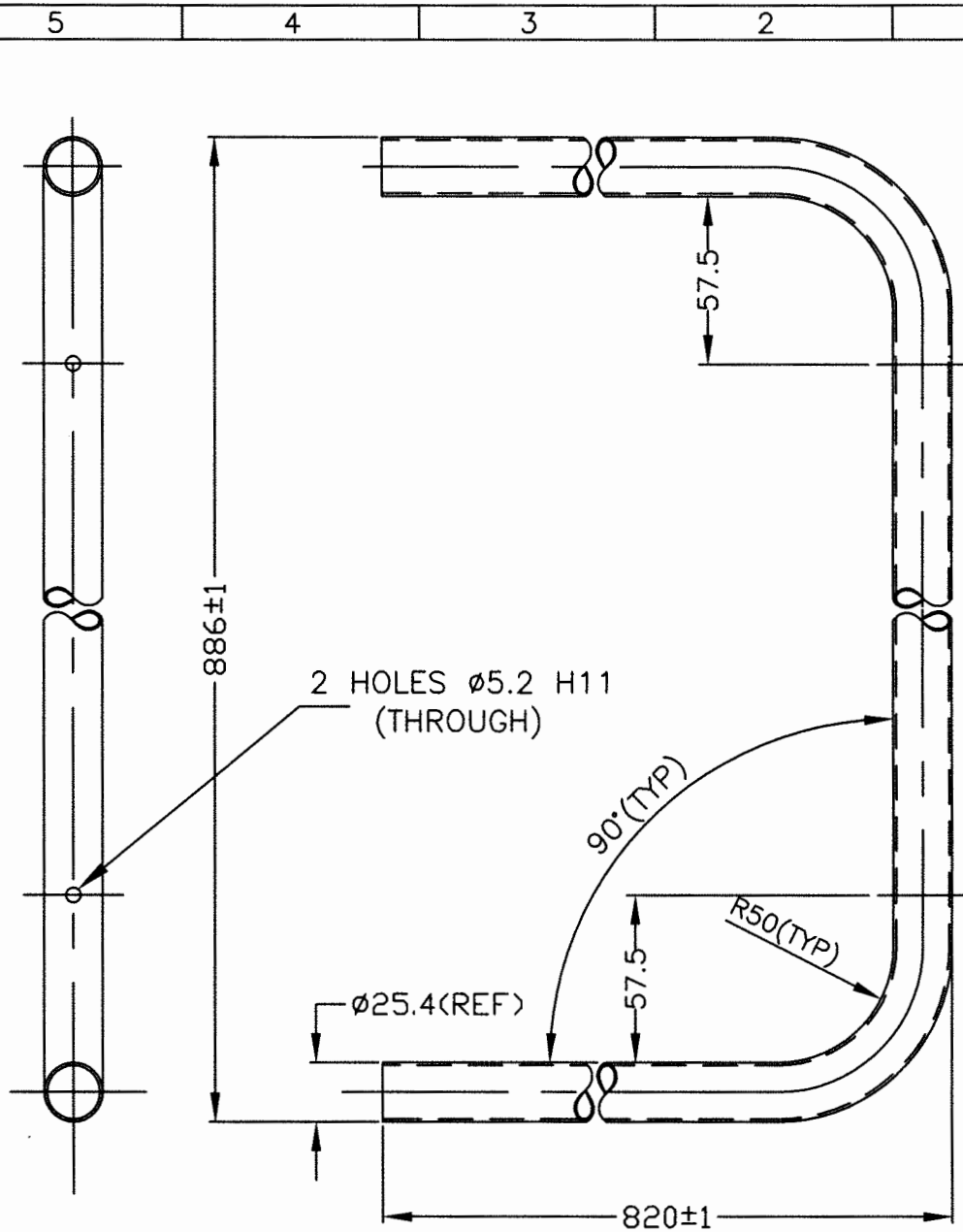

NOTE:-

1. REMOVE SHARP EDGES & CORNERS

4	—	DIMS 57.5 & 2 HOLES ϕ 5.2H11 ADDED	14.08.15	<i>[Signature]</i>
3	—	DRAWING REDRAWN	2.5.13	<i>[Signature]</i>
SNo.	REGION	REVISION	DATE	SIGN

REVISIONS



ARTIFICIAL LIMBS
MANUFACTURING CORPORATION
OF INDIA
KANPUR



DGN	<i>[Signature]</i>	NOM	REAR LOOP	
DRN	<i>[Signature]</i>	MTL	STEEL TUBE ERW C1 OD25.4mm THICK1.25mm ANNEALED IS:2039(AF60)	
CHD	<i>[Signature]</i>	TOL	INTEGER ONLY \pm 0.500 mm ONE PLACE DECIMAL \pm 0.250 mm TWO PLACE DECIMAL \pm 0.126 mm	UNLESS SPECIFIED
DIM	IN mm	FIN		
SCALE	NTS ϕ \square			
APP	<i>[Signature]</i>	DRG No:-	TD 2 C 98 J 01	SHEET
DATE	02.03.1994			

01 J 03 001

5

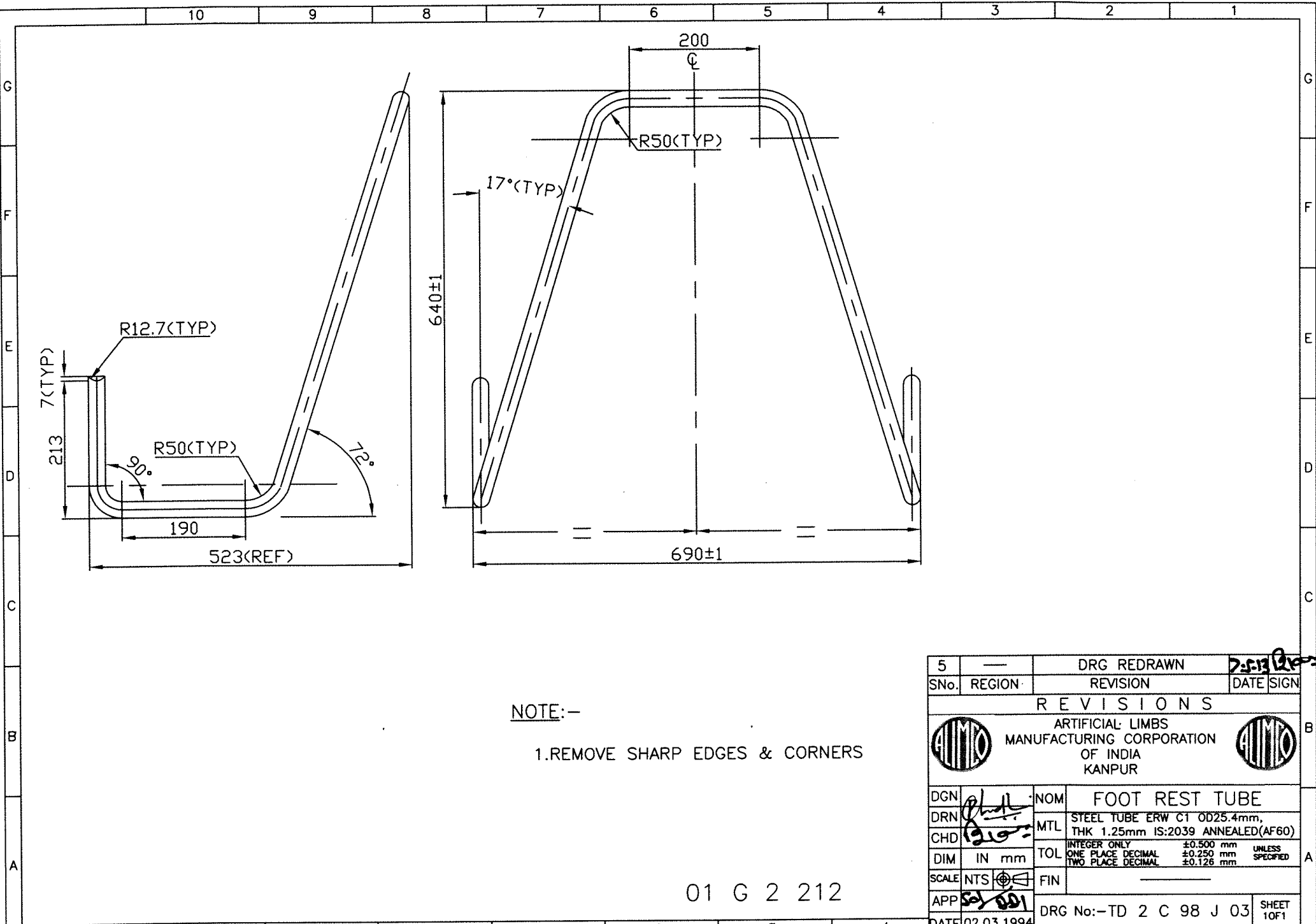

4



NOTE:--

1.REMOVE SHARP EDGES & CORNERS

01 G 2 212

5	—	DRG REDRAWN	2.5.13
SNo.	REGION	REVISION	DATE SIGN
REVISIONS			
		ARTIFICIAL LIMBS MANUFACTURING CORPORATION OF INDIA KANPUR	
			
DGN	PHD	NOM	FOOT REST TUBE
DRN	PHD	MTL	STEEL TUBE ERW C1 OD25.4mm, THK 1.25mm IS:2039 ANNEALED(AF60)
CHD	PHD	TOL	INTEGER ONLY ±0.500 mm UNLESS SPECIFIED ONE PLACE DECIMAL ±0.250 mm TWO PLACE DECIMAL ±0.126 mm
DIM	IN mm	FIN	
SCALE	NTS		
APP	SD		
DATE	02.03.1994	DRG No:--TD 2 C 98 J 03	SHEET 10F1

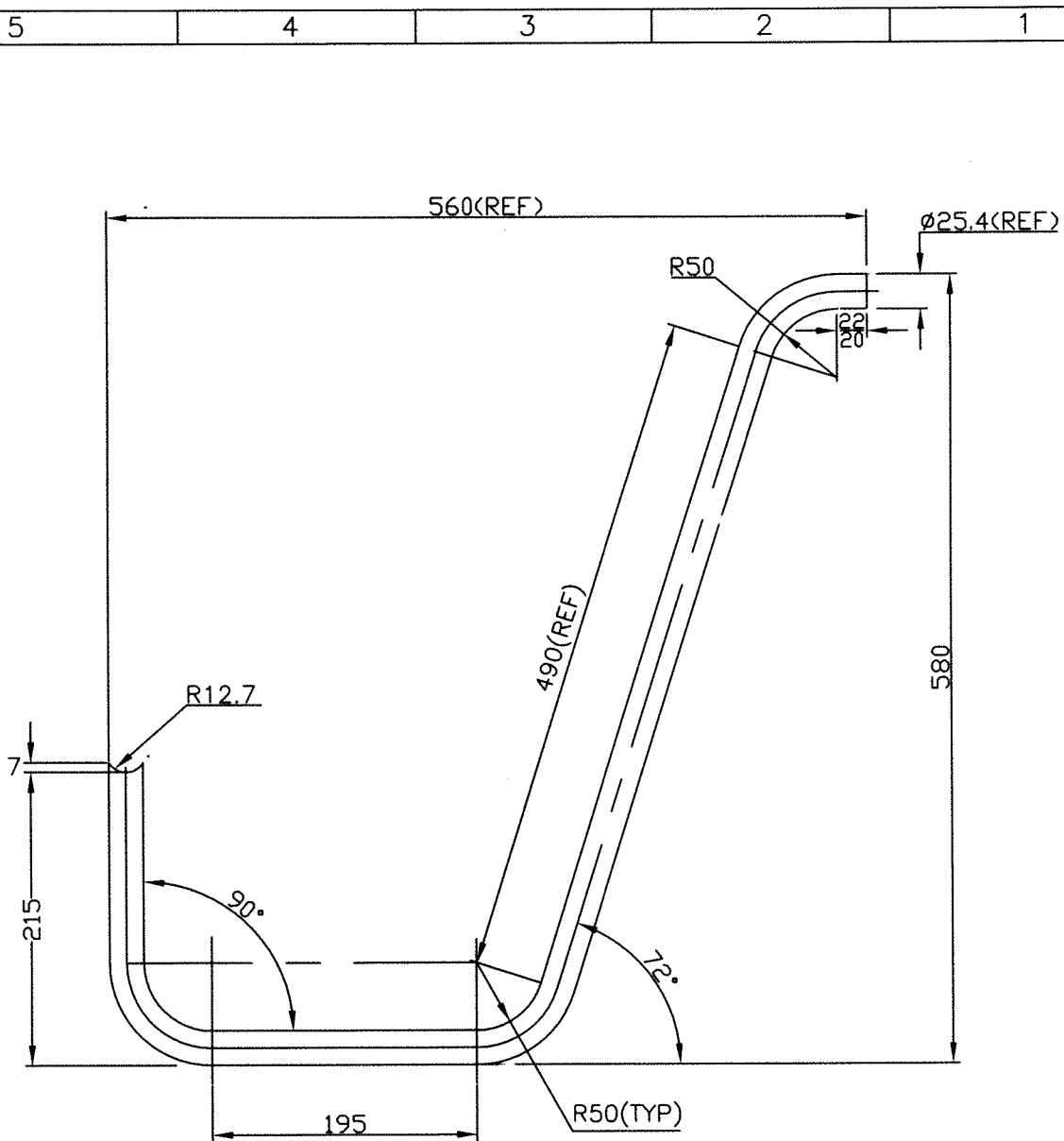

NOTE:-

1.REMOVE SHARP EDGES & CORNERS

4	—	DRAWING REDRAWN	25.13	Q101
SNo.	REGION	REVISION	DATE	SIGN
R E V I S I O N S				
		ARTIFICIAL LIMBS MANUFACTURING CORPORATION OF INDIA KANPUR		
DGN	<i>Chudh</i>	NOM	CENTRAL TUBE	
DRN	<i>Papir</i>	MTL	STEEL TUBE ERW C1 OD25.4mm THICK1.25mm ANNEALED IS:2039(AF60)	
CHD		TOL	INTEGER ONLY ±0.500 mm	UNLESS SPECIFIED
DIM	IN mm		ONE PLACE DECIMAL ±0.250 mm	
			TWO PLACE DECIMAL ±0.126 mm	
SCALE	NTS	FIN		
APP	<i>Sel</i>	DATE	DRG No:-TD 2 C 98 J 04	SHEET 10F1
			02.03.1994	

01 J 03 003

5

4

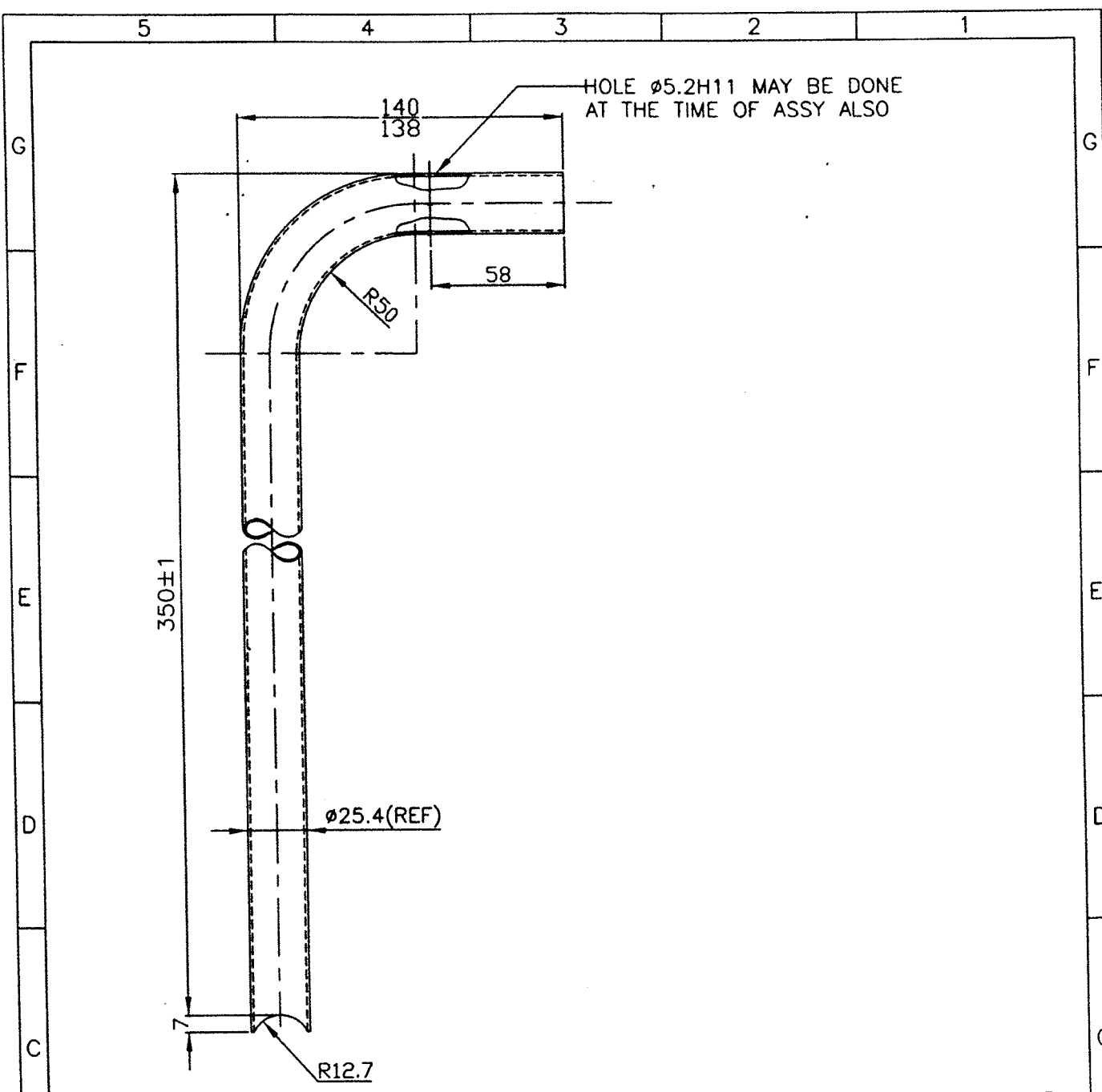

HOLE $\phi 5.2H11$ MAY BE DONE AT THE TIME OF ASSY ALSO

NOTE:-
1. REMOVE SHARP EDGES & CORNERS

7	E-5	DIM 350±1 WAS 355±1	10.7.14	<i>[Signature]</i>
6	—	DRAWING REDRAWN	7.5.13	<i>[Signature]</i>
SNo.	REGION	REVISION	DATE	SIGN

REVISIONS



ARTIFICIAL LIMBS
MANUFACTURING CORPORATION
OF INDIA
KANPUR



DGN	<i>[Signature]</i>	NOM	LOOP SUPPORT TUBE	
DRN	<i>[Signature]</i>	MTL	STEEL TUBE ERW C1 OD25.4mm, THICK1.25mm ANNEALED IS:2039(AF60)	
CHD	<i>[Signature]</i>	TOL	INTEGER ONLY ±0.500 mm ONE PLACE DECIMAL ±0.250 mm TWO PLACE DECIMAL ±0.126 mm	UNLESS SPECIFIED
DIM	IN mm	FIN	—	
SCALE	NTS			
APP	<i>[Signature]</i>	DRG No.:-	TD 2 C 98 J 05	SHEET 10F1
DATE	02.03.1994			

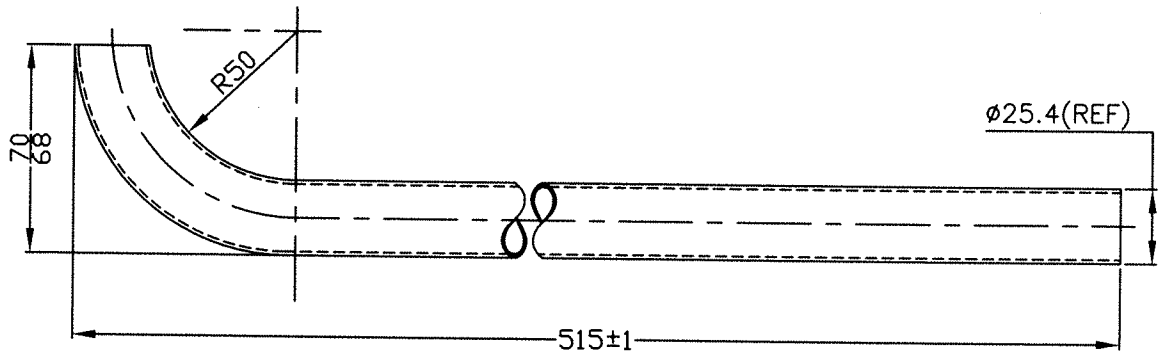

01 J 03 004

5 4



NOTE:-

1.REMOVE SHARP EDGES & CORNERS

4	—	DRAWING REDRAWN	7.5.13	<i>[Signature]</i>
SNo.	REGION	REVISION	DATE	SIGN
R E V I S I O N S				
		ARTIFICIAL LIMBS MANUFACTURING CORPORATION OF INDIA KANPUR		
				
DGN	<i>Check</i>	NOM	SIDE SUPPORT TUBE	
DRN	<i>[Signature]</i>	MTL	STEEL TUBE ERW C1 OD25.4mm, THICK1.25mm ANNEALED IS:2039(AF60)	
CHD	<i>[Signature]</i>	TOL	INTEGER ONLY ±0.500 mm ONE PLACE DECIMAL ±0.250 mm TWO PLACE DECIMAL ±0.126 mm UNLESS SPECIFIED	
DIM	IN mm	FIN		
SCALE	NTS			
APP	<i>Sd. [Signature]</i>	DRG No:-TD 2 C 98 J 06		SHEET 10F1
DATE	02.03.1994			

01 J 03 005

5

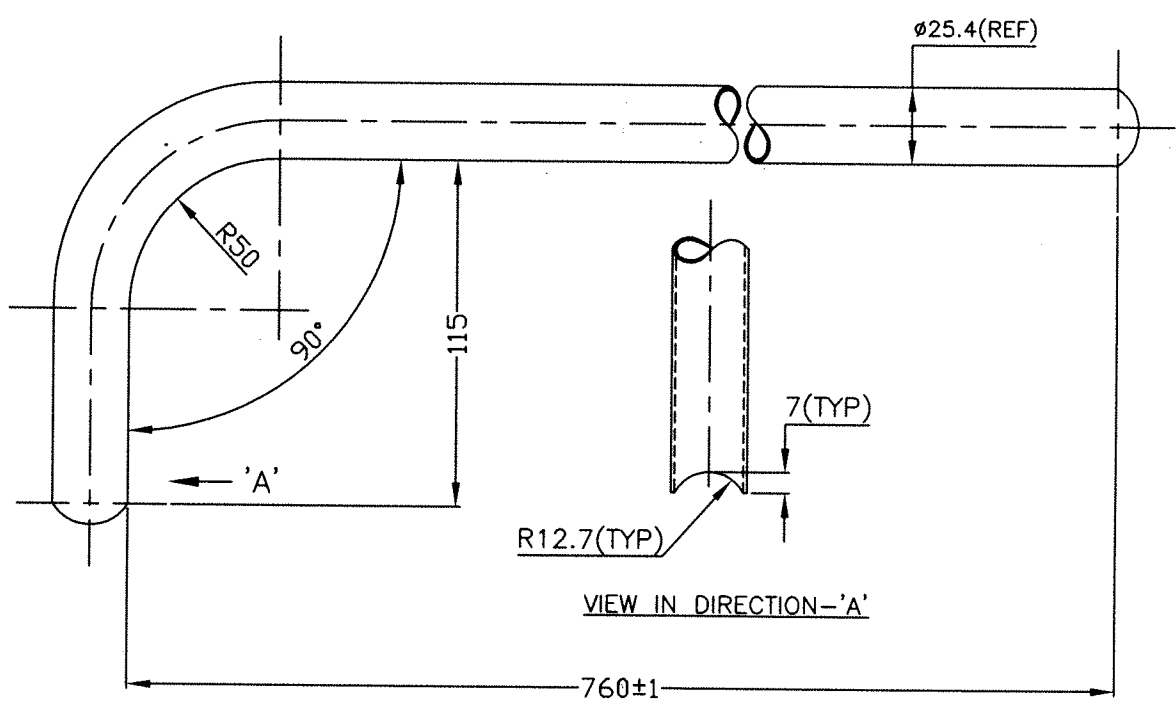

4



NOTE:-
1. REMOVE SHARP EDGES & CORNERS

4	—	DRAWING REDRAWN	7.5.13	<i>[Signature]</i>
SNo.	REGION	REVISION	DATE	SIGN

R E V I S I O N S

ARTIFICIAL LIMBS
MANUFACTURING CORPORATION
OF INDIA
KANPUR

DGN	<i>[Signature]</i>	NOM	REAR LOOP MEMBER	
DRN	<i>[Signature]</i>	MTL	STEEL TUBE ERW C1 OD25.4mm, THICK1.25mm ANNEALED IS:2039(AF60)	
CHD	<i>[Signature]</i>	TOL	INTEGER ONLY ±0.500 mm ONE PLACE DECIMAL ±0.250 mm TWO PLACE DECIMAL ±0.126 mm	UNLESS SPECIFIED
DIM	IN mm	FIN	—	
SCALE	NTS		—	
APP	<i>[Signature]</i>		—	

01 J 03 007

DATE	02.03.1994	DRG No:-	TD 2 C 98 J 08	SHEET	10F1
------	------------	----------	----------------	-------	------

5

4

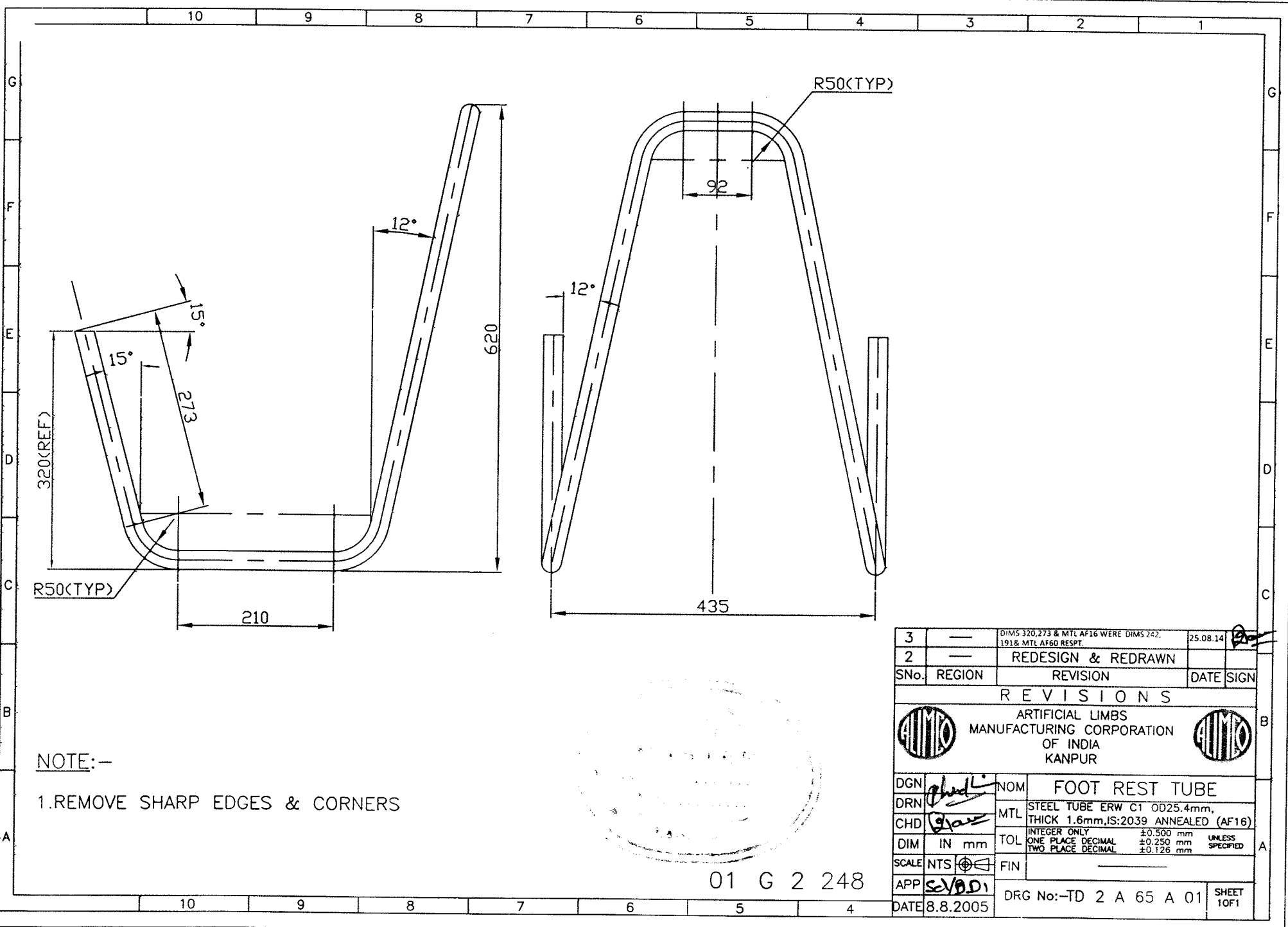

NOTE:--
 1.REMOVE SHARP EDGES & CORNERS



01 G 2 248

3	---	DIMS 320,273 & MTL AF16 WERE DIMS 242, 191& MTL AF60 RESPT.	25.08.14	
2	---	REDESIGN & REDRAWN		
SNo. REGION		REVISION	DATE	SIGN
REVISIONS				
		ARTIFICIAL LIMBS MANUFACTURING CORPORATION OF INDIA KANPUR		
DGN		NOM	FOOT REST TUBE	
DRN		MTL	STEEL TUBE ERW C1 OD25.4mm, THICK 1.6mm,IS:2039 ANNEALED (AF16)	
CHD		TOL	INTEGER ONLY ±0.500 mm ONE PLACE DECIMAL ±0.250 mm TWO PLACE DECIMAL ±0.126 mm	
DIM	IN mm	FIN	UNLESS SPECIFIED	
SCALE	NTS			
APP				
DATE	8.8.2005	DRG No.:-TD 2 A 65 A 01	SHEET 10F1	

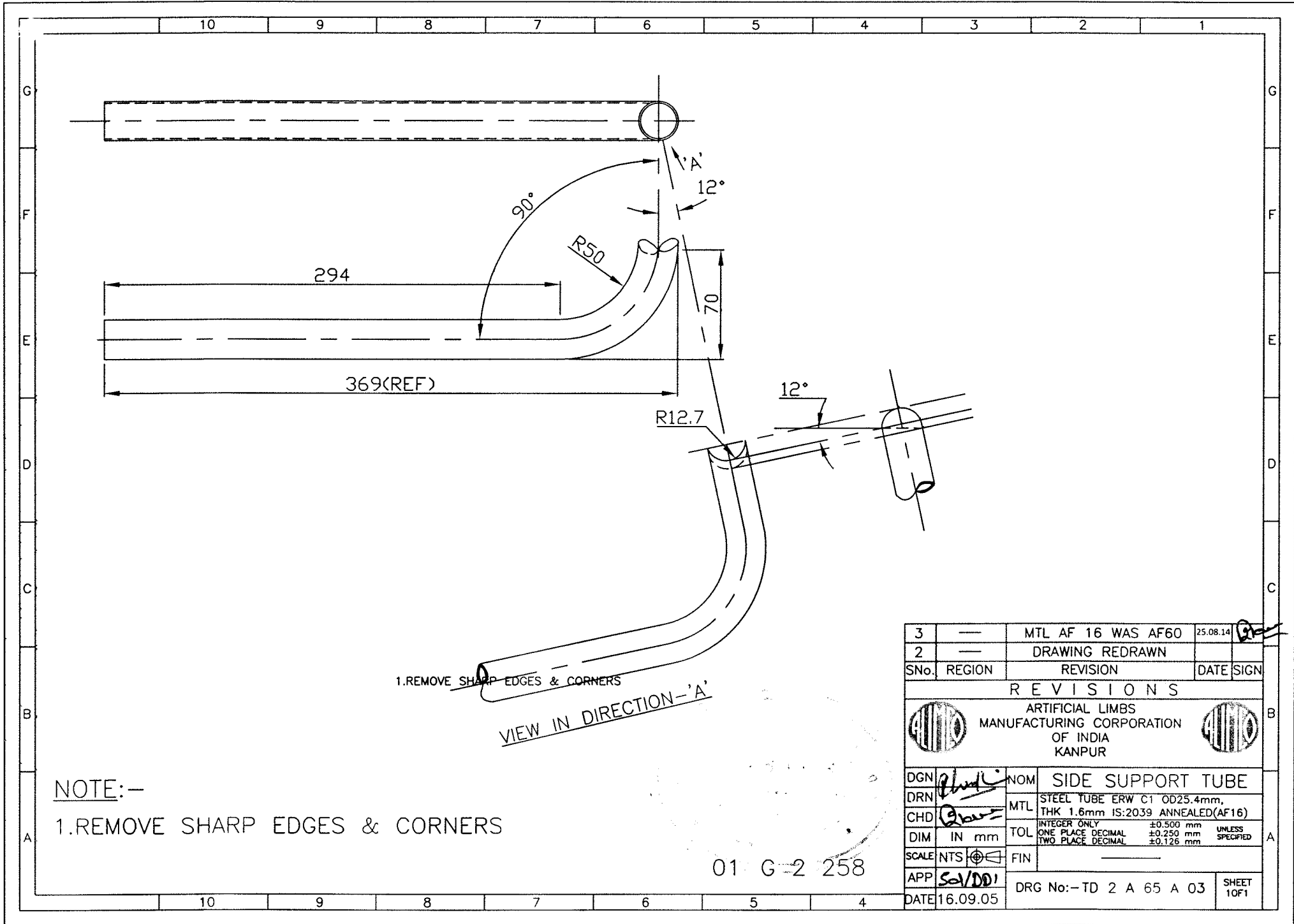

1.REMOVE SHARP EDGES & CORNERS
 VIEW IN DIRECTION-'A'

NOTE:-
 1.REMOVE SHARP EDGES & CORNERS

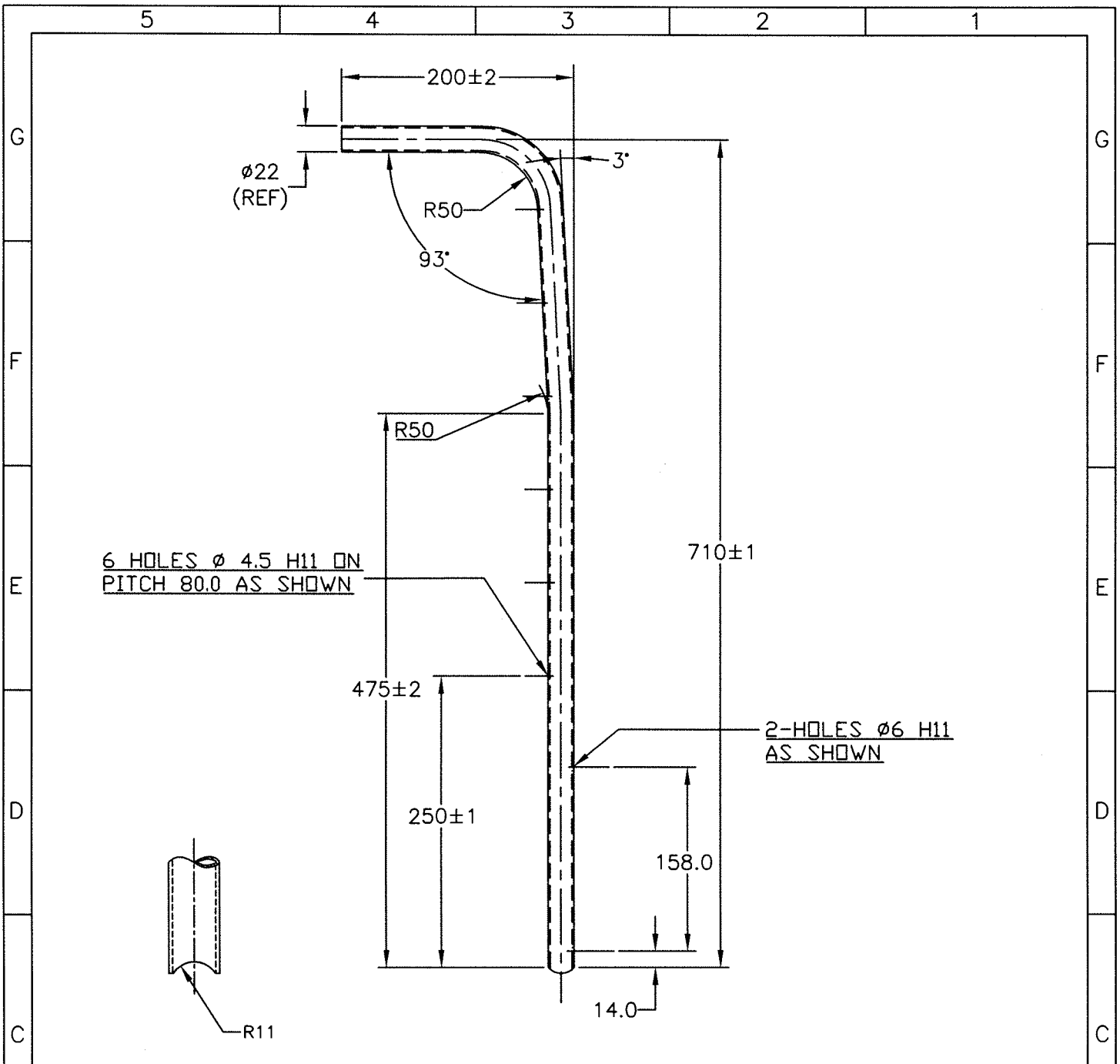

01 G-2 258

3	---	MTL AF 16 WAS AF60	25.08.14	
2	---	DRAWING REDRAWN		
SNo.	REGION	REVISION	DATE	SIGN
REVISIONS				
ARTIFICIAL LIMBS MANUFACTURING CORPORATION OF INDIA KANPUR				
DGN		NOM	SIDE SUPPORT TUBE	
DRN		MTL	STEEL TUBE ERW C1 OD25.4mm, THK 1.6mm IS:2039 ANNEALED(AF16)	
CHD		TOL	INTEGER ONLY ±0.500 mm ONE PLACE DECIMAL ±0.250 mm TWO PLACE DECIMAL ±0.125 mm UNLESS SPECIFIED	
SCALE	NTS	FIN		
APP		DRG No.:-	TD 2 A 65 A 03	SHEET 10F1
DATE	16.09.05			



NOTE:-

1.REMOVE SHARP EDGES & CORNERS.

1.	---	DRAWING REDRAWN	03.12.14	<i>Ri</i>
SNo.	REGION	REVISION	DATE	SIGN
R E V I S I O N S				
 ARTIFICIAL LIMBS MANUFACTURING CORPORATION OF INDIA KANPUR 				
DGN		NOM	TUBE REAR	
DRN	<i>Ashish</i>	MTL	STEEL TUBE ERW-C1 OD 22.23mm THICK 1.6mm IS:2039, ANNEALED (AF13)	
CHD	<i>Ri</i>	TOL	INTEGER ONLY ±0.500 mm ONE PLACE DECIMAL ±0.250 mm TWO PLACE DECIMAL ±0.126 mm UNLESS SPECIFIED	
DIM	<i>in mm</i>	FIN	---	
SCALE	NTS			
APP	<i>Scl/DD1</i>			
DATE	25.09.1982		DRG No:-TD 2 C 51 A 01	
			SHEET 10F1	

01	K	5	160
5		4	

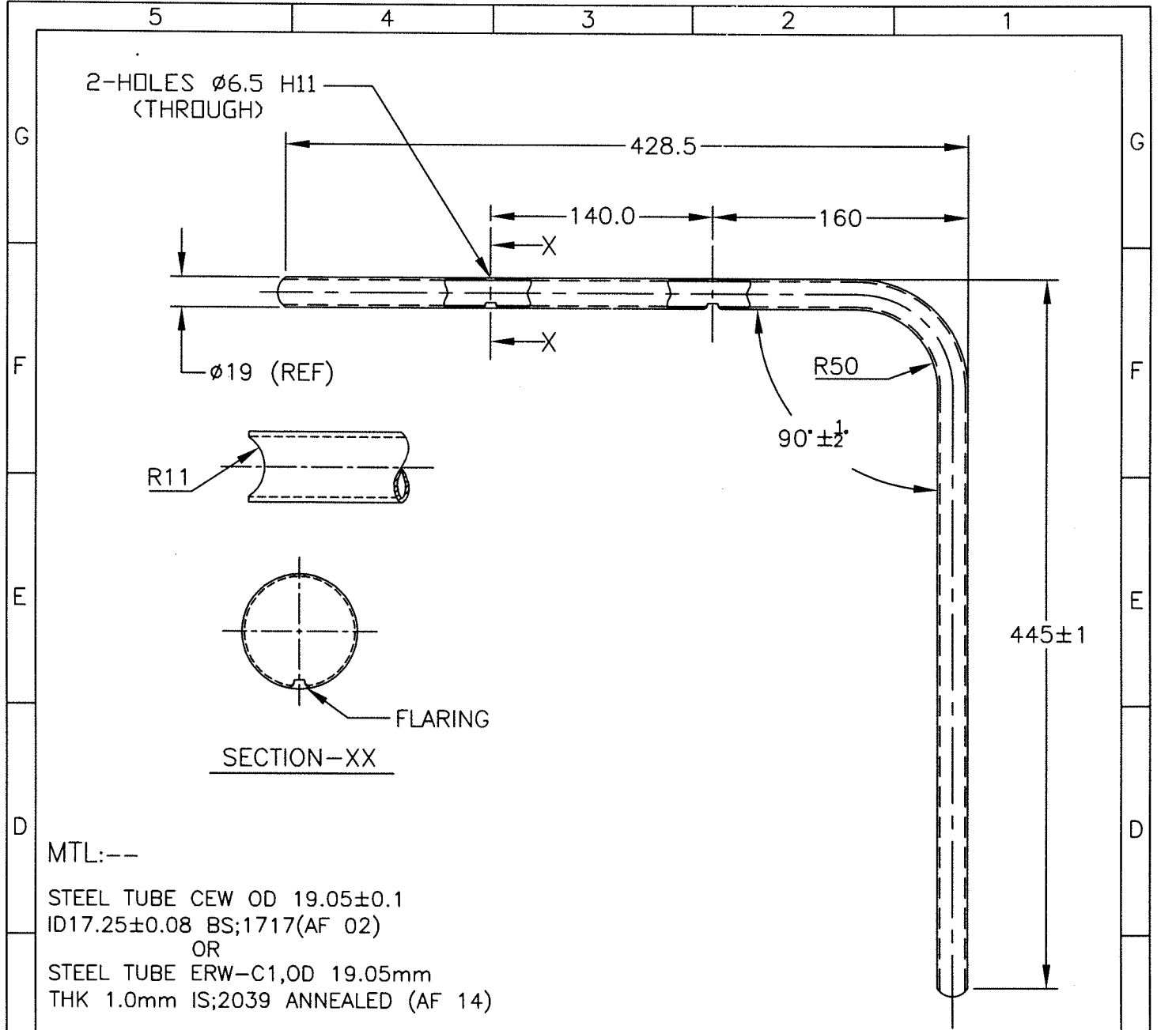

MTL:---

STEEL TUBE CEW OD 19.05±0.1
 ID 17.25±0.08 BS;1717(AF 02)
 OR
 STEEL TUBE ERW-C1, OD 19.05mm
 THK 1.0mm IS;2039 ANNEALED (AF 14)

NOTE:---

1. REMOVED SHARP EDGES & CORNERS.
2. DRILL 2-HOLES $\phi 6.5H11$ & FLARE UP TO PROVIDE C'BORE FOR CSK HEAD SCREW.
3. AXIS OF HOLES TO BE IN THE PLANE OF TUBE WITH IN $\pm 2^\circ$.

15.	---	DRAWING REDRAWN	03.12.14	<i>[Signature]</i>
SNo.	REGION	REVISION	DATE	SIGN

REVISIONS

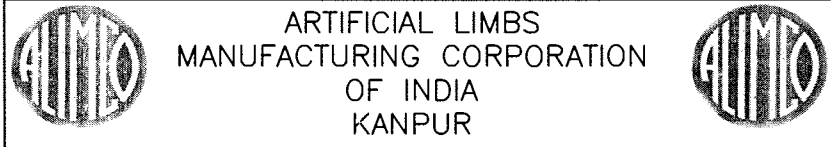

ARTIFICIAL LIMBS
 MANUFACTURING CORPORATION
 OF INDIA
 KANPUR

DGN		NOM	TUBE ARM REST	
DRN	<i>Ashish</i>	MTL	INDICATED	
CHD	<i>[Signature]</i>	TOL	INTEGER ONLY	±0.500 mm
DIM	IN mm		ONE PLACE DECIMAL	±0.250 mm
SCALE	NTS		TWO PLACE DECIMAL	±0.126 mm
APP	<i>[Signature]</i>	FIN	UNLESS SPECIFIED	

01	K	5	161
5		4	

DATE	25.09.1982	DRG No:--TD 2 C 51 A 02	SHEET 10F1
------	------------	-------------------------	------------

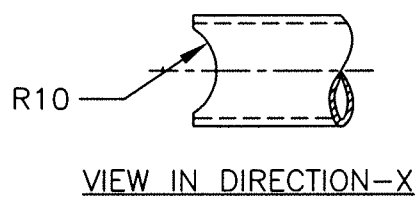
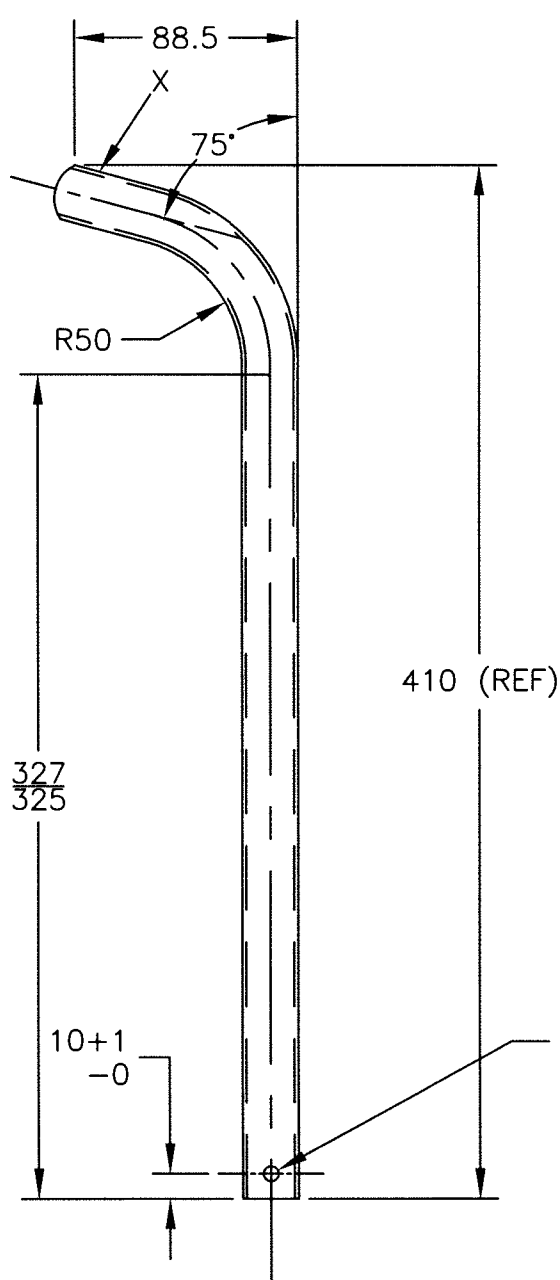

NOTE:--
1. REMOVE SHARP EDGES & CORNERS.

17.	---	DRAWING REDRAWN	14.01.15	<i>Sign</i>
SNo.	REGION	REVISION	DATE	SIGN

REVISIONS

ARTIFICIAL LIMBS
 MANUFACTURING CORPORATION
 OF INDIA
 KANPUR

DGN		NOM	TUBE MAIN FOOT REST SUPPORT	
DRN	<i>Ashish</i>	MTL	STEEL TUBE ERW-C1 OD 22.23mm	
CHD	<i>Shaw</i>		THK 1.6mm IS:2039 ANNEALED(AF13)	
DIM	IN mm	TOL	INTEGER ONLY	±0.500 mm
			ONE PLACE DECIMAL	±0.250 mm
SCALE	NTS	FIN		UNLESS SPECIFIED
APP	<i>Sa/DD1</i>	DRG No:--TD 2 A 02 A 05		SHEET 10F1
DATE	26.05.1978			

01	K	5	003
5			4

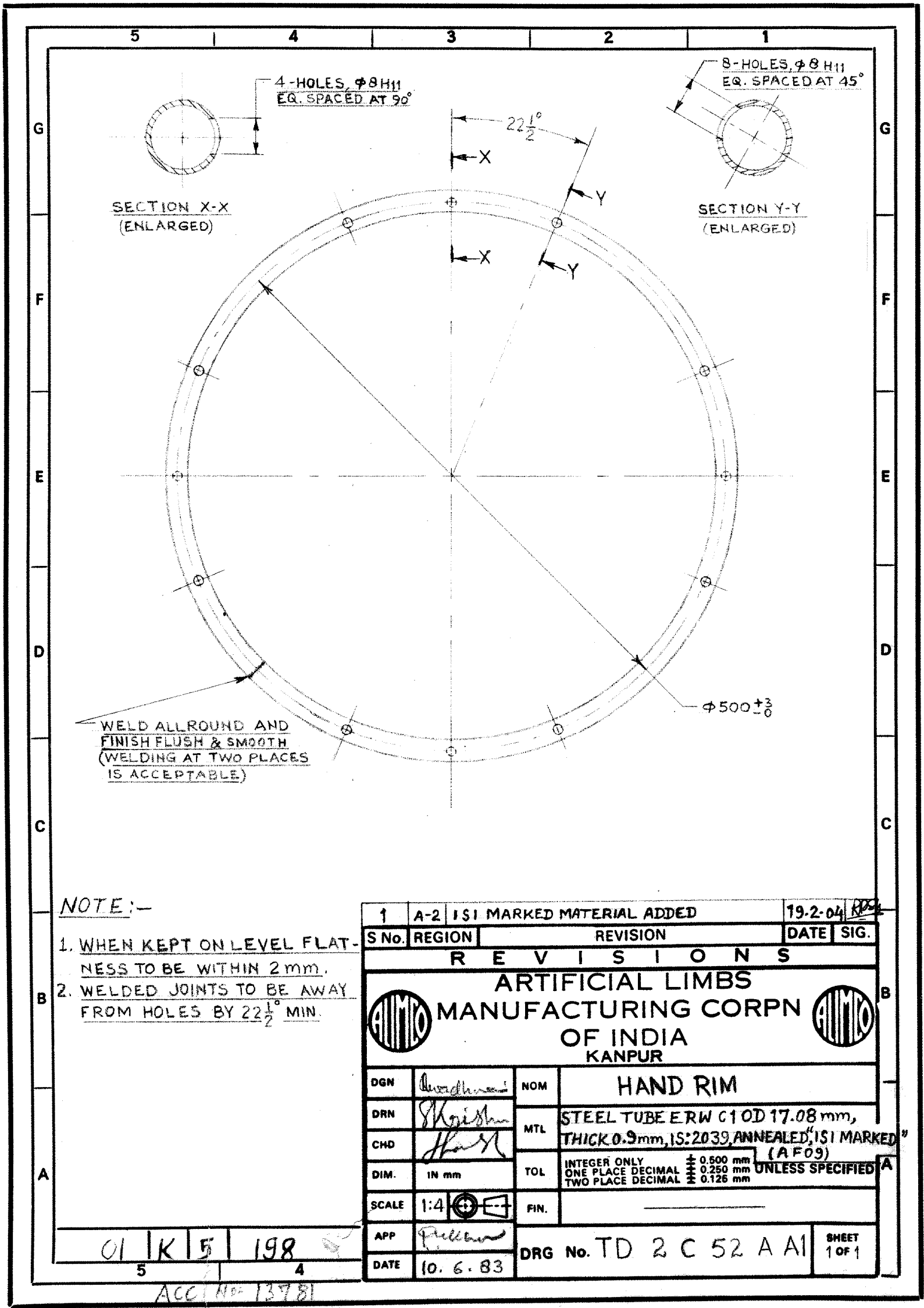

NOTE:-



1. WHEN KEPT ON LEVEL FLATNESS TO BE WITHIN 2 mm.
2. WELDED JOINTS TO BE AWAY FROM HOLES BY $22\frac{1}{2}^\circ$ MIN.

1	A-2	ISI MARKED MATERIAL ADDED	19.2.04	<i>RSK</i>
S No.	REGION	REVISION	DATE	SIG.
R E V I S I O N S				
ARTIFICIAL LIMBS				
MANUFACTURING CORPN				
OF INDIA				
KANPUR				
DGN	<i>Aradhana</i>	NOM	HAND RIM	
DRN	<i>Shrishan</i>	MTL	STEEL TUBE ERW C1 OD 17.08 mm,	
CHD	<i>Harsh</i>	TOL	THICK 0.9 mm, IS: 2039, ANNEALED, ISI MARKED (AF09)	
DIM.	IN mm	TOL	INTEGER ONLY ± 0.500 mm ONE PLACE DECIMAL ± 0.250 mm TWO PLACE DECIMAL ± 0.125 mm UNLESS SPECIFIED	
SCALE	1:4	FIN.		
APP	<i>Pillay</i>	DRG No.	TD 2 C 52 A A1	SHEET 1 OF 1
DATE	10.6.83			

01 | K | 5 | 198

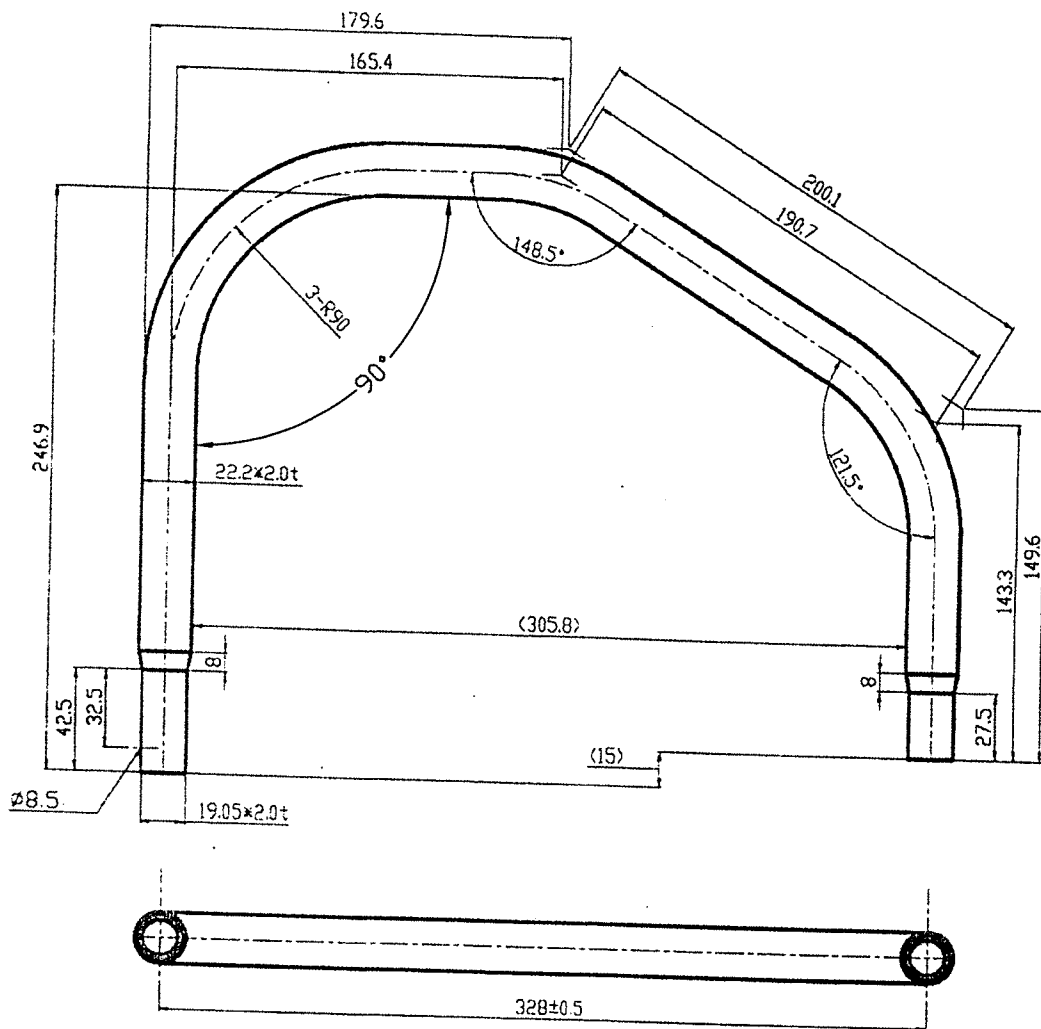
ACC No: 13781



SNo.	REGION	REVISION	DATE	SIGN
REVISIONS				
 ARTIFICIAL LIMBS MANUFACTURING CORPORATION OF INDIA KANPUR 				
DGN	ASHISH	NOM	ARM REST TUBE CURVED	
DRN		MTL	ALUMINIUM 6063 - T6 (BENDING QUALITY)	
CHD	SHIV PAL	HEAT TREATMENT	_____	
DIM	IN mm	SURFACE TREATMENT	_____	
SCALE	NTS 			
APP	VISHAL	DRG No:- TD 2 B 36 E 01	REV	SHEET
DATE	15.01.2018		0	1 OF 1

Tolerance wherever not specified

Dim	Tolerance Range		
1 - 16	± 0.2	± 0.3	± 0.4
17 - 63	± 0.2	± 0.5	± 0.7
64 - 250	± 0.3	± 0.7	± 1.0
250 - 960	± 0.5	± 0.12	± 1.5

5 4 3 2 1

G

G

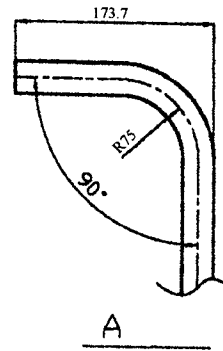
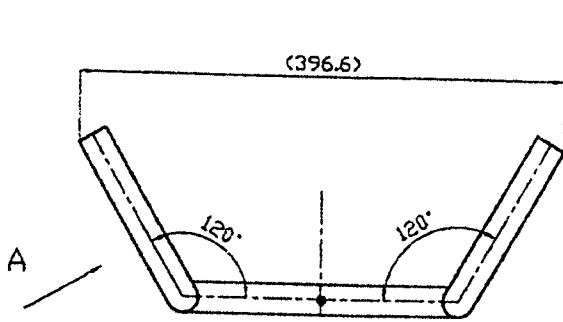

F

F

E

E

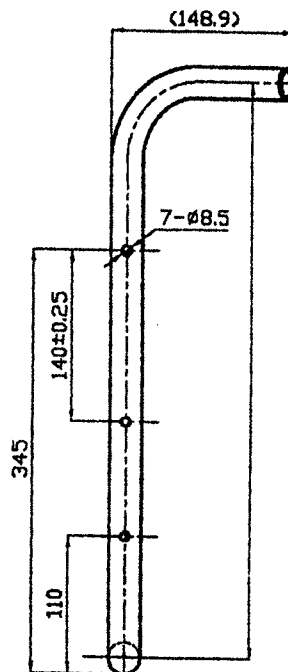
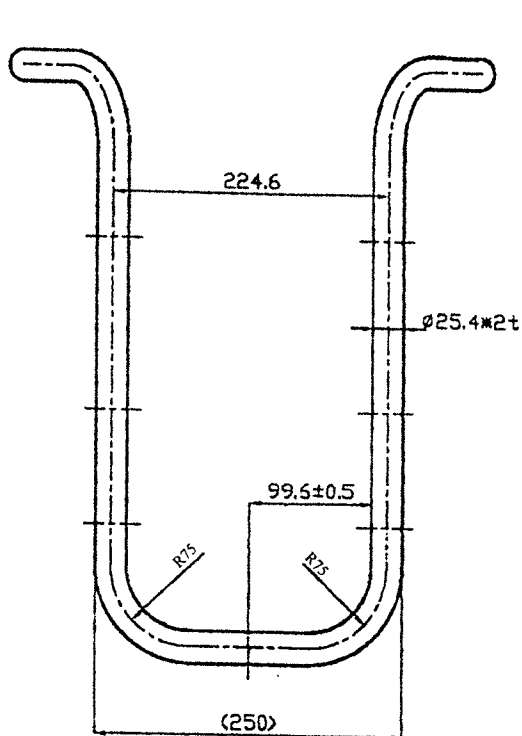

D

D

C

C

B

B

SNo.	REGION	REVISION	DATE	SIGN
------	--------	----------	------	------

REVISIONS



ARTIFICIAL LIMBS
MANUFACTURING CORPORATION
OF INDIA
KANPUR



DGN	ASHISH	NOM	PUSH HANDLE TUBE	
DRN	SHIV PAL	MTL	ALUMINIUM 6063 - T6 (BENDING QUALITY)	
DIM	IN mm	HEAT TREATMENT	_____	
SCALE	NTS	SURFACE TREATMENT	_____	
APP	VISHAL	DRG No:- TD 2 B 36 D 01	REV 0	SHEET 1 OF 1
DATE	15.01.2018			

Tolerance wherever not specified

Dim	Tolerance Range		
1 - 16	± 0.2	± 0.3	± 0.4
17 - 63	± 0.2	± 0.5	± 0.7
64 - 250	± 0.3	± 0.7	± 1.0
250 - 960	± 0.5	± 0.12	± 1.5

5

4

A

A

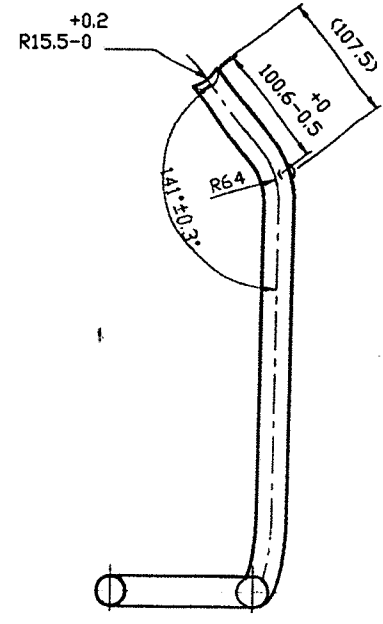
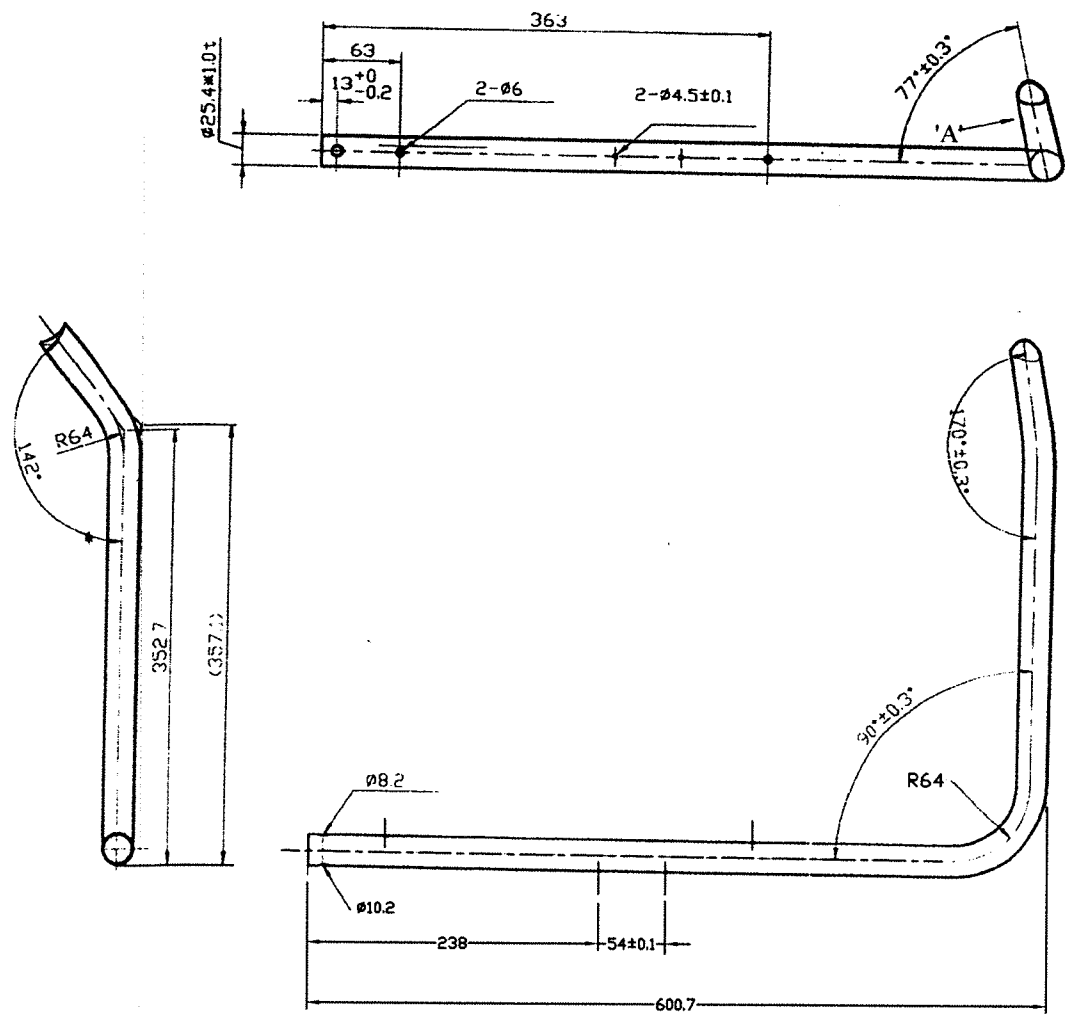

VIEW IN DIRECTION 'A'

Tolerance wherever not specified

Dim	Tolerance Range		
1 - 16	± 0.2	± 0.3	± 0.4
17 - 63	± 0.2	± 0.5	± 0.7
64 - 250	± 0.3	± 0.7	± 1.0
250 - 960	± 0.5	± 0.12	± 1.5

SNo.	REGION	REVISION	DATE	SIGN
REVISIONS				
ARTIFICIAL LIMBS MANUFACTURING CORPORATION OF INDIA KANPUR				
DGN	ASHISH	NOM	BACK REST TUBE - L	
DRN	SHIV PAL	MTL	STEEL TUBE ERWI, IS:3074 Ø 25.4x1mm THICK	
CHD	SHIV PAL	HEAT	TREATMENT	
DIM	IN mm	SURFACE	TREATMENT	
SCALE	NTS	TREATMENT		
APP	VISHAL	DRG No:- TD 2 B 37 B A1		
DATE	09.02.2018	REV	0	SHEET 1 OF 1

5 4 3 2 1

G G

F F

E E

D D

C C

B B

A A

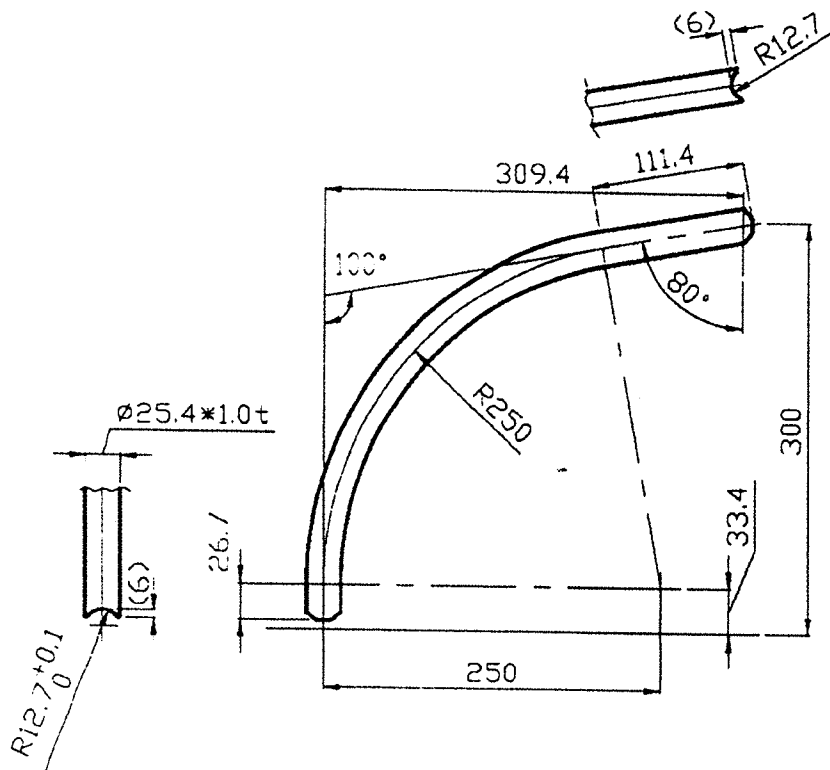

SNo.	REGION	REVISION	DATE	SIGN
------	--------	----------	------	------

REVISIONS



**ARTIFICIAL LIMBS
MANUFACTURING CORPORATION
OF INDIA
KANPUR**



DGN	ASHISH	NOM	ARM REST TUBE	
DRN		MTL	STEEL TUBE ERW1, IS:3074, Ø25.4x1mm THICK	
CHD	SHIV PAL	HEAT TREATMENT	_____	
DIM	IN mm	SURFACE TREATMENT	_____	
SCALE	NTS			
APP	VISHAL	DRG No:- TD 2 B 37 B A2	REV	SHEET
DATE	09.02.2018		0	10F1

Tolerance wherever not specified

Dim	Tolerance Range		
1 - 16	± 0.2	± 0.3	± 0.4
17 - 63	± 0.2	± 0.5	± 0.7
64 - 250	± 0.3	± 0.7	± 1.0
250 - 960	± 0.5	± 0.12	± 1.5

5 4

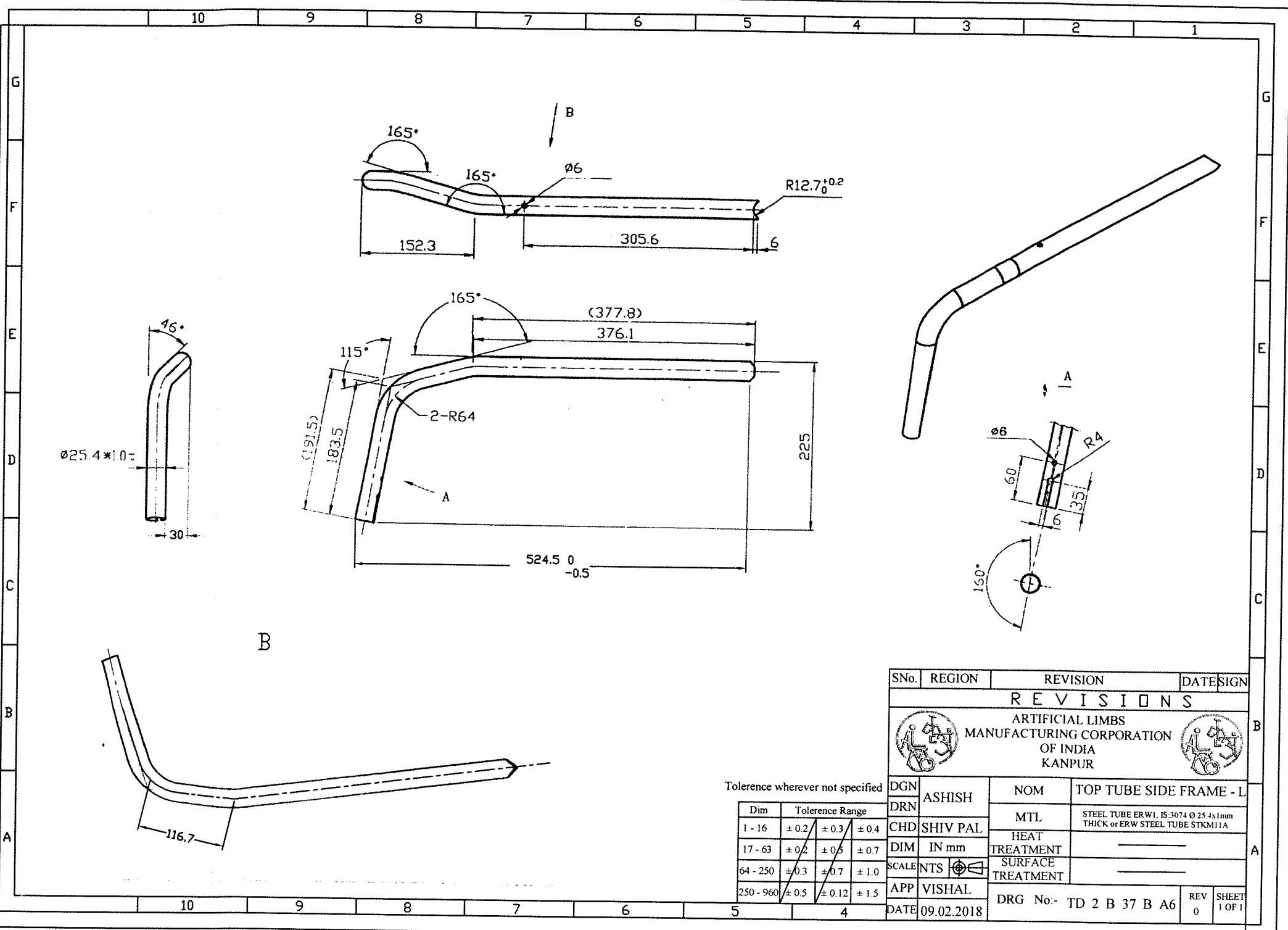

SNo.	REGION	REVISION	DATE	SIGN
REVISIONS				
ARTIFICIAL LIMBS MANUFACTURING CORPORATION OF INDIA KANPUR				
DGN	ASHISH	NOM	TOP TUBE SIDE FRAME - L	
DRN	SHIV PAL	MTL	STEEL TUBE ERW1. IS:3074 \phi 25.4x1mm THICK or ERW STEEL TUBE STKM11A	
CHD	SHIV PAL	HEAT	_____	
DIM	IN mm	TREATMENT	_____	
SCALE	NTS	SURFACE	_____	
APP	VISHAL	TREATMENT	_____	
DATE	09.02.2018	DRG No:- TD 2 B 37 B A6	REV	SHEET
			0	1 OF 1

Tolerance wherever not specified

Dim	Tolerance Range		
1 - 16	± 0.2	± 0.3	± 0.4
17 - 63	± 0.2	± 0.5	± 0.7
64 - 250	± 0.3	± 0.7	± 1.0
250 - 960	± 0.5	± 0.12	± 1.5

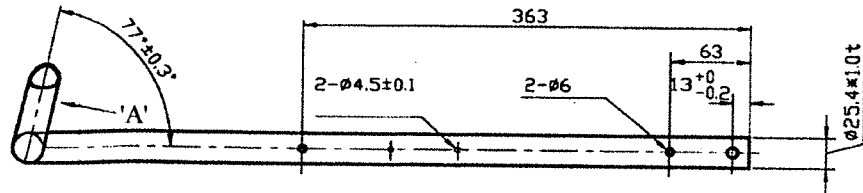

VIEW IN DIRECTION 'A'

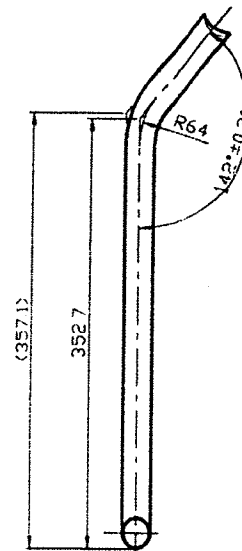
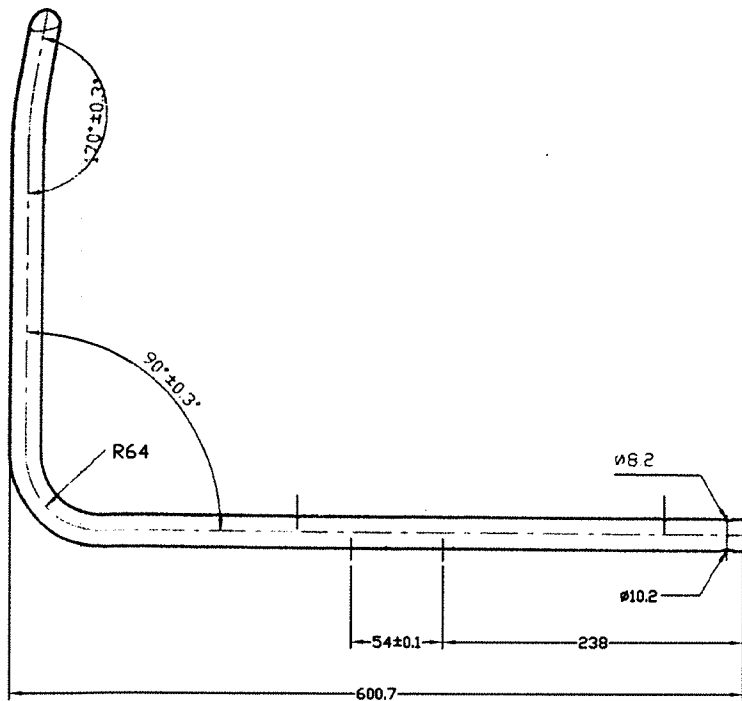
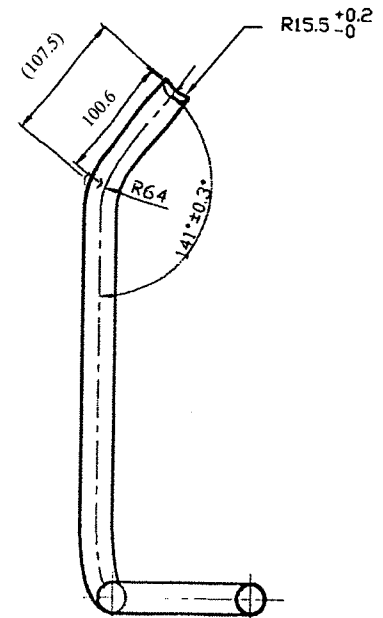

SNo.	REGION	REVISION	DATE	SIGN
------	--------	----------	------	------

REVISIONS



ARTIFICIAL LIMBS
MANUFACTURING CORPORATION
OF INDIA
KANPUR



Tolerance wherever not specified

Dim	Tolerance Range		
1 - 16	± 0.2	± 0.3	± 0.4
17 - 63	± 0.2	± 0.5	± 0.7
64 - 250	± 0.3	± 0.7	± 1.0
250 - 960	± 0.5	± 1.2	± 1.5

DGN	ASHISH	NOM	BACK REST TUBE - R
DRN		MTL	STEEL TUBE ERW1, IS:3074 ∅ 25.4x1mm THICK
CHD	SHIV PAL	HEAT TREATMENT	
DIM	IN mm	SURFACE TREATMENT	
SCALE	NTS		
APP	VISHAL		
DATE	09.02.2018	DRG No:- TD 2 B 37 C A1	REV 0 SHEET 1 OF 1

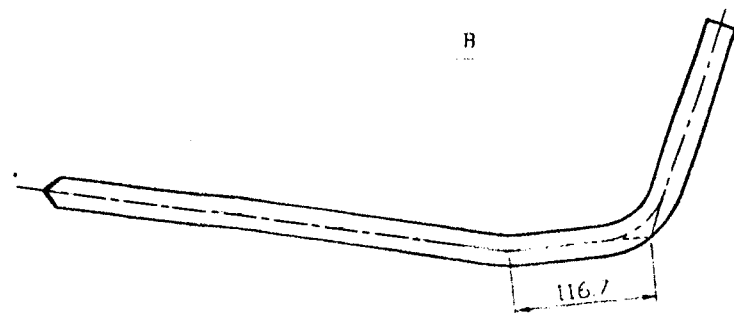
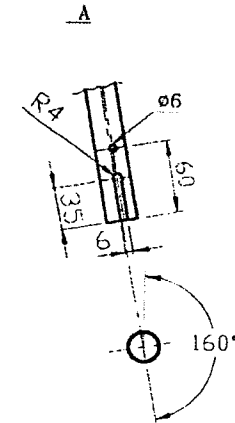
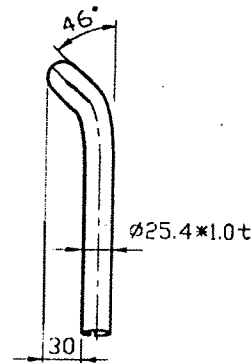
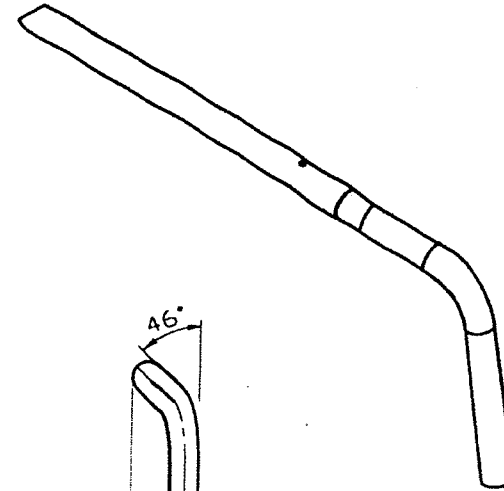
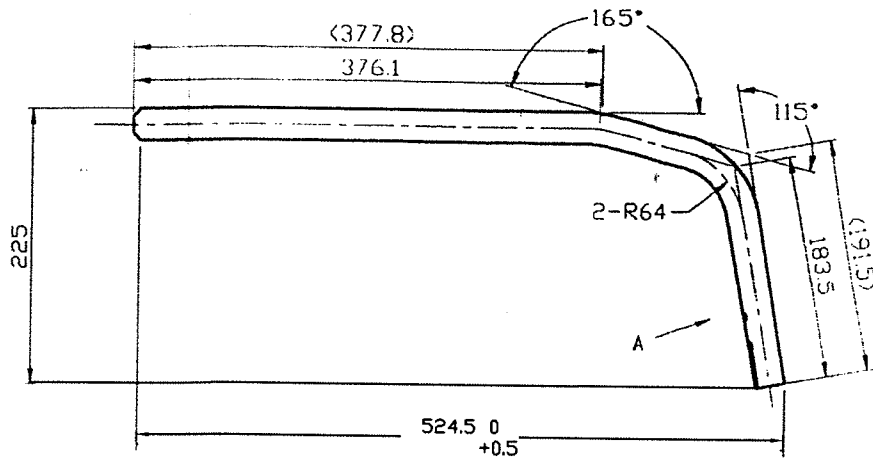
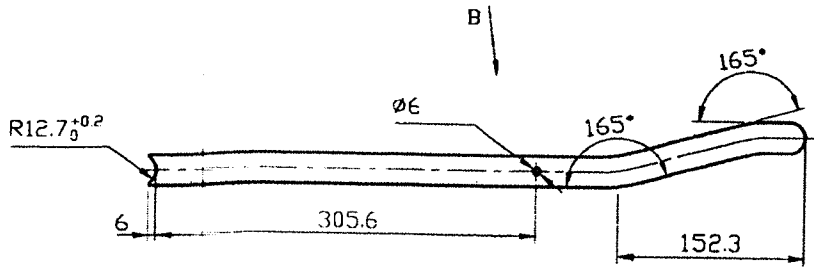

SNo.	REGION	REVISION	DATE	SIGN
------	--------	----------	------	------

REVISIONS

ARTIFICIAL LIMBS
MANUFACTURING CORPORATION
OF INDIA
KANPUR

Tolerance wherever not specified

Dim	Tolerance Range		
1 - 16	± 0.2	± 0.3	± 0.4
17 - 63	± 0.2	± 0.5	± 0.7
64 - 250	± 0.3	± 0.7	± 1.0
250 - 960	± 0.5	± 1.12	± 1.5

DGN	ASHISH	NOM	TOP TUBE SIDE FRAME - R
DRN		MTL	STEEL TUBE ERW1, IS:3074, \phi 25.4x1mm THICK
CHD	SHIV PAL	HEAT	
DIM	IN mm	TREATMENT	
SCALE	NTS	SURFACE	
APP	VISHAL	TREATMENT	
DATE	09.02.2018	DRG No:- TD 2 B 37 C A2	REV 0 SHEET 1 OF 1

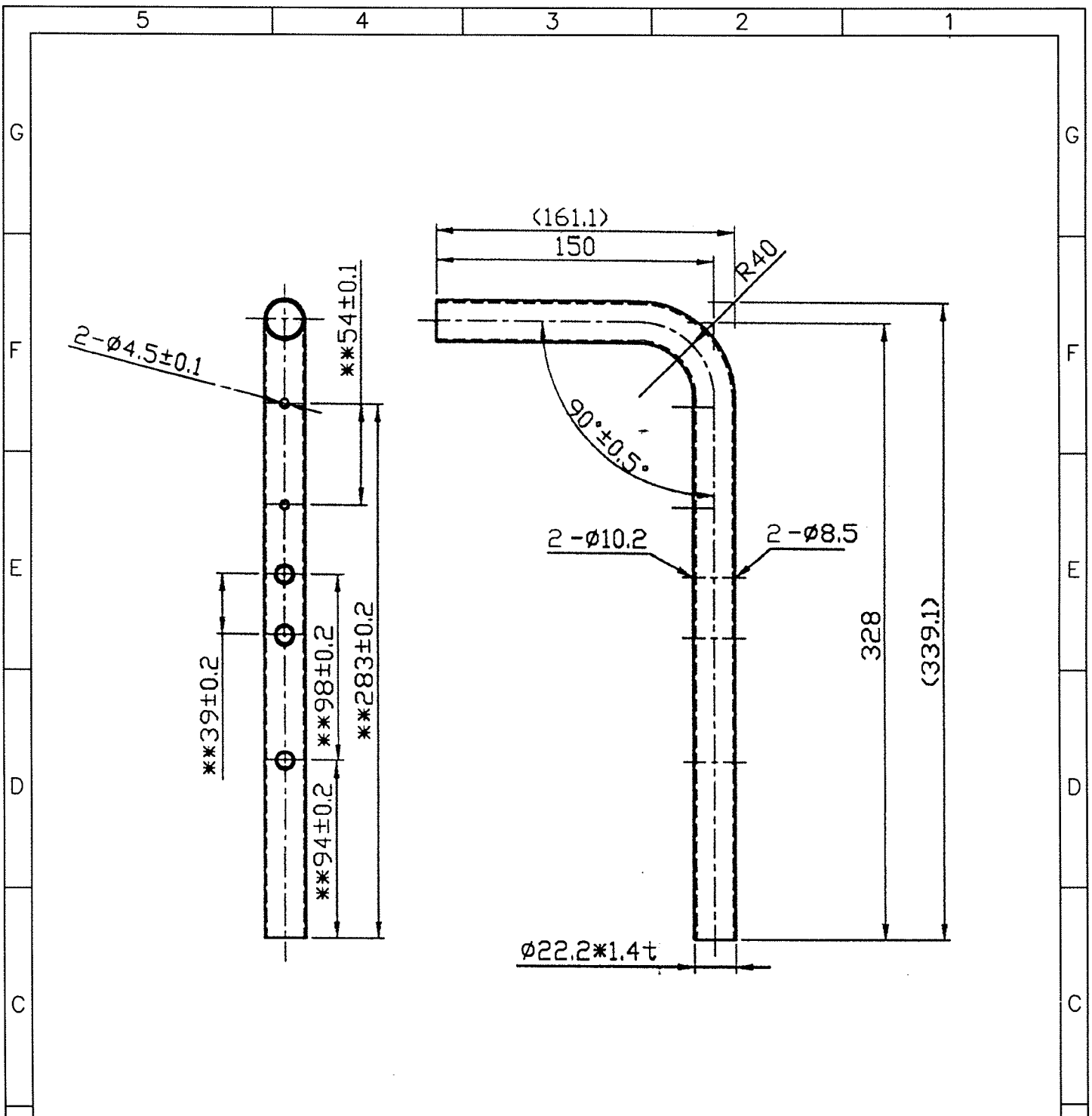

SNo.	REGION	REVISION	DATE	SIGN
------	--------	----------	------	------

R E V I S I O N S

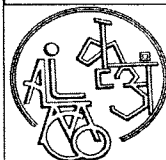

ARTIFICIAL LIMBS
MANUFACTURING CORPORATION
OF INDIA
KANPUR



DGN	ASHISH	NOM	PUSH HANDLE EXTENSION TUBE	
DRN		MTL	STEEL TUBE ERW1, IS:3074, Ø22.2x1.4mm THICK	
CHD	SHIV PAL	HEAT TREATMENT	---	
DIM	IN mm	SURFACE TREATMENT	---	
SCALE	NTS			
APP	VISHAL	DRG No:- TD 2 B 37 E A1	REV	SHEET
DATE	09.02.2018		0	10F1

Tolerance wherever not specified

Dim	Tolerance Range		
1\ 16	± 0.2	± 0.3	± 0.4
17 - 63	± 0.2	± 0.5	± 0.7
64 - 250	± 0.3	± 0.7	± 1.0
250 - 960	± 0.5	± 0.12	± 1.5

5

4

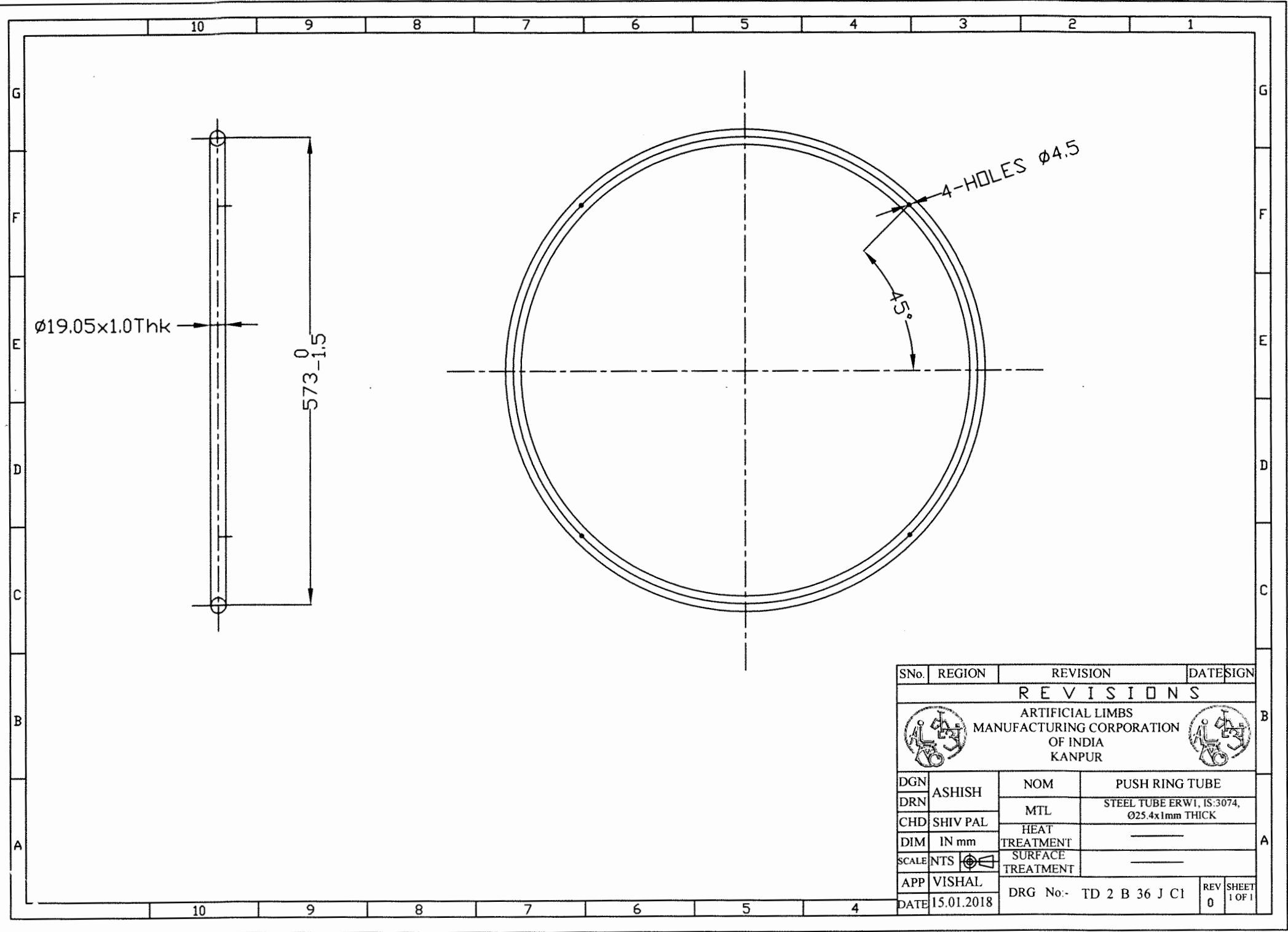



Ø19.05x1.0Thk

573_{-1.5}⁰

4-HOLES Ø4.5

45°

SNo.	REGION	REVISION	DATE	SIGN
REVISIONS				
 ARTIFICIAL LIMBS MANUFACTURING CORPORATION OF INDIA KANPUR 				
DGN	ASHISH	NOM	PUSH RING TUBE	
DRN	SHIV PAL	MTL	STEEL TUBE ERWI, IS:3074, Ø25.4x1mm THICK	
CHD	SHIV PAL	HEAT	_____	
DIM	IN mm	TREATMENT	_____	
SCALE	NTS	SURFACE	_____	
APP	VISHAL	TREATMENT	_____	
DATE	15.01.2018	DRG No:- TD 2 B 36 J C1	REV	SHEET
			0	1 OF 1

ANNEXURE-C

Tender Inviting Authority: ALIMCO, Kanpur

Tender No: PT/OT/09/AW, dated -12.12.2018-, Regarding Supply, Installation & Commissioning of "CNC Tube Bending Machine & Its Software"on Turnkey Basis

PRICE Bid (P-Bid)

Sl. No.	Item Description	Item Code / Make	HSN Code	GSTIN No.	Quantity	Units	Addition / Deduction Values	Currency Conversion against each	Quoted Currency in INR / Other Currency	BASIC RATE In Figures To be entered by the Bidder in Rs. P B	Freight Charges		Packing & Forwarding Charges		Sub Total Amount in Rs. E=B+C+D	GST		Billing Price to Alimco (in Rs.) G=E+F
											(In %)	(In Rs.)	(In %)	(In Rs.)		(In %)	(In Rs.)	
1	Supply of "CNC Tube Bending Machine & Its Software" as per the details enclosed at Annexure-A				1	Set			INR									
2	Installation & Commissioning Charges including Civil, Electrical work on turnkey basis for satisfactory commissioning of the machine/equipment (if any)				1	Job			INR									
3	Supply of any other additional items (other than specified at Annexure-A) which are necessarily required for satisfactory operation of the machine/Equipment/Item				1	Set			INR									
Total (in Rs.) F.O.R ALIMCO,Kanpur									INR									
Total in Words																		

Note:

1. The rates should be separately quoted for supplies to ALIMCO HQ or to its others units, as the case may be ,
2. Giving HSN Code is mandatory and the the bills after placement of order should mention the same HSN Code.
3. Providing correct HSN Code is the responsibility of the vendor and ALIMCO is no way responsible for any subsequent interpretation/order by the Tax authorities.

ADDITIONAL ANNEXURE

Tender Inviting Authority: ALIMCO, Kanpur

Tender No: PT/OT/09/AW, dated -12.12.2018-, Regarding Dismantling, Re-installation & Re-commissioning of "CNC Tube Bending Machine & Its Software" on Turnkey Basis

Sl. No.	Item Description	Item Code / Make	HSN Code	GSTIN No.	Quantity	Units	Addition / Deduction Values	Currency Conversion	Quoted Currency in INR / Other Currency	BASIC RATE In Figures To be entered by the Bidder in Rs. P B	Sub Total Amount in Rs. E	GST F		Billing Price to Alimco (in Rs.) G=E+F
												(In %)	(In Rs.)	
1	Dismantling, Re-installation & Re-commissioning of "CNC Tube Bending Machine & Its Software" on Turnkey Basis as per the details enclosed at Annexure A (refer Note Point No.-7)				1	Set			INR					
Total (in Rs.)									INR					
Total in Words														

Note:

1. This price will not be considered to decide L-1

ADDITIONAL ANNEXURE

Tender Inviting Authority: ALIMCO, Kanpur

Tender No: PT/OT/09/AW, dated -12.12.2018-, Regarding Dismantling, Re-installation & Re-commissioning of "CNC Tube Bending Machine & Its Software" on Turnkey Basis

Sl. No.	Item Description	Item Code / Make	HSN Code	GSTIN No.	Quantity	Units	Addition / Deduction Values	Currency Conversion	Quoted Currency in INR / Other Currency	BASIC RATE In Figures To be entered by the Bidder in Rs. P B	Sub Total Amount in Rs. E	GST F		Billing Price to Alimco (in Rs.) G=E+F
												(In %)	(In Rs.)	
1	Dismantling, Re-installation & Re-commissioning of "CNC Tube Bending Machine & Its Software" on Turnkey Basis as per the details enclosed at Annexure A (refer Note Point No.-7)				1	Set			INR					
Total (in Rs.)									INR					
Total in Words														

Note:

1. This price will not be considered to decide L-1