

BID DOCUMENT

NOTICE INVITING E-TENDER

**Tender Reference No PD/LT/06/AW
Dated: 09.07.2018**

ASSEMBLY OF BICYCLE WHEELS ON JOB WORK BASIS

Tender document may be downloaded from ALIMCO website www.alimco.in (for reference only) and CPPP website <https://eprocure.gov.in/eprocure/app> as per the schedule as given in CRITICAL DATE SHEET as under.

Published Date	20.07.2018 (10:00 Hrs.)
Bid Document Download Start Date	20.07.2018 (15:00 Hrs.)
Bid Submission Start Date	20.07.2018 (15:00 Hrs.)
Bid Submission End Date	10.08.2018 (14:00 Hrs.)
Bid Opening Date	11.08.2018 (15:00 Hrs.)
Date and time of opening of Financial Bids	Will be separately notified for Technically shortlisted/qualified bidders

Interested parties may view and download the tender document containing the detailed terms & conditions from the website <http://eprocure.gov.in/eprocure/app>

**Bids shall be submitted online only at CPPP website: <https://eprocure.gov.in/eprocure/app>.
Tenderer/Contractors are advised to follow the instructions provided in the 'Instructions to the Contractors/Tenderer for the e-submission of the bids online through the Central Public Procurement Portal for e Procurement at <https://eprocure.gov.in/eprocure/app> .**

Bid documents may be scanned with 100 dpi with black and white option which helps in reducing size of the scanned document.

MANUAL BIDS SHALL NOT BE ACCEPTED

except for the original documents/instruments as mentioned in this tender.

Bidders should regularly visit the website to keep themselves updated.

INSTRUCTION FOR ONLINE BID SUBMISSION

The bidders are required to submit soft copies of their bids electronically on the Central Public Procurement (CPP) Portal ie <http://eprocure.gov.in/eprocure/app> , using valid Digital Signature Certificates. The instructions given below are meant to assist the bidders in registering on the CPP Portal, prepare their bids in accordance with the requirements and submitting their bids online on the CPP Portal.

REGISTRATION

- (i) Bidders are required to enroll on the e-Procurement module of the Central Public Procurement Portal (URL:<https://eprocure.gov.in/eprocure/app>) by clicking on the link “Online Bidder Enrollment” option available on the home page. **Enrolment on the CPP Portal is free of charge.**
- (ii) During enrolment/ registration, the bidders should provide the correct/ true information including valid email-id & mobile no. All the correspondence shall be made directly with the contractors/ bidders through email-id provided.
- (iii) As part of the enrolment process, the bidders will be required to choose a unique username and assign a password for their accounts.
- (iv) For e-tendering possession of valid Digital Signature Certificate (Class II or Class III Certificates with signing key usage) is mandatory which can be obtained from SIFY /nCode/eMudra or any Certifying Authority recognized by CCA India on eToken/ SmartCard.
- (v) Upon enrolment on CPP Portal for e-tendering, the bidders shall register their valid Digital Signature Certificate with their profile.
- (vi) Only one valid DSC should be registered by a bidder. Bidders are responsible to ensure that they do not lend their DSCs to others which may lead to misuse and should ensure safety of the same.
- (vii) Bidders can then log into the site through the secured login by entering their userID/ password and the password of the DSC/ eToken.

SEARCHING FOR TENDER DOCUMENTS

- 1) There are various search options built in the CPP Portal to facilitate bidders to search active tenders by several parameters. These parameters could include Tender ID, organization name, location, date, value, etc. There is also an option of advanced search for tenders, wherein the bidders may combine a number of search parameters such as organization name, form of contract, location, date, other keywords, etc., to search for a tender published on the CPP Portal.
- 2) Once the bidders have selected the tenders they are interested in, they may download the required documents / tender schedules. These tenders can be moved to the respective ‘My Tenders’ folder. This would enable the CPP Portal to intimate the bidders through SMS / e-mail in case there is any corrigendum issued to the tender document.
- 3) The bidder should make a note of the unique Tender ID assigned to each tender, in case they want to obtain any clarification / help from the Helpdesk.

PREPARATION OF BIDS:

- (i) For preparation of bid Bidders shall search the tender from published tender list available on site and download the complete tender document and should take into account corrigendum if any published before submitting their bids.
After selecting the tender document same shall be moved to the 'My favourite' folder of bidders account from where bidder can view all the details of the tender document.
- (ii) Bidder shall go through the tender document carefully to understand the documents required to be submitted as part of the bid. Bidders shall note the number of covers in which the bid documents have to be submitted, the number of documents – including the names and content of each of the document that need to be submitted. Any deviations from these may lead to rejection of the bid.
- (iii) Any pre-bid clarifications if required, then same may be obtained online through the tender site, or through the contact details given in the tender document.
- (iv) Bidders should get ready in advance the bid documents in the required format (PDF/xls/rar/dwf/jpg formats) to be submitted as indicated in the tender document/schedule. **Bid documents may be scanned with 100 dpi with black and white option which helps in reducing size of the scanned document.**
- (v) Bidders can update well in advance, the documents such as experience certificates, annual report, PAN, EPF & other details etc., under "My Space/ Other Important Document" option, which can be submitted as per tender requirements. This will facilitate the bid submission process faster by reducing upload time of bids.

SUBMISSION OF BIDS:

- (i) Bidder should prepare the EMD as per the instructions specified in the NIT/ tender document. The details of the DD/BC/BG/ others physically sent, should tally with the details available in the scanned copy and the data entered during bid submission time. Otherwise the uploaded bid will be rejected.
- (ii) While submitting the bids online, the bidder shall read the terms & conditions (of CPP portal) and accepts the same in order to proceed further to submit their bid.
- (iii) Bidders shall select the payment option as offline to pay the Tender Fee/ EMD and enter details of the DD/BC/BG/others.
- (iv) Bidders shall note that the very act of using DSC for downloading the tender document and uploading their offers is deemed to be a confirmation that they have read all sections and pages of the tender document without any exception and have understood the complete tender document and are clear about the requirements of the tender document.
- (v) Bid documents may be scanned with 100 dpi with black and white option which helps in reducing size of the scanned document. For the file size of less than 1 MB, the transaction uploading time will be very fast.
- (vi) **If price quotes are required in XLS format, utmost care shall be taken for uploading Schedule of quantities & Prices and any change/ modification of the price schedule shall render it unfit for bidding.**
Bidders shall download the Schedule of Quantities & Prices i.e. Schedule-D, in XLS format and save it without changing the name of the file. Bidder shall quote their rate in figures in the appropriate cells, thereafter save and upload the file in financial bid cover (Price bid) only.
If the template of Schedule of Quantities & Prices file is found to be modified/corrupted in the eventuality by the bidder, the bid will be rejected.
The bidders are cautioned that uploading of financial bid elsewhere i.e. other than in cover 2 will result in rejection of the tender.

- (vii) Bidders shall submit their bids through online e-tendering system to the Tender Inviting Authority (TIA) well before the bid submission end date & time (as per Server System Clock). **The TIA will not be held responsible for any sort of delay or the difficulties faced during the submission of bids online by the bidders at the eleventh hour.**
- (viii) After the bid submission (i.e. after Clicking “Freeze Bid Submission” in the portal), the bidders shall **take print out of system generated acknowledgement** number, and keep it as a record of evidence for online submission of bid, which will also act as an entry pass to participate in the bid opening.
- (ix) Bidders should follow the server time being displayed on bidder’s dashboard at the top of the tender site, which shall be considered valid for all actions of requesting, bid submission, bid opening etc., in the e-tender system.
- (x) All the documents being submitted by the bidders would be encrypted using PKI (Public Key Infrastructure) encryption techniques to ensure the secrecy of the data. The data entered cannot be viewed by unauthorized persons until the time of bid opening. The confidentiality of the bids is maintained using the secured Socket Layer 128 bit encryption technology.

ASSISTANCE TO BIDDERS:

- (i) Any queries relating to the tender document and the terms and conditions contained therein should be addressed to the Tender Inviting Authority for a tender or the relevant contract person indicated in the tender. The contact number for the helpdesk is 011-29533591, 29573328 between 10:30 hrs to 17:00 hrs.
- (ii) Any queries relating to the process of online bid submission or queries relating to CPP Portal in general may be directed to the 24X7 CPP Portal Helpdesk. The 24 x 7 Help Desk Number 0120-4200462, 0120-4001002 and +91-8826246593. The helpdesk email id is **support-eproc@nic.in**

INSTRUCTION FOR e-PROCUREMENT

1. Preparation and Submission of Bids

- a. The detailed tender documents may be downloaded from <http://eprocure.gov.in/eprocure/app> till the last date of submission of tender. The Tender may be submitted online through CPP Portal <http://eprocure.gov.in/eprocure/app>
- b. The bidder should submit the bid online in two parts viz. Technical Bid and Commercial Bid. Technical Bid should be upload online in cover 1 and Commercial Bid in “.Xls” should be upload online in cover-2

Submission of the Bid:

All interested eligible bidders are requested to submit their bids online on CPP Portal: <http://eprocure.gov.in/eprocure/app> as per the criteria given in this document:

- a. Technical Bid should be upload online in cover-1.
- b. Commercial Bid should be upload online in cover-2

Both Technical and Commercial Bid covers should be placed online on the CPP Portal (<http://eprocure.gov.in/eprocure/app>).

(A) Technical Bid:

Signed and Scanned copies of the Technical bid documents as under must be submitted online on CPP Portal: <http://eprocure.gov.in/eprocure/app> .

A list of Documents to be scanned and uploaded (Under Cover-1) within the period of bid submission:-

- a) Copy of PF Registration
- b) Copy of ESI Registration
- c) Copy of Tender Acceptance letter
- d) Copy of IT Return for Assessment Year 2017-18 or 2018-19.
- e) Copy of PAN Card
- f) Copy of Labour Contract License or declaration that same may be produced within 30 days of award of the contract.
- g) Copy of certificate Goods & Service Tax (GST)
- h) Undertaking as per Annexure ‘A’ by the tenderer. (On Rs. 100/- Non Judicial Stamp Paper)
- i) Performance reports from the clients served over the past three years/copy of job work order for the past three years.

(All these documents / details / conformation should necessarily be submitted specifically & in the same order.)

(B) Financial Bid

Part II ('P'BID): shall consist of complete price details as under: -

- (a) Rates are required to be quoted in Annexure 'C'. **Service Charges per piece basis to be quoted which should be firm and valid throughout the period of contract for one year and the same will be basis of deciding L-1 Tenderer.** The contract may be extended for a further period six months or one year with mutual consent. The service charges shall not be revised during the contract period/completion of ordered quantity.
- (b) Service Charges Quoted by the firm should be fixed for functional quantity or one year from the date of release job work order whichever is early.
- (c) The rates should be quoted giving details as per Annexure 'C'.
- (d) Minimum Wages (Central) payable to workmen employed for Area 'A' shall be revised on revision by the Ministry of Labour & Employment, Govt. of India, New Delhi.
- (e) All the statutory liabilities are to be paid by the tenderer.
- (f) Goods & Services Tax (GST) will be payable as per Govt. Guidelines being statutory levy after submission of proof by tenderers.

Price bids of only those tenderers, who are assessed as technically qualified by the Corporation shall be opened & only Such parties shall be communicated regarding date & time of Price Bid opening requesting them to attend the Tender opening, if interested.

2.0 ELIGIBILITY OF TENDERER:

Tenderers must produce Labour Contract License for the work earlier undertaken by them.

3.0 OPENING OF TENDER:

All the tenderers must submit their offer online on e-procurement portal of corporation by 14.00 hrs. on or before **10.08.2018** and will be opened online on **11.08.2018** at 15.00 hrs. in the presence of representatives of tenderers who may like to be present. If the due date happens to be a holiday the same stands extended to the date of next working day with time remaining the same. However, the Corporation has the right to alter the date & time of Tender closing & opening. The same shall be notified only on the website of E-tender & Corporation.

4.0 TERMS OF PAYMENT:

- 4.1 75% payment against the bill submitted and verified will normally be released by ALIMCO on monthly basis on receipt of monthly bills submitted by the successful tenderer for completed and duly accepted work by our QC after verification. Further balance 25% payment shall be claimed latest within one month from the end of the respective quarter of a year (in line with clause 4.3).
- 4.2 The Contractor shall in no case pay its employees less than the minimum mandatory rates of wages as applicable in the Govt. of India. The Contractor has to deposit the wages of its employees in their respective bank account, a record of that should be kept in a register which may be examined by the Corporation at any time. The Contractor shall ensure that payment to his employees is made through Cheque/bank transfer.
- 4.3 Payment terms is linked to Minimum Wages statutory dues and GST Input credit in the following manner:-
 - (a) 75% of Rate excluding GST on verification of quantity and advise by PD Deptt.

- (b) 25% of Rate excluding GST on submission of challans evidencing payment of statutory dues duly certified by PD Deptt.
- (c) GST amount payment on availment of Input Credit.
- 4.4 The balance 25% payment will be release on submission of proof of payment of contribution towards PF, ESI, Copy of Form 12 & Goods & Service Tax, Input/Credit avail and after complying with labour laws. The PF, ESI, Copy of Form 12 should be certified by the user dept. evidencing the actual no. of labourer employed in the job work.
- 4.5 Successful tenderer shall make payment to the persons employed as per minimum wages act 1948 of Govt. of India for Area 'A', any increase in the minimum wages by the Govt. authorities during the pendency of contract it is to be immediately implemented by the contractor and same shall be revised by the Corporation on submission of proof. The payment to the person employed shall be made latest by 7th day of the subsequent month.
- 4.6 After making of payment to the person employed as above and depositing PF, ESI and Goods & Service Tax (GST) within the stipulated period, Certified copies of challans for payment of PF, ESI & GST contribution in respect of his personnel is required to be enclosed by the successful tenderer along with its bills to enable ALIMCO to process the same for Contractor's payment after other applicable statutory deductions. Original challans need to be produced for verification as and when so asked for. Payment shall be made within 15 days from the date of receipt duly verified bills for satisfactory completion of work by the concerned executives along with requisite documents. Conditions mentioned above are required to be complied with and are directed to enclose the pay bill relating to the workmen engaged by the contractor duly covering the details of the workmen employed like – name of the workmen, section in which he is posted, work he is doing, number of actual days attended, minimum daily wage rate applicable, actual wages payable, deductions towards PF & ESI, net payment paid to the workmen, signature of the individual's workmen. Copy of Form 12 to be submitted alongwith proof of deposit of PF & ESI within 15 days, duly certified by user department also.
- 4.7 Productivity is a major issue as the Corporation is ensuring payment of Minimum wages to manpower engaged. The tenderer should ensure productivity of the manpower based on "Manpower per 100 units" mentioned in Annexure 'C'. In case the productivity of manpower is below 100% in the month, a penalty will be imposed on tenderer on short fall quantity at the end of month which will be 120% of piece rate per item.

5.0 VALIDITY OF OFFER/QUOTATION:

- 5.1 The offer/quotation submitted against this Tender shall be valid upto 90 days from the date of opening tender.
- 5.2 The Tenderers shall be bound by terms of this tender documents, if notification of acceptance of the offer against this tender is issued within the validity period.

6.0 GENERAL TERMS & CONDITIONS OF TENDER:

- 6.1 Details of Scope of works is as per Annexure 'B':-
- 6.2 All Raw materials, components, bought outs, consumables, tools, jigs fixtures and machines shall be provided by ALIMCO. Only labour charges are required to be quoted.
- 6.3 The tentative quantities indicated at Annexure 'B' may be changed upward or downward as per requirement.
- 6.4 The components/bought outs is required to be collected from previous work station/stores. Requisite Bins and Trolleys shall be provided by ALIMCO for material handling/movement of materials. All completed assemblies must be delivered/shifted to the place within corporation indicated by us time to time.

- 6.5 The work may be executed in between 0900 hrs. to 1730 hrs. and as when required by the Corporation.
- 6.6 Timely and trouble free work completion need to be ensured.
- 6.7 Tenderers are requested to visit ALIMCO, Kanpur between 1400 to 1600 hours on any working day (Monday to Friday) to assess the nature and volume of job so as to correctly estimate the rate to be quoted against this tender.
- 6.8 All works are to be carried out within the premises of ALIMCO, Kanpur.
- 6.9 The Job Order shall be placed on single tenderer for complete job work at Sl.No.1 to 2 of Annexure 'B' on the basis of lowest consolidated value basis (L-1).** In case of split upto 3 parties, 60% of the quantity may be placed on L-1 and 20% each on L-2 & L-3 provided they agree to match the rate with L-1 and in case of split upto 02 parties 60% of the quantity may be placed on L-1 and 40% on L-2 provided L-2 agree to match rates with L-1.
- 6.10 Labour Contract Licence under Contract Labour (Regulation & Abolition) Act, 1970 is required to be obtained by the successful tenderer within 30 days of award of the Contract and a copy of the same submitted to us.
- 6.11 The terms of this tender including the terms of payment will not be relaxed.
- 6.12 Any offer submitted against this tender in deviation from the terms of this tender will stand rejected.
- 6.13 An undertaking for unconditional acceptance of all the terms & conditions mentioned in this tender documents must accompany the Bid as per **Annexure 'A'**, otherwise the offer shall stand rejected.
- 6.14 The success tenderer shall not sub - contract the work awarded against the Tender.
- 6.15 The tenderer will be the sole employer of personnel deployed for execution of JWO. The Corporation shall have no casual or remote connection with the employees of Tenderer. To supervise, manage and control such persons would be the sole responsibility of the Tenderer.
- 6.16 The Successful tenderer shall be solely responsible for the safety, security, insurance etc. of the personnel deployed by it. ALIMCO shall not be at all responsible for any loss or claim whatsoever for the personnel deployed, by successful tenderer, or their heirs.
- 6.17 The job work carried out by the tenderer shall be inspected by the Corporation's inspecting agency and the decision of the Inspecting Officer shall be final and binding.
- 6.18 All entries in the offer shall be either typed or neatly hand written. Tenders having over writings/fluid application/cutting etc. without proper authentication will be rejected.
- 6.19 Conditional Offer / Quotation shall not be acceptable.**
- 6.20 The Job Work Order can be short closed by giving 30 days clear notice by ALIMCO without assigning any reason.
- 6.21 While scrutinizing the Tenders if a difference is detected between the unit price and the total price the former will prevail. In case of discrepancy between the figures and words, the latter would prevail. The arithmetical errors mentioned above shall not be the cause of rejection of a Tender.
- 6.22 All quotations, contracts and orders are subject to the jurisdiction of the appropriate local court at Kanpur, **District: Kanpur Nagar, UP (India) only.**
- 6.23 The Corporation has right to place Order for an additional quantity equal to 100% of the original Order, if finalized on you, at same rates, terms & conditions within a period of six months from the date of last supply or during the currency of the Order.
- 7.0 RIGHT OF ACCPETANCE:**
ALIMCO reserves the right to reject any or all the tenders in part or full without assigning any reason thereof. In order to ensure that there are no freak quotes. The Corporation reserves the right to do its internal working and reject such quotes. The Corporation also reserves the right to, reduce or increase the quantity and split the order as per clause 1.9 without assigning any reason thereof.

8.0 **Force Majeure**:- In the event that the Supplier or any of its subcontractors, or the purchaser is delayed in performing any of its respective obligations under the Contract, and such delay is caused by Force Majeure, including but not limited to war, civil insurrection, fires, floods, epidemics, earthquakes, quarantine restrictions and freight embargoes, such delay may be excused and the period of such delay may be added to the time and performance of the obligation delayed.

9.0 **ARBITRATION:**

9.1 If any dispute/question or controversy arises in respect of or arising out of the assignment / Job Work Contract, the matter in dispute shall be referred to the arbitration of the Chairman & Managing Director of ALIMCO or its nominee and the decision of the Chairman and Managing Director or nominee shall be final and binding on both the parties.

9.2 The provision of the **ARBITRATION & CONCILATION ACT 1996** as amended from time to time shall apply to such arbitration proceedings.

9.3 Arbitration proceedings shall be held at Kanpur only and the Kanpur City Court will have the Jurisdiction in the matter.

Encl.: Annexure – ‘A’, ‘B’, ‘C’, ‘C-1’, ‘D’ & ‘E-1’ TO ‘E-4’.

Authorized Signatory
For Artificial Limbs Manufacturing Corporation of India
G T Road, Kanpur

(On Rs. 100.00 Non Judicial Stamp Paper)

Annexure 'A'

UNDERTAKING BY THE TENDERER

I/We agree to abide by all terms & conditions of E-Tender Notice No. _____ dated _____ of ALIMCO and undertake to ensure compliance all statutory obligations including payment of Govt. levies.

I/We shall also fully comply with provisions of Contract Labour Act, ESI Act, Employee Provident Fund, GST & Misc. Provisions Act and other Labour Law as applicable during the tenure of Job Work Contract and own all liabilities on this account including accidental, if any, in case the Job Work Contract is finalized in our favour.

I/ We shall recruit control, supervise and make payment of wages to persons deployed by me/ us at ALIMCO for execution of the tender / JWO.

I/We will not make any claim, other than the amount as per rates quoted by us at Annexure "C" as the rates quoted by us are inclusive of all liabilities under various Labour Laws.

I/We assure the management of ALIMCO that my/ our employees will never claim for employment with ALIMCO or demand any other facility including compensation, from ALIMCO.

In case, any liability financial or otherwise comes upon ALIMCO on account of non-compliance of statutory provisions on my/ our part or due to any act or deed on my / our part, I/ We undertake to indemnify ALIMCO for the same.

In case of lesser payment of PF, ESI and GST as per Challan, we agree to reduce the Billing amount with the difference between amount chargeable as per JWO and the amount actually paid.

Signature _____
Name _____

Seal

Date

ASSEMBLY OF BICYCLE WHEELS ON JOB WORK BASIS

1.0 SCOPE OF WORK

- 1.1 The work involves as per details given in Table-1 as per respective drawings
- 1.2 All material/components/bought out and required production tools, working space, light and drinking water etc. shall be provided by the Corporation. However, required hand tools for fabrication work will have to be arranged by tenderer.
- 1.3 The work needs to be done generally in between 09.00 hrs. to 17.30 hrs. on working days and as when required by the Corporation.
- 1.4 Simultaneous, trouble free & timely progress/completion of work needs to be ensured.
- 1.5 Tenderers are requested to visit ALIMCO, Kanpur between 14.00 hrs. to 16.00 hrs. on any working day (Monday to Friday) to assess the nature and volume of job, all jobs are to be carried out within the premises of ALIMCO, Kanpur under the supervision of Corporation Representative / as per instructions.
- 1.6 Issue of material and store crediting of acceptable items will have to be arranged by tenderer collection of components & shifting of sub-assemblies from / to respective stores will have to be done by the tenderer at **Sl.No.1 to 2.**
- 1.8 **The Job Order shall be placed on single tenderer for complete job work at Sl.No.1 to 2 on the basis of lowest consolidated value basis (L-1).** In case of split upto 3 parties, 60% of the quantity may be placed on L-1 and 20% each on L-2 & L-3 provided they agree to match the rate with L-1 and in case of split upto 02 parties 60% of the quantity may be placed on L-1 and 40% on L-2 provided L-2 agree to match rates with L-1.

Table-1

Sl.No.	Code No	Description of work	Unit	Qty.
1	LD28/LJ57	Front wheel Assy Size 28"x 1½ , 40 Holes.Assembly of Rim, Spoke, Nipple, Washer and Hub and Trueing of wheel	Nos.	17500
2	LD29/LJ58	Rear wheel Assy Size 28"x 1½, 40 Hole.Assembly of Rim, Spoke, Nipple, Washer and Hub and Trueing of wheel	Nos.	35000

Terms & Conditions of P-Bid for Annexure 'C'

1. The Contractor shall be reimbursed minimum wages for the above manpower along with statutory dues like PF, ESI and other as applicable. Only service charges has to be quoted by contractor which will be fixed per piece for the tenure of the contract.
2. The liability of the contractor is to make payment of minimum wages for the workers required under this contract through Form XII. He shall also pay the statutory dues.
3. The Service Charges are to be quoted in unit price which shall remain fix for the tenure of the contract.
4. Any change in GST will be admitted during pendency of the contract.
5. In case Government decides to levy GST on RCM basis, the corporation shall make the payment being statutory due and the same is not required to be billed.
6. The Job Order shall be placed on single tenderer for complete job work at **Sl.No.1 to 2** on the basis of lowest consolidated value basis (L-1). In case of split upto 3 parties, 60% of the quantity may be placed on L-1 and 20% each on L-2 & L-3 provided they agree to match the rate with L-1 and in case of split upto 02 parties 60% of the quantity may be placed on L-1 and 40% on L-2 provided L-2 agree to match rates with L-1.
7. The successful tenderer on receipt of the Job Work Order, raise bill as follows:
Reimbursement of Basic Minimum Wages _____
+13.16% PF on Basic Minimum Wages _____
+4.75% ESI on Basis Wages _____
+Service Charges (As quoted) _____
Per piece
Subtotal (A) _____
+GST on Subtotal (A) _____
Total _____

TENDER ACCEPTANCE LETTER
(To be given on Company Letter Head)

Date:

To,

Sub: Acceptance of Terms & Conditions of Tender.

Tender Reference No: _____

Name of Tender / Work: -

Dear Sir,

1. I / We have downloaded / obtained the tender document(s) for the above mentioned 'Tender/Work' from the web site(s) namely:

as per your advertisement, given in the above mentioned website(s).

2. I / We hereby certify that I / we have read the entire terms and conditions of the tender documents from Page No. _____ to _____ (including all documents like annexure(s), schedule(s), etc .), which form part of the contract agreement and I / we shall abide hereby by the terms / conditions / clauses contained therein.

3. The corrigendum(s) issued from time to time by your department/ organisation too have also been taken into consideration, while submitting this acceptance letter.

4. I / We hereby unconditionally accept the tender conditions of above mentioned tender document(s) / corrigendum(s) in its totality / entirety.

5. I / We do hereby declare that our Firm has not been blacklisted/ debarred/ terminated/ banned by any Govt. Department/Public sector undertaking.

6. I / We certify that all information furnished by our Firm is true & correct and in the event that the information is found to be incorrect/untrue or found violated, then your department/ organisation shall without giving any notice or reason therefore or summarily reject the bid or terminate the contract, without prejudice to any other rights or remedy including the forfeiture of the full said earnest money deposit absolutely.

Yours Faithfully,
(Signature of the Bidder, with Official Seal)

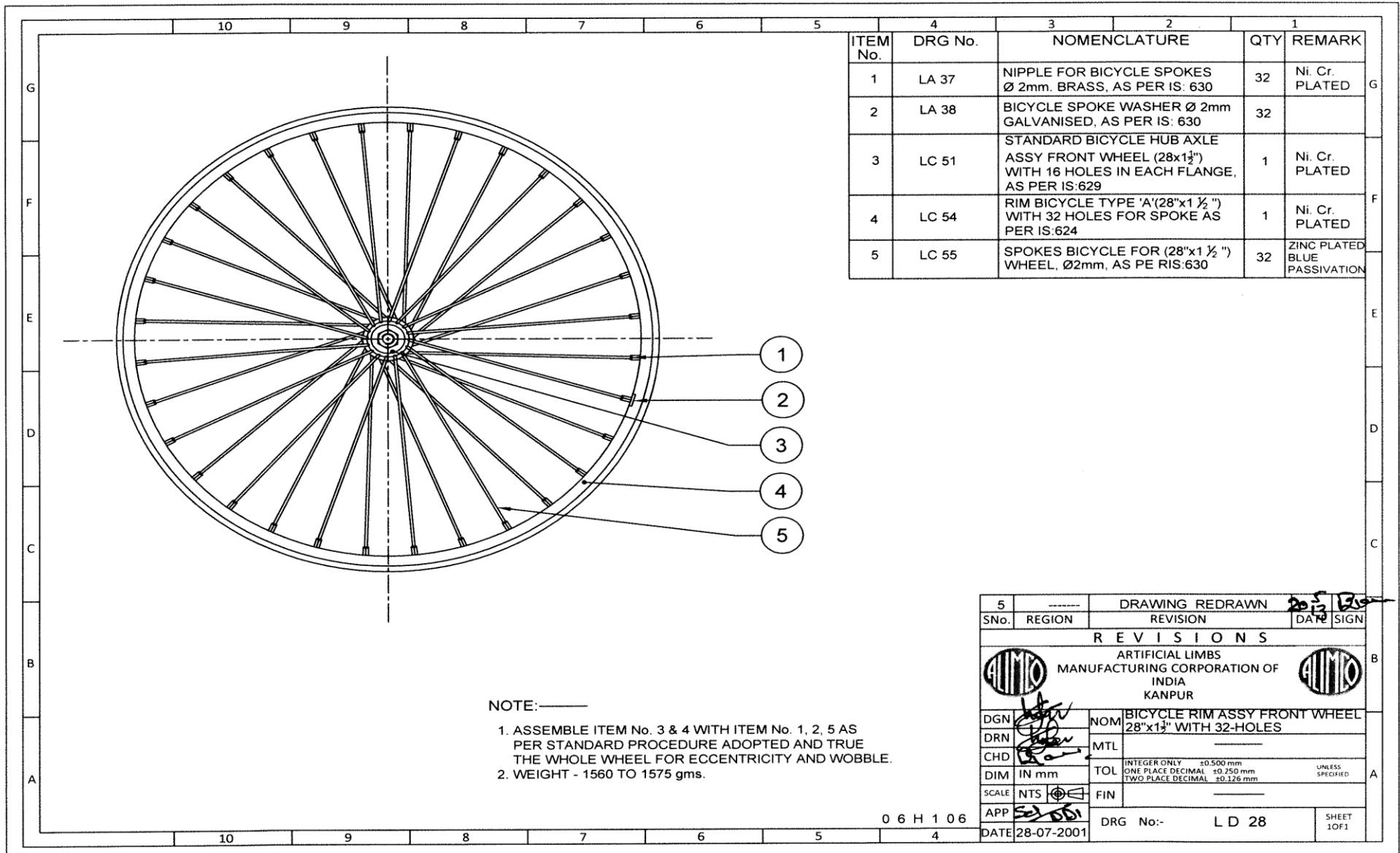

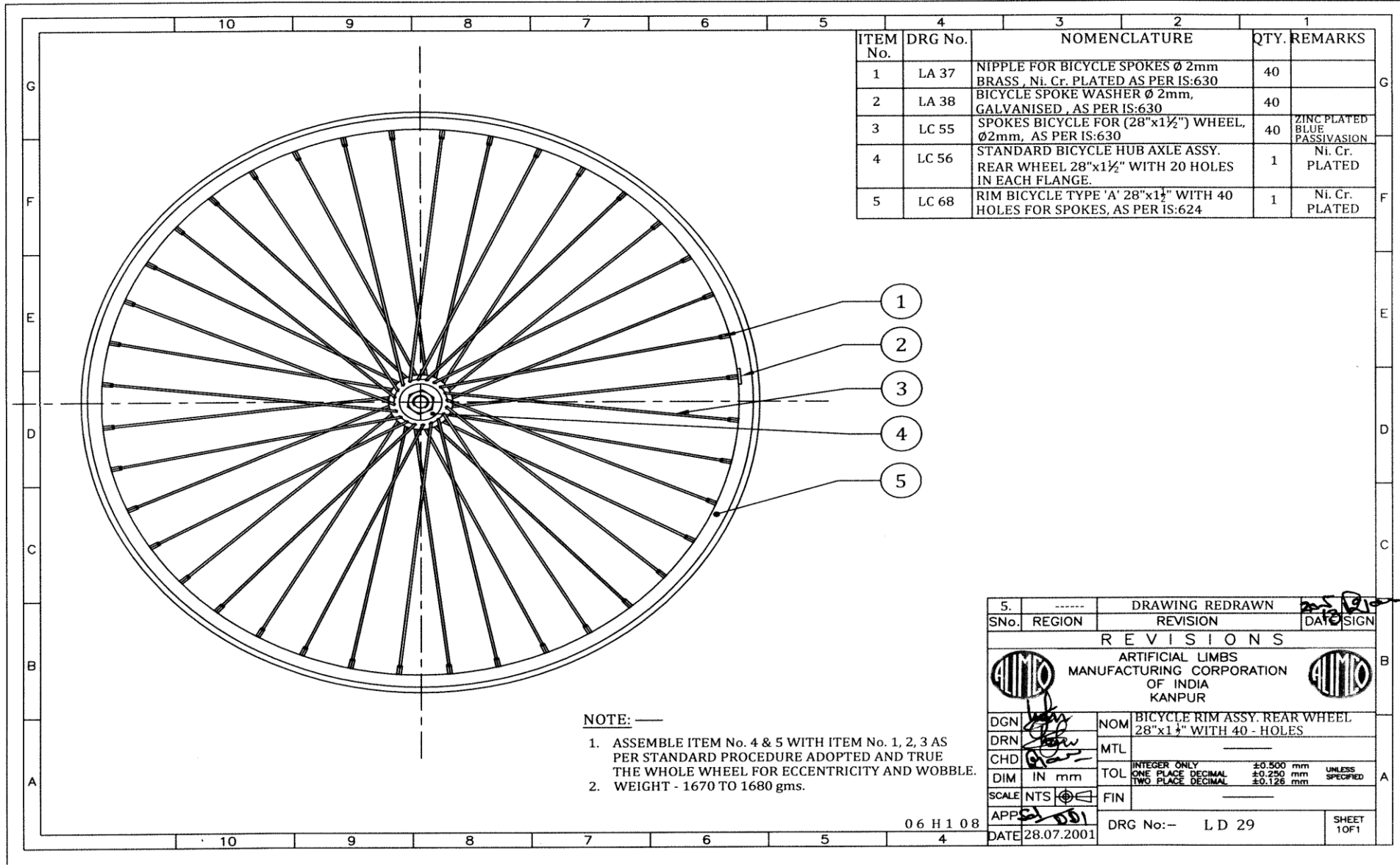

ITEM No.	DRG No.	NOMENCLATURE	QTY.	REMARKS
1	LA 37	NIPPLE FOR BICYCLE SPOKES Ø 2mm BRASS, Ni. Cr. PLATED AS PER IS:630	40	
2	LA 38	BICYCLE SPOKE WASHER Ø 2mm, GALVANISED, AS PER IS:630	40	
3	LC 55	SPOKES BICYCLE FOR (28"x1½") WHEEL, Ø2mm, AS PER IS:630	40	ZINC PLATED BLUE PASSIVATION
4	LC 56	STANDARD BICYCLE HUB AXLE ASSY. REAR WHEEL 28"x1½" WITH 20 HOLES IN EACH FLANGE.	1	Ni. Cr. PLATED
5	LC 68	RIM BICYCLE TYPE 'A' 28"x1½" WITH 40 HOLES FOR SPOKES, AS PER IS:624	1	Ni. Cr. PLATED

NOTE: —

1. ASSEMBLE ITEM No. 4 & 5 WITH ITEM No. 1, 2, 3 AS PER STANDARD PROCEDURE ADOPTED AND TRUE THE WHOLE WHEEL FOR ECCENTRICITY AND WOBBLE.
2. WEIGHT - 1670 TO 1680 gms.

5.	-----	DRAWING REDRAWN	<i>[Signature]</i>
SNNo.	REGION	REVISION	DATE SIGN
REVISIONS			
ARTIFICIAL LIMBS MANUFACTURING CORPORATION OF INDIA KANPUR			
DGN	<i>[Signature]</i>	NOM	BICYCLE RIM ASSY. REAR WHEEL
DRN	<i>[Signature]</i>	MTL	28"x1½" WITH 40 - HOLES
CHD	<i>[Signature]</i>	TOL	INTEGER ONLY ±0.500 mm ONE PLACE DECIMAL ±0.250 mm TWO PLACE DECIMAL ±0.126 mm UNLESS SPECIFIED
DIM	IN mm	FIN	
SCALE	NTS		
APP	<i>[Signature]</i>	DRG No:--	LD 29
DATE	28.07.2001		SHEET 10F1

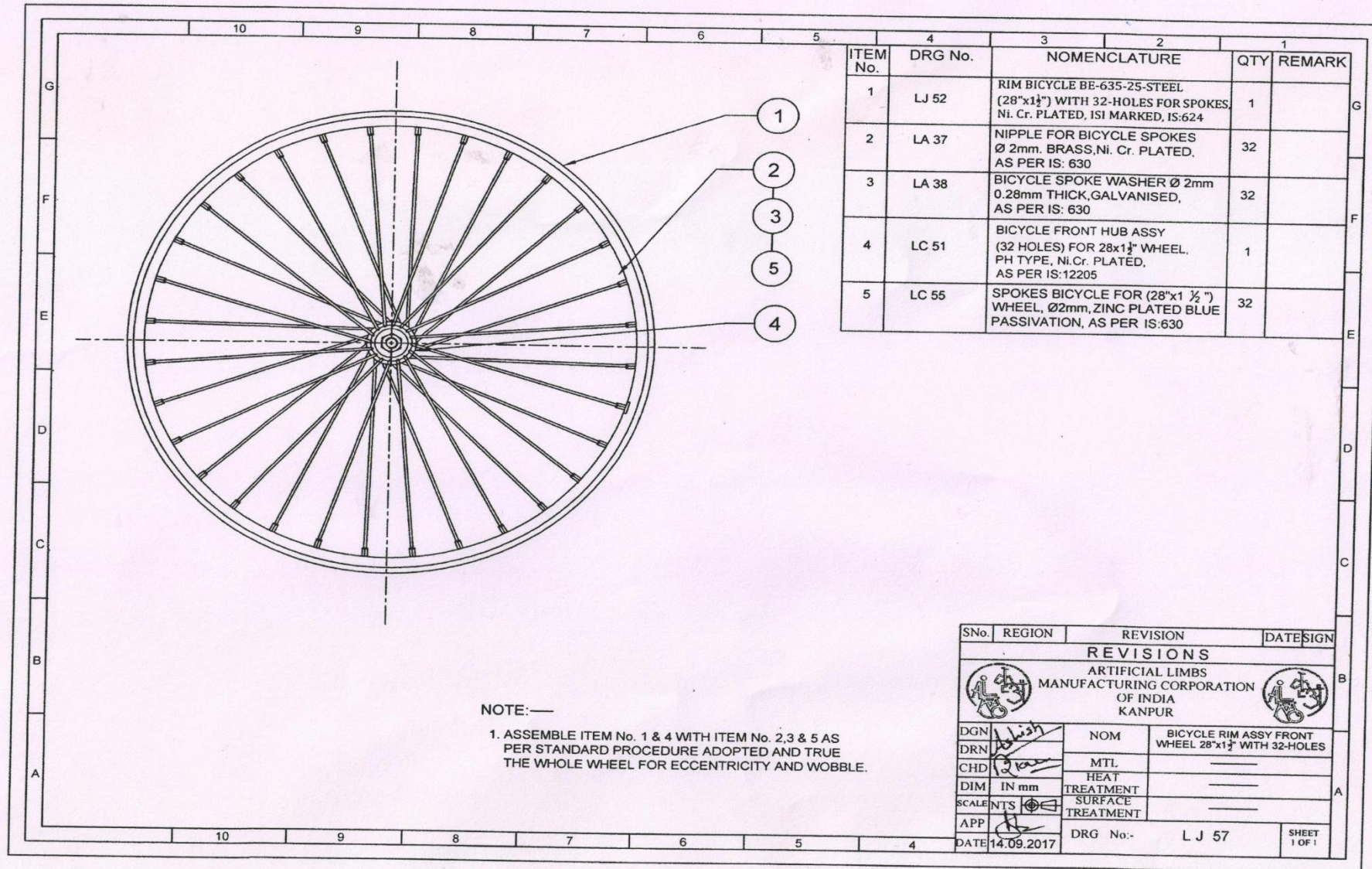

ITEM No.	DRG No.	NOMENCLATURE	QTY	REMARK
1	LJ 52	RIM BICYCLE BE-635-25-STEEL (28"x1½") WITH 32-HOLES FOR SPOKES, Ni. Cr. PLATED, ISI MARKED, IS:624	1	
2	LA 37	NIPPLE FOR BICYCLE SPOKES Ø 2mm. BRASS, Ni. Cr. PLATED, AS PER IS: 630	32	
3	LA 38	BICYCLE SPOKE WASHER Ø 2mm 0.28mm THICK, GALVANISED, AS PER IS: 630	32	
4	LC 51	BICYCLE FRONT HUB ASSY (32 HOLES) FOR 28x1½" WHEEL, PH TYPE, Ni.Cr. PLATED, AS PER IS:12205	1	
5	LC 55	SPOKES BICYCLE FOR (28"x1 ½ ") WHEEL, Ø2mm, ZINC PLATED BLUE PASSIVATION, AS PER IS:630	32	

NOTE:—
1. ASSEMBLE ITEM No. 1 & 4 WITH ITEM No. 2,3 & 5 AS PER STANDARD PROCEDURE ADOPTED AND TRUE THE WHOLE WHEEL FOR ECCENTRICITY AND WOBBLE.

SNo.	REGION	REVISION	DATE	SIGN
REVISIONS				
ARTIFICIAL LIMBS MANUFACTURING CORPORATION OF INDIA KANPUR				
DGN	DRN	NOM	BICYCLE RIM ASSY FRONT WHEEL 28"x1½" WITH 32-HOLES	
CHD		MTL		
DIM	IN mm	HEAT		
SCALE	NTS	TREATMENT		
APP		SURFACE		
DATE	14.09.2017	DRG No.-	L J 57	SHEET 1 OF 1

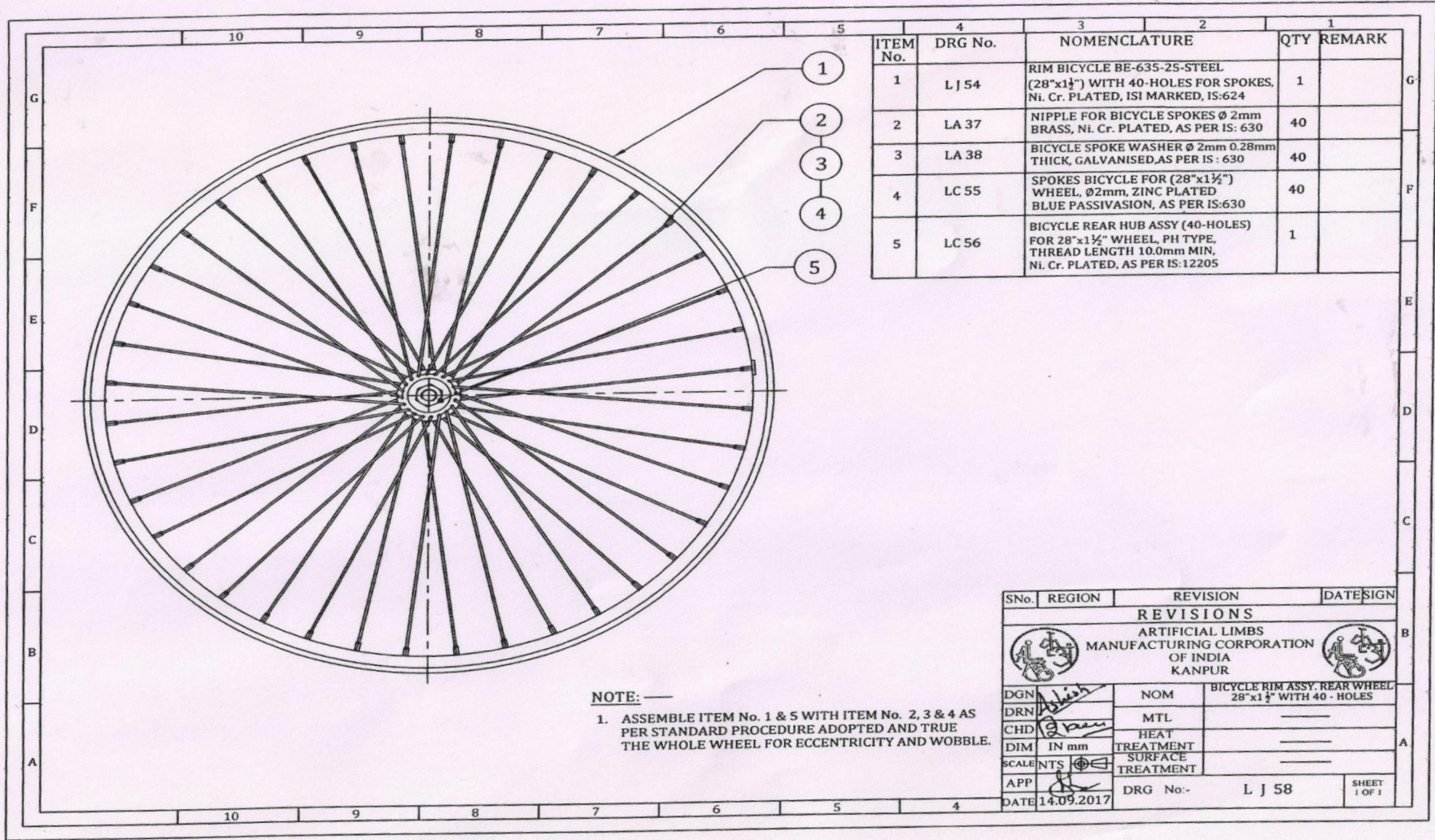

ITEM No.	DRG No.	NOMENCLATURE	QTY	REMARK
1	LJ 54	RIM BICYCLE BE-635-25-STEEL (28"x1 1/2") WITH 40-HOLES FOR SPOKES, Ni. Cr. PLATED, ISI MARKED, IS:624	1	
2	LA 37	NIPPLE FOR BICYCLE SPOKES Ø 2mm BRASS, Ni. Cr. PLATED, AS PER IS: 630	40	
3	LA 38	BICYCLE SPOKE WASHER Ø 2mm 0.28mm THICK, GALVANISED, AS PER IS: 630	40	
4	LC 55	SPOKES BICYCLE FOR (28"x1 1/2") WHEEL, Ø2mm, ZINC PLATED BLUE PASSIVATION, AS PER IS:630	40	
5	LC 56	BICYCLE REAR HUB ASSY (40-HOLES) FOR 28"x1 1/2" WHEEL, PH TYPE, THREAD LENGTH 10.0mm MIN, Ni. Cr. PLATED, AS PER IS:12205	1	

NOTE: —

1. ASSEMBLE ITEM No. 1 & 5 WITH ITEM No. 2, 3 & 4 AS PER STANDARD PROCEDURE ADOPTED AND TRUE THE WHOLE WHEEL FOR ECCENTRICITY AND WOBBLE.

SNo.	REGION	REVISION	DATE	SIGN
REVISIONS				
ARTIFICIAL LIMBS MANUFACTURING CORPORATION OF INDIA KANPUR				
DGN	<i>Abhishek</i>	NOM	BICYCLE RIM ASSY. REAR WHEEL 28"x1 1/2" WITH 40 - HOLES	
DRN		MTL	---	
CHD	<i>Abhishek</i>	HEAT	---	
DIM	IN mm	TREATMENT	---	
SCALE	NTS	SURFACE TREATMENT	---	
APP	<i>Abhishek</i>	DRG No:-	L J 58	SHEET 1 OF 1
DATE	14.09.2017			