



ALIMCO

**Artificial Limbs Manufacturing
Corporation of India
(A GOVERNMENT OF INDIA UNDERTAKING)
G.T. ROAD, KANPUR-U.P.
209217**

TENDER NO. MM/LT/89/AW, DATE- 27.12.2018

BID SUBMISSION END DATE- 17.01.2019

TENDER DOCUMENTS

FOR

“Bicycle Hub, Free Balls & Other Bicycle Items”

Dear Sir,

1. **Online tenders are invited for Item Code No. HK02, HK03, HK05, HK06, HK12, LB52, LB56, LC51, LC04 (Bicycle Hub, Free Balls & Other Bicycle Items) strictly as per ALIMCO Specifications, against Purchase Orders to be placed on the successful Tenderer within specified period as per Purchase Order. Manual bids shall not be accepted.**
2. **Tender documents may be downloaded from ALIMCO website www.alimco.in (for reference only) and CPPP website <https://eprocure.gov.in/eprocure/app>. The tender schedules are mentioned below.**

CRITICAL DATE SHEET

Published Date	27.12.2018 (15:00)
Bid Document Download Start Date	27.12.2018 (15:05)
Bid Submission Start Date	27.12.2018 (15:10)
Bid Submission End Date	17.01.2019 (14:00)
Bid Opening Date	18.01.2019 (15:30)

Bids shall be submitted online only at CPPP website: <https://eprocure.gov.in/eprocure/app>.

Tenderer/Contractors are advised to follow the instructions provided in the 'Instructions to the Contractors/Tenderer for the e-submission of the bids online through the Central Public Procurement Portal for e Procurement at <https://eprocure.gov.in/eprocure/app>.

INSTRUCTION FOR ONLINE BID SUBMISSION

The bidders are required to submit soft copies of their bids electronically on the Central Public Procurement (CPP) Portal i.e. <http://eprocure.gov.in/eprocure/app>, using valid Digital Signature Certificates. The instructions given below are meant to assist the bidders in registering on the CPP Portal, prepare their bids in accordance with the requirements and submitting their bids online on the CPP Portal.

REGISTRATION

- (i) Bidders are required to enroll on the e-Procurement module of the Central Public Procurement Portal by using the "Online Bidder Enrollment" option available on the home page. **Enrolment on the CPP Portal is free of charge.**
- (i) During enrolment/ registration, the bidders should provide the correct/ true information including valid email-id & mobile no. All the correspondence shall be made directly with the contractors/ bidders through email-id provided.
- (ii) As part of the enrolment process, the bidders will be required to choose a unique username and assign a password for their accounts.
- (iii) For e-tendering possession of valid Digital Signature Certificate (Class II or Class III Certificates with signing key usage) is mandatory which can be obtained from SIFY /nCode/eMudra or any Certifying Authority recognized by CCA India on eToken/ Smartcard.
- (iv) Upon enrolment on CPP Portal for e-tendering, the bidders shall register their valid Digital Signature Certificate with their profile.
- (v) Only one valid DSC should be registered by a bidder. Bidders are responsible to ensure that they do not lend their DSCs to others which may lead to misuse and should ensure safety of the same.
- (vi) Bidders can than log into the site through the secured login by entering their user ID/ password and the password of the DSC/ eToken.

SEARCHING FOR TENDER DOCUMENTS

- (vii) There are various search options built in the CPP Portal to facilitate bidders to search active tenders by several parameters. These parameters could include Tender ID, organization name, location, date, value, etc. There is also an option of advanced search for tenders, wherein the bidders may combine a number of search parameters such as organization name, form of contract, location, date, other keywords, etc., to search for a tender published on the CPP Portal.
- (viii) Once the bidders have selected the tenders they are interested in, they may download the required documents / tender schedules. These tenders can be moved to the respective 'My Tenders' folder. This would enable the CPP Portal to intimate the bidders through SMS / e-mail in case there is any corrigendum issued to the tender document.
- (ix) The bidder should make a note of the unique Tender ID assigned to each tender, in case they want to obtain any clarification / help from the Helpdesk.

PREPARATION OF BIDS:

- (x) For preparation of bid Bidders shall search the tender from published tender list available on site and download the complete tender document and should take into account corrigendum if any published before submitting their bids.
- (xi) After selecting the tender document same shall be moved to the 'My favorite' folder of bidders account from where bidder can view all the details of the tender document.
- (xii) Bidder shall go through the tender document carefully to understand the documents required to be submitted as part of the bid. Bidders shall note the number of covers in which the bid documents have to be submitted, the number of documents – including the names and content of each of the document that need to be submitted. Any deviations from these may lead to rejection of the bid.
- (xiii) Any pre-bid clarifications if required, then same may be obtained online through the tender site, or through the contact details given in the tender document.
- (xiv) Bidders should get ready in advance the bid documents in the required format (PDF/xls/rar/dwf/jpg formats) to be submitted as indicated in the tender document/schedule. **Bid documents may be scanned with 100 dpi with black and white option which helps in reducing size of the scanned document.**
- (xv) Bidders can update well in advance, the documents such as experience certificates, annual report, PAN, EPF & other details etc., under "My Space/ Other Important Document" option, which can be submitted as per tender requirements. This will facilitate the bid submission process faster by reducing upload time of bids.

SUBMISSION OF BIDS:

- (xvi) Bidder should log into the site well in advance for bid submission so that he/ she upload the bid in time i.e. on or before the bid submission time. Bidder will be responsible for any delay due to other issues.
- (xvii) Bidder should prepare the Tender Fee and EMD as per the instructions specified in the NIT/ tender document. The details of the DD/BC/BG/ others physically sent, should tally with the details available in the scanned copy and the data entered during bid submission time. Otherwise the uploaded bid will be rejected.
- (xviii) While submitting the bids online, the bidder shall read the terms & conditions (of CPP portal) and accepts the same in order to proceed further to submit their bid.
- (xix) Bidders shall select the payment option as offline to pay the Tender Fee/ EMD and enter details of the DD/BC/BG/others.
- (xx) Bidder shall digitally sign and upload the required bid documents one by one as indicated in the tender document.
- (xxi) Bidders shall note that the very act of using DSC for downloading the tender document and uploading their offers is deemed to be a confirmation that they have read all sections and pages of the tender document without any exception and have understood the complete tender document and are clear about the requirements of the tender document.
- (xxii) Bid documents may be scanned with 100 dpi with black and white option which helps in reducing size of the scanned document. For the file size of less than 1 MB, the transaction uploading time will be very fast.
- (xxiii) **If price quotes are required in XLS format, utmost care shall be taken for uploading Schedule of quantities & Prices and any change/ modification of the price schedule shall render it unfit for bidding.**
Bidders shall download the Schedule of Quantities & Prices i.e. Schedule-A, in XLS format and save it without changing the name of the file. Bidder shall quote their rate in figures in the appropriate cells, thereafter save and upload the file in financial bid cover (Price bid) only.
If the template of Schedule of Quantities & Prices file is found to be modified/corrupted in the eventuality by the bidder, the bid will be rejected and further dealt as per provision of clause no 23.0 of ITB including forfeiture of EMD. The bidders are cautioned that uploading of financial bid elsewhere i.e. other than in cover 2 will result in rejection of the tender.

- (xxiv) Bidders shall submit their bids through online e-tendering system to the Tender Inviting Authority (TIA) well before the bid submission end date & time (as per Server System Clock). **The TIA will not be held responsible for any sort of delay or the difficulties faced during the submission of bids online by the bidders at the eleventh hour.**
- (xxv) After the bid submission (i.e. after Clicking “Freeze Bid Submission” in the portal), the bidders shall **take print out of system generated acknowledgement** number, and keep it as a record of evidence for online submission of bid, which will also act as an entry pass to participate in the bid opening.
- (xxvi) Bidders should follow the server time being displayed on bidder’s dashboard at the top of the tender site, which shall be considered valid for all actions of requesting, bid submission, bid opening etc., in the e-tender system.
- (xxvii) All the documents being submitted by the bidders would be encrypted using PKI (Public Key Infrastructure) encryption techniques to ensure the secrecy of the data. The data entered cannot be viewed by unauthorized persons until the time of bid opening. The confidentiality of the bids is maintained using the secured Socket Layer 128-bit encryption technology.

ASSISTANCE TO BIDDERS:

- (i) Any queries relating to the tender document and the terms and conditions contained therein should be addressed to the Tender Inviting Authority for a tender or the relevant contract person indicated in the tender. The contact number for the **ALIMCO Toll Free Number 1800-1805129** between 10:00 hrs. to 17:00 hrs.
- (ii) Any queries relating to the process of online bid submission or queries relating to CPP Portal in general may be directed to the directed to the **ALIMCO Toll Free Number 1800-1805129**
- (iii) If any query is not resolved by the CPP Portal Helpdesk, you may contact the Nodal Officer (procurement), ALIMCO at +91-**9766681016**.

INVITATION TO QUOTE

Fax : 0512-2770671
Phone : 2770174
Email: dgm_mm@alimco.in
Website: www.alimco.in

GSTIN No.: 09AABCA8899F1Z6

ARTIFICIAL LIMBS MANUFACTURING CORPORATION OF INDIA
(A GOVERNMENT OF INDIA UNDERTAKING)
AN ISO 9001: 2008 COMPANY
G. T. ROAD, KANPUR – 209217

M/s

Enquiry No.	: MM/LT/89/AW
Date	: 27.12.2018
End Date	: 17.01.2018

Dear Sir,

Online quotations are invited for the supply of the following stores strictly as per our specifications (where applicable) for the quantities and the staggered Delivery Schedule as indicated below and as per the terms & conditions mentioned overleaf, to reach us by 1500 hrs. on or before the due date: -

01	ALIMCO Code No.		Total Qty./Unit	
	Description Of Stores	As per ANNEXURE 'A'		
	Delivery Schedule	Qty./Date	-	-
	ALIMCO Code No.		Total Qty./Unit	
	Description Of Stores	<p>Note:</p> <ol style="list-style-type: none"> 1. Kindly submitted duly SIGNED & STAMPED Sample (free of cost) separately for each offered items mentioning Make of each items. If the samples not submitted along with the offer by the tender, such Offer shall not be considered & summarily be rejected. 2. The basic price/rate, GST, Packing & Forwarding charges and Freight charges must be mentioned separately & Specifically. The offer quoted Inclusive of GST Taxes, may not consider for further processing. 3. Subsequent to placement of Purchase Order, the successful tenderer will be required to deposit a sum equal to 5% of the ordered value subject to a maximum of ` 50.00 lakh as Security Deposit in the form of Demand Draft or Pay Order or Bankers Cheque only in favour of ALIMCO payable at Kanpur for due discharge of the Purchase Order. 4. Maximum period required to commence supplies which may normally be not exceeding 30 days from the date of placement of Purchase Order. 5. This is fixed price tender. Any request for rate revision till currency of P.O shall not be considered. 6. Jigs, Fixture & Dies for manufacture of the above items required, if any, is to be developed by the party at their own cost. 7. The tentative quantities likely to be covered by Purchase Order are indicated above. The material would be required to be supplied on staggered delivery schedules to be indicated in Purchase Order or as required by the Corporation. 8. The total requirement of the above material may vary substantially up or down as per requirement of the Corporation & successful tenderer will be required to arrange the supplies accordingly. 9. The tentative monthly requirement will be approx. 1/12th of the quantity indicated above subject to be change by the Corporation which may vary substantially up or down as per requirement of the Corporation. 		

For Artificial Limbs Manufacturing Corpn. of India

(Materials Dept.)

Note: -

- (i) In case of any such requirement the corporation will be entitled to place repeat order on the same rate, terms & conditions subject to mutual consent.
- (ii) The Corporation has right to amend the Tender/Purchase Order quantity (enhanced/reduced) in case of change/amendment in the Production schedule during currency of Purchase Order to meet out the Corporation's target/commitments as per customer's/marketing department requirement.

TERMS AND CONDITIONS

A-1. Submission of Tenders– The detailed tender documents may be downloaded from <http://eprocure.gov.in/eprocure/app> till the last date of submission of tender. The Tender may be submitted online through CPP Portal

A-2. The bidder should submit the bid online in two parts viz. Technical Bid and Financial/Price Bid.

A-3. Technical Bid: Signed and Scanned copy of the Technical bid documents as under must be submit

Online on CPP Portal: <http://eprocure.gov.in/eprocure/app> .

a. List of Documents to be scanned and uploaded (Under Cover 1) within the period of bid submission: -

- i. EMD by way of Demand Draft or Banker's Cheque. SSI/MSE Units having valid registration with Udyog Aadhar Memorandum (UAM) for category of items as against this tender will be exempted from payment of EMD. Such SSI/MSE Tenderers are required to enclose/upload (under cover 1) a certified copy of valid registration certificate of Udyog Addhaar Memorandum which is mandatory to avail the exemption clearly showing the category of item. If the Registration is for the category of Item other than what has been Tendered by the Corporation, the exemption from EMD will not be allowed/admissible and tenderer needs to submit full amount of EMD as per tender alongwith their TC-Bid only to avoid summarily rejection of their offer.

The tenderer claiming EMD exemption based on Udyog Aadhar Memorandum (UAM) certificate are required to submit and undertaking (please refer Annexure –B) along with their quote/offer that the items quoted/offered are only for registered items/category of items as have been mentioned in the valid Udyog Aadhar Memorandum (UAM) certificate and submitting quote contrary (full or part) to the undertaking will cause summarily rejection of their quote/offer. (If Applicable at Annexure A)

ii. Scanned copy of GSTIN Registration Certificate, duly signed & stamped.

iii. Scanned copy of Annexure III duly filled and sign regarding submission of sample.

iv. Scanned copy of undertaking as per Annexure 'B' duly signed & stamped.

v. Scanned copy of tender acceptance letter, duly signed & stamped (As per Annexure 'C')

A-4. Financial / Price Bid

a. The currency of all quoted rates shall be Indian Rupees. All payment shall be made in Indian Rupees.

b. In preparing the financial bids, bidders are expected to take into account the requirements and conditions laid down in this Tender document. The financial bids should be uploaded online as per the specified ".xls" format i.e. **Annexure-D.xls** in Excel sheet attached as '.xls' with the tender and based on the scope of work, service conditions and other terms of the Tender document. It should include all costs associated with the Terms of Reference/Scope of Work of the assignment.

c. The basic price/rate, Packing & Forwarding charges and Freight charges must be mentioned separately & specifically. The offer quoted Inclusive of Packing & Forwarding Charges and freight charges may not be considered for further processing.

d. The Financial bid should be according to the. Xls format given in the Tender Document. It should be ensured that no required value against an item is missed. If the bidder does not want to charge for an item, the value must be filled as "0" (ZERO).

- (ii) Validity of Tenders – (a) The tenders shall remain open for acceptance for a minimum period of 90 days from the date of opening of tenders or till such period up to which the extension of validity is agreed to mutually. This may be please be stipulated clearly in the quotation. (b) If notified within this period that the tender has been accepted the tenderer shall be bound by the terms of the offer along with the terms that have been agreed to mutually. (c) All tenders without proper specification, samples, drawings and testing certificates. Where required, are liable to be rejected. It shall be in interest of tenderer that complete offer is made for our consideration.

3. **Details of offer** – (a) The Quoted rates shall be; FOR delivery at our Kanpur Factory, the following data shall be invariable furnished: - (i) Basic firm price of stores (ii) packing and forwarding charges, if any; (ii) Freight Charges. (b) In the case of quotations from local parties, the following rates shall be indicated specifically: - (i) Rate for delivery at the ALIMCO Factory.

4. The GST Tax applicable shall clearly be indicated in % as well as Rupees. Our GSTIN No is 09AABCA8899F1Z6.
5. D.G.S. and D Rate Contract – (a) Wherever the stores/equipment have been covered by the D.G.S and D rate contracts, the price shall conform to the same. A copy of current rate contract shall be enclosed for our ready reference. (b) Wherever the stores have not been covered under the D.G.S& D contract but under the rate contract of any State Stores Purchase Organization/Directorate of Industries, the price shall conform to the same. A copy of the current rate contract shall be enclosed for our ready reference.
6. Quantity Discounts – In order to submit the most competitive offer, the tenderer may indicate the quantity discount on a “slab basis” applicable on the price. However, the buyer reserves the right to accept the quantity discounts. The quantities indicated in this enquiry are liable to revision either upwards or downwards.
7. Delivery – (a) In their own interest, tenderers are advised to quote for the earliest possible delivery. Where ex-stock delivery’s quoted stock shall be held by the tenderer during the validity period quotation. (b) The delivery of the stores/equipment shall be made strictly as stipulated. Failure to supply within this period make the tenderers liable on to an unconditional penalty of ½% of the price of the goods in arrears per week subject to a maximum limit of 10% of value of the goods in arrears.
8. Terms & Payment – (a) Ours is a Government of India Undertaking registered under Section 25 of the Indian Companies Act 1956. As such the following terms of payment are stipulated: -
 - (i) 100% within 30 days after receipt of the stores/equipment without any damage/short supplies.
 - (ii) The GST portion shall be paid only after submission of proof / self-certified copy of GST Quarterly Return (GSTR-1) filed online by the tenderer clearly (duly highlighted) showing invoice/ bill number and amount to be submitted to ALIMCO so as to enable the Corporation to avail GST input credit after matching of the GST return and Invoice submitted in the Corporation. In case, non-matching no payment of GST shall be made.
9. Important instructions – (a) Where the item offered is not as per our specified make/size, the reason for not offering the same (e.g. not in ready stock etc.) shall be clearly indicated. (b) Please quote for free delivery at our factory site. However, Packing and Forwarding Charges wherever applicable shall be given clearly in % and Rupees.
10. Opening of Tenders – The tenders shall be opened at 15.30 hours on the specified bid Opening date in presence of representatives of tenderer who may like to be present.
11. Tenderers should indicate their GST Registration No. in their quotations, failing which their offer will not be considered.
12. **ALIMCO reserves the right to split up the total order quantity to more than 01 bidders to avoid stock out situation wherever necessary. In case of split up to 3 parties, 60% qty. may be placed on L-1 and 20% each on L-2 & L-3 provided they agree to match the rate with L-1 and in case of split up to 2 parties 60% qty. may be placed on L-1 and 40% on L-2 provided L-2 agree to match the rate with L-1.**
14. If any dispute/question or controversy arises, the settlement of which is not herein specifically provided in this Tender/Order/Contract, the matter in dispute shall be referred to the arbitration of Chairman and Managing Director of ALIMCO Or his nominee and decision of Chairman and Managing Director or his nominee shall be final and binding on both the parties. The provision of INDIAN ARBITRATION & CONCILLATION ACT 1956 as amended from time to time shall apply to such arbitration proceedings. Arbitration proceeding shall be held at Kanpur only and Kanpur Nagar Court will have jurisdiction in the matter.

ANNEXURE 'A'

Tender No. : MM/LT/89/AW
Date of Opening : 18.01.2019
Item : "Bicycle Hub, Free Balls & Other Bicycle Items"

SL No	Code No.	Nomenclature	Estimated Required Quantity	Amount of DD to be Enclosed along with TC bid towards EMD
1.	HK02	Free Ball dia 1/8" IS: 2898 Steel	6459 Gross	N/A
2.	HK03	Free Ball dia 5/32" IS: 2898 Steel	3056 Gross	
3.	HK05	Free Ball dia 3/16" IS: 2898 Steel	1264 Gross	
4.	HK06	Free Ball dia 1/4" IS: 2898 Steel	5000 Gross	
5.	HK12	Free Ball dia 7.0mm IS: 2898 Steel	15000 Nos.	
6.	LB52	Bicycle Bottom Head Ball Racer 1/8" (Set Of Three) Hardness-50-60 HRC. Wt-40 Grams MIN. IS:2973	15000 Nos.	
7.	LB56	Bicycle Top Head Screwed Racer 1/8" Hardness -50-60 HRC, THICK 6.3 MIN B.C.P, IS:2973	15000 Nos.	
8.	LC51	Bicycle front Hub Assy. (32 Holes) for 28" x 1 1/2" Wheel, Phillip Type, As per IS: 12205 (Nickel-Chromium Plated As per IS: 1068) As per ALIMCO Drg.	10000 Nos.	
9.	LC04	Hub Axle Assy (Front Wheel) 16" x 1 3/8" 10 Holes on each flange (20 holes) IS:629 Ni. Cr. Plated (As per ALIMCO Drg)	3000 Nos.	

Note:-

- Kindly submit free & non returnable Samples 01 Kit/Set of your each offered item/s along with the Offer (TC-Bid) duly tagged, stamped & signed with Name of Tenderer and Tender Number for proper and exact identification of samples. If the same is not complied, the Tenderer cannot deny the sample identified by us as their sample & the inspection report of the same.
- If the sample required as above is / are not submitted along with TC-BID, No subsequent opportunity will be given to submit the sample.
- Jigs, Fixtures & Dies for manufacture of the above items required, if any, is to be developed by the party at their own cost.
- This is a fixed price tender. Any request for rate revision till currency of P.O. shall not be considered.
- The tentative quantities likely to be covered by Purchase Order are indicated above. The material would be required to be supplied on staggered delivery schedule to be indicated in Purchase Order or as required by the Corporation.
- The total requirement of the above material may vary substantially up or down as per requirement of the Corporation & successful tenderer will be required to arrange the supplies accordingly.
- The tentative monthly requirement will be approx 1/12th of the quantity indicated above subject to be change by the Corporation which may vary substantially up or down as per requirement of the Corporation.
- Maximum period required to commence supplies which may normally be not exceeding 30 days from the date of placement of Purchase Order.
- The tenderers are required to provide the test certificates alongwith the supplies. The test certificate includes the chemical and mechanical properties, dimensions and other parameters as per drawing/specifications and applicable Indian Standard.
- All the traceable material test certificates from Govt./Accredited Agency/LAB must be provided by supplier with each supply. Also the material test certificate number must be endorsed in the respective Invoice of the material.

For Artificial Limbs Mfg. Corpn. of India

Dy. General Manager (Materials)

(TO BE FILLED UP IN DUPLICATE AND ENCLOSED WITH SAMPLES & TC BID)

LIST OF ITEMS BEING SUBMITTED

Tender No. :- MM/LT/89/AW

Date of Opening: - 18.01.2019

Name of Tenderer: - M/s. _____

Following items are being submitted as samples:-

<u>S.No.</u>	<u>Code No.</u>	<u>Description</u>	<u>Make /Brand</u>	<u>Qty.</u>	<u>Remarks</u>
1.					
2.					
3.					
4.					
5.					
6.					
7.					
8.					
9.					

Signature with seal & date

- Note:-**
1. Separate samples shall be submitted for each item if required as per Annexure 'A'.
 2. The samples should be submitted along with the offer (TC-Bid) duly tagged, stamped & signed with Name of Tenderer and Tender Number for proper and exact identification of samples. If the same is not complied, the Tenderer cannot deny the sample identified by us as their sample & the inspection report of the same.
 3. In case of non submission of sample, the Offer may be rejected.

ANNEXURE 'B'

UNDERTAKING

We hereby confirm that the material quoted/to be supplied is/will be as per ALIMCO Specification & Drawings.

We also hereby undertake to provide requisite Traceable Test Certificate (from OEM/any Govt. Lab/ NABL Accredited lab at the time of each supply and Invoices/Bills will bear relevant Test Certificate, reference no.

Dated:

Authorised Signatory:

Name :-

Designation :-

Seal :-

TENDER ACCEPTANCE LETTER
(To be given on Company Letter Head)

Date:

To,

Sub: Acceptance of Terms & Conditions of Tender.

Tender Reference No: _____

Name of Tender / Work: -

Dear Sir,

1. I / We have downloaded / obtained the tender document(s) for the above mentioned 'Tender/Work' from the web site(s) namely:

as per your advertisement, given in the above mentioned website(s).

2. I / We hereby certify that I / we have read the entire terms and conditions of the tender documents from Page No. _____ to _____ (including all documents like annexure(s), schedule(s), etc..), which form part of the contract agreement and I / we shall abide hereby by the terms / conditions / clauses contained therein.

3. The corrigendum(s) issued from time to time by your department/ organization too have also been taken into consideration, while submitting this acceptance letter.

4. I / We hereby unconditionally accept the tender conditions of above mentioned tender document(s) / corrigendum(s) in its totality / entirety.

5. I / We do hereby declare that our Firm has not been blacklisted/ debarred/ terminated/ banned by any Govt. Department/Public sector undertaking.

6. I / We certify that all information furnished by our Firm is true & correct and in the event that the information is found to be incorrect/untrue or found violated, then your department/ organization shall without giving any notice or reason therefore or summarily reject the bid or terminate the contract, without prejudice to any other rights or remedy including the forfeiture of the full said earnest money deposit absolutely.

Yours Faithfully,

(Signature of the Bidder, with Official Seal)

5 4 3 2 1

G
F
E
D
C
B
A

G
F
E
D
C
B
A

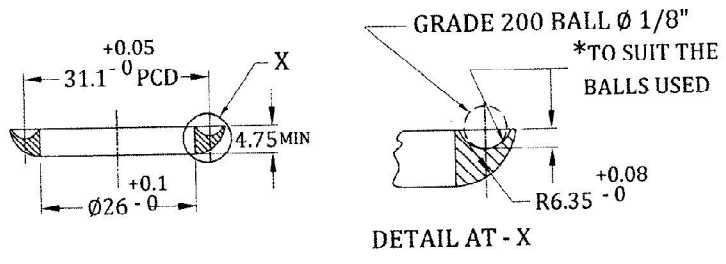

TOP AND BOTTOM INNER BALL RACE

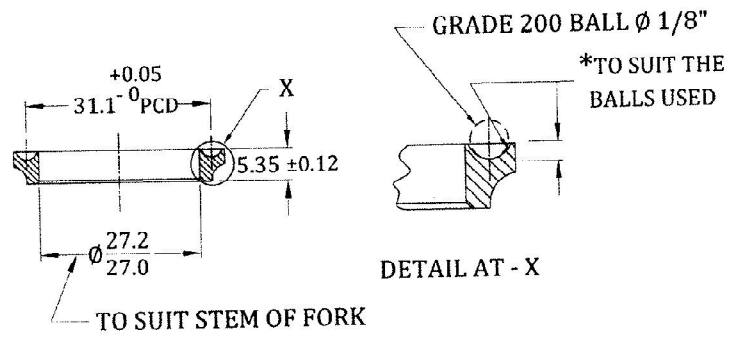

CROWN RACE

*SEATING SHAPE FOR BALLS MAY BE HEMISPHERICAL OR V - GROOVED.

- NOTE:-
 1. READYMADE AVAILABLE IS ACCEPTABLE.
 2. NO SHARP EDGES & CORNERS.
 3. WEIGHT - 40 gms. (APPROX).

3	---	DRAWING REDRAWN	24/12/99
SNo.	REGION	REVISION	DATE SIGN
REVISIONS			
		ARTIFICIAL LIMBS MANUFACTURING CORPORATION OF INDIA KANPUR	
DGN	<i>Qia</i>	NOM	BICYCLE CROWN BALL RACER 1/8". (SET OF THREE) HARDNESS 50-60 HRC, AS PER IS:2973
DRN	<i>Dubalk</i>	MTL	STEEL CONFORMING TO AS PER IS:226
CHD	<i>Qia</i>	TOL	INTEGER ONLY ±0.500 mm ONE PLACE DECIMAL ±0.250 mm TWO PLACE DECIMAL ±0.125 mm UNLESS SPECIFIED
DIM	IN mm	FIN	BRIGHT CHROME PLATED(B.C.P.)
SCALE	NTS	APP	<i>Qia</i>
06	K	6	086
DRG No:-	L B 52		SHEET 10F1
DATE	24-09-99		

5 4

25.4x1.06 PITCH
BICYCLE THREAD
1"x24 TPI

0.5x45°(TYP)

CHAMFERED OR RADIUS

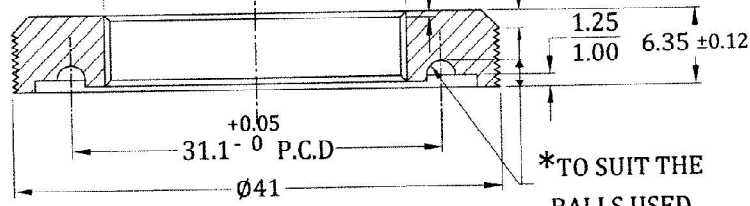

SECTION-XX

*TO SUIT THE
BALLS USED

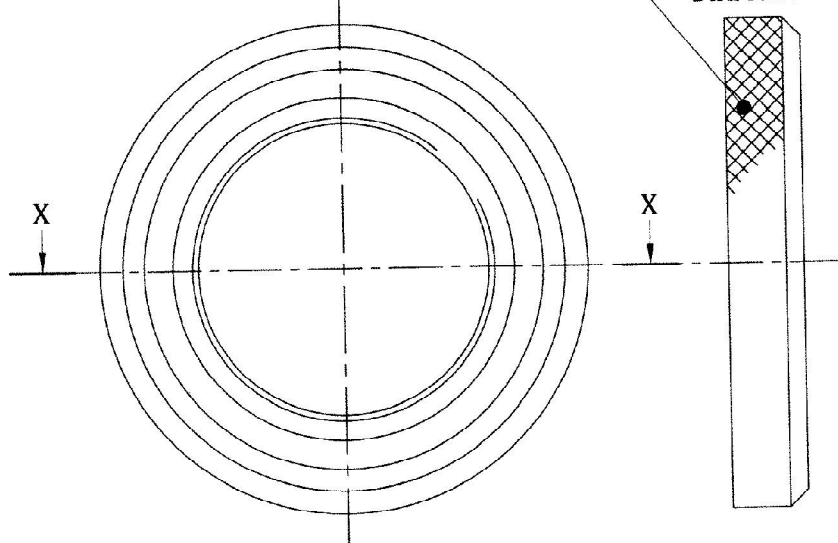

DIAMOND KNURLING



*SEATING SHAPE FOR BALLS MAY BE HEMISPHERICAL OR V - GROOVED

NOTE:-

1. READYMADE AVAILABLE IS ACCEPTABLE.
2. NO SHARP EDGES & CORNERS.
3. WEIGHT - 28 gms. (APPROX)

3	---	DRAWING REDRAWN	24 12/12
SNo.	REGION	REVISION	DATE SIGN
REVISIONS			
 ARTIFICIAL LIMBS MANUFACTURING CORPORATION OF INDIA KANPUR 			
DGN	<i>21am</i>	NOM	BICYCLE TOP HEAD SCREWED RACER 1/8", HARDNESS 50-60 HRC, THICK 6.3 MIN BCP, AS PER IS:2973
DRN	<i>Duphal</i>	MTL	STEEL CONFORMING AS PER IS:226
CHD	<i>21am</i>	TOL	INTEGER ONLY ±0.500 mm ONE PLACE DECIMAL ±0.250 mm TWO PLACE DECIMAL ±0.126 mm UNLESS SPECIFIED
DIM	IN mm	FIN	BRIGHT CHROME PLATED(B.C.P.)
SCALE	NTS	APP	
06	K 6	087	
DATE	24-09-99	DRG No:-	L B 56
			SHEET 10F1

06 K 6 087

5

4

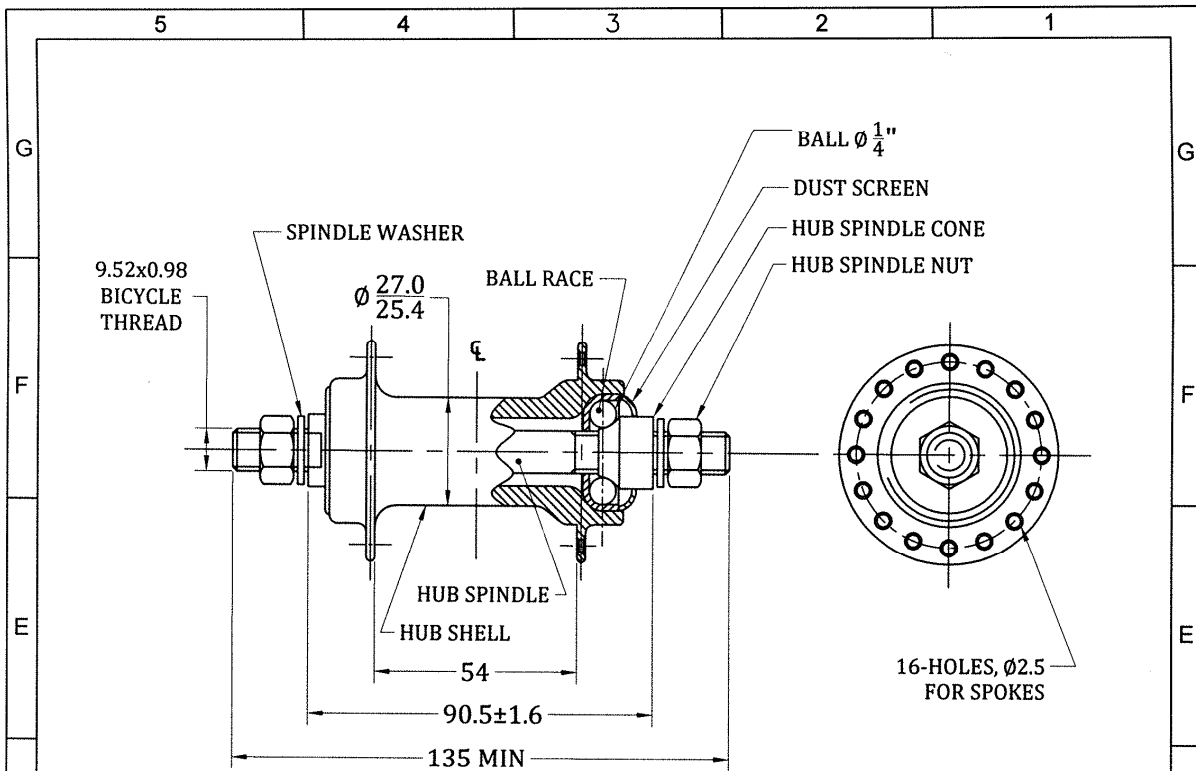

NOTE:—

1. HUB ASSY IS READILY AVAILABLE AS STANDARD BICYCLE SPARES.
2. DIMENSIONS (AS PER IS: 12205) ARE FOR REF. ONLY
3. WEIGHT-282 gms (APPROX)

6	E-4	DIMENSION 54 WAS 61	22.03.17	<i>SA/DD</i>
5	-----	DRAWING REDRAWN	31.01.13	<i>SA/DD</i>
SNo.	REGION	REVISION	DATE	SIGN

REVISIONS



ARTIFICIAL LIMBS
MANUFACTURING CORPORATION
OF INDIA
KANPUR



DGN	<i>Ashish</i>	NOM	BICYCLE FRONT HUB ASSY. (32 HOLES) FOR 28"x1½" WHEEL, PHILLIP TYPE AS PER IS:12205	
DRN	<i>SA/DD</i>	MTL		
CHD	<i>SA/DD</i>	TOL	INTEGER ONLY ±0.500 mm ONE PLACE DECIMAL ±0.250 mm TWO PLACE DECIMAL ±0.126 mm	UNLESS SPECIFIED
DIM	IN mm	FIN	NICKEL-CHROMIUM PLATED AS PER IS:1068	
SCALE	NTS	APP	<i>SA/DD</i>	
DATE	19.1.89	DRG No:-	LC 51	

06	K	6	037
5		4	

SHEET 10F1

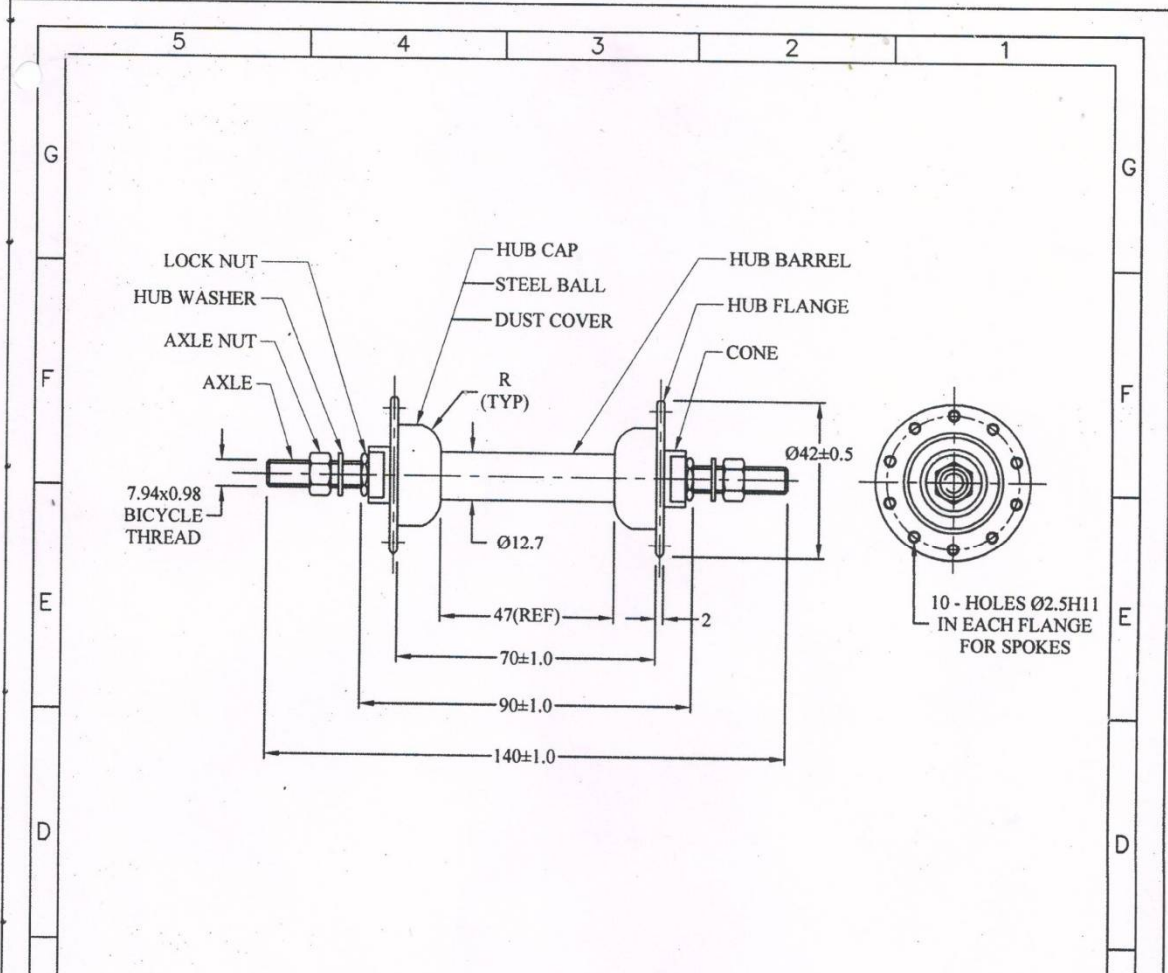

- NOTE:-
- HUB ASSY (R-TYPE) IS READILY AVAILABLE AS STANDARD BICYCLE SPARE.
 - DIMENSIONS (AS PER IS: 629) ARE FOR REF ONLY
 - WEIGHT-170 TO 180 gms.

TOLERANCE:-

DEVIATION FOR NON TOLERANCED DIMENSIONS (ISI:2102 MEDIUM)	
DIAMETER & LENGTHS BETWEEN	LENGTH IN MM OF SHORTER SIDE OF ANGLE UPTO & INCL.
0.5 up to 6	±0.1
Over 6 up to 30	±0.2
Over 30 up to 120	±0.3
Over 120 up to 315	±0.5
Over 315 up to 1000	±0.8
Over 1000 up to 2000	±1.2
Over 2000 up to 4000	±2.0
MACHINING FINISH IN MICRONS	
▽ 8 - 25	▽ 1.6 - 8
▽▽ 0.025 - 1.6	▽▽▽ <0.025

THIS DRAWINGS AND SPECIFICATION ARE THE PROPERTY OF ALIMCO AND SHALL NOT BE REPRODUCED OR COPIED WITHOUT PRIOR PERMISSION.

SNo.	REGION	REVISION	DATE	SIGN
REVISIONS				
ARTIFICIAL LIMBS MANUFACTURING CORPORATION OF INDIA KANPUR				
DGN	<i>Ashish</i>	NOM	HUB AXLE ASSY (FRONT WHEEL) 16"x1 3/8" 10-HOLES ON EACH FLANGE (20 HOLES) IS:629	
DRN	<i>Shaw</i>	MTL	HEAT TREATMENT	
CHD	<i>Shaw</i>	SURFACE TREATMENT	Ni. Cr. PLATED	
DIM	IN mm			
SCALE	NTS			
APP	<i>Shaw</i>	DRG No:-	LC 04	SHEET 1OF1
DATE	09.05.2017			