

## INVITATION TO QUOTE

### ALIMCO - AUXILIARY PRODUCTION CENTRE, ARTIFICIAL LIMBS MANUFACTURING CORPORATION OF INDIA

(A GOVT. OF INDIA UNDERTAKING "MINIRATNA" COMPANY)  
Plot No. 40 & 106, Industrial Area, Richhai, Jabalpur (M.P.) – 482010  
Telephone: 0761-2334717, 2334724, Web: www.alimco.in  
E-mail: aapc\_jabalpur@alimco.in, alimcoapcjb@gmail.com



**CIN: U85110UP1972NPL003646 // GSTIN: 23AABCA8899F1ZG**

M/s
-----

Enquiry No.	:	LT-04/JBP/AW/A
Dated	:	18/07/2018
Due Date	:	10/08/2018

Dear Sir,

**Sealed quotation are invited in rate format as specify in "Annexure-A" for the supply of the following stores strictly as per our specification /drawings (where applicable) for the quantities and the staggered Delivery Schedule as indicated and as per the terms & conditions mentioned overleaf, to reach us by 14:00 hrs. on or before the due date:-**

ALIMCO Code No.	Total Qty./Unit
01	AS PER ANNEXURE 'A'
Description of Stores	
Delivery Schedule	Qty./ Date
<b>Note (A):-</b>	<ol style="list-style-type: none"><li><b>The basic price/ rate, GST (If applicable), Packing &amp; Forwarding charges and Freight charges must be mentioned separately &amp; specifically. The offer quoted Inclusive of GST Taxes, Packing &amp; Forwarding Charges and freight charges may not consider for further processing.</b></li><li><b>Kindly mention GSTIN in your offer.</b></li><li>Maximum period required to commence supplies which may normally be not exceeding 30 days from the date of placement of Purchase Order.</li><li>This is fixed price tender. Any request for rate revision till currency of P.O shall not be considered.</li><li>Jigs, Fixture &amp; Dies for manufacture of the tendered items required, if any, is to be developed by the party at their own cost.</li><li>The tentative quantities likely to be covered by Purchase Order are indicated above. The material would be required to be supplied on staggered delivery schedules to be indicated in Purchase Order or as required by the Corporation.</li><li>The total requirement of the above material may vary substantially up or down as per requirement of the Corporation &amp; successful tenderer will be required to arrange the supplies accordingly.</li><li>The tentative monthly requirement will be approx. 1/12th of the quantity indicated above subject to be change by the corporation which may vary substantially up or down as per requirement of the corporation.</li></ol>

For: ALIMCO-Auxiliary Production Centre, Jabalpur

Material Management Deptt.

#### **Note (B):-**

**(i) Kindly mention the Enquiry No. and Due date on Envelop.**

(ii) In case of any such requirement the corporation will be entitled to place "Repeat Order" on the same rate, terms & conditions subject to mutual consent.

(iii) The corporation has right to amend the Tender/ Purchase Order quantity (enhanced/ reduced) in case of change/ amendment in the Production schedule during currency of Purchase Order to meet out the Corporation's target/ commitments as per customer's/ marketing department requirement.

**(iv) Tenderer/ Suppliers are requested to quote/ submit their offer FOR: "APC-ALIMCO, JABALPUR".**

## **TERMS AND CONDITIONS**

1. **Submission of Tenders** – (a) Tenders shall be sent in a sealed envelope super scribing the Enquiry No. & due date. (b) Tender shall be addressed to "Materials Department, ALIMCO-Auxiliary Production Centre, Plot No. 40 & 106, Industrial Area, Richhai, Jabalpur – 482010 (M.P.)". (c) The Tenderers may at their discretion send the Tenders by Registered/Speed Post Acknowledgement Due, but postal and transit delay shall not be necessarily considered in reckoning the tenders for our consideration.
2. **Validity of Tenders** – (a) The tenders shall remain open for acceptance for a minimum period of 90 days from the date of opening of tenders or till such period upto which the extension of validity is agreed to mutually. This may be please be stipulated clearly in the quotation. (b) If notified within this period that the tender has been accepted the tenderer shall be bound by the terms of the offer along with the terms that have been agreed to mutually. (c) All tenders without `proper specification, samples, drawings and Testing certificates, where required, are liable to be rejected. It shall be in interest of tenderer that are complete offer is made for our consideration.
3. **Details of offer** – (a) **The quoted rates shall be Quoted FOR delivery at our Jabalpur Factory the following data shall be invariable furnished :- (i) Basic firm price of stores; (ii) GST, if any applicable; (iii) packing and forwarding charges, if any; (iv) Freight Charges. (b) In the case of quotations from local parties, the following rates shall be indicated specifically:- (i) Rate for delivery at the APC-ALIMCO, Jabalpur Factory, (ii) Rate for delivery Ex-shop/ Ex-Go down JABALPUR.**
4. **Taxes:** – The GST Tax applicable shall clearly be indicated in percentage. Our GSTIN is 23AABCA8899F1ZG.
5. **DGS&D Rate Contract** – (a) Wherever the stores/equipments have been covered by the DGS&D rate contracts, the price shall conform to the same. A copy of current rate contract shall be enclosed for our ready reference. (b) Wherever the stores have not been covered under the DGS&D contract but under the rate contract of any State Stores Purchase Organization/Directorate of Industries, the price shall conform to the same. A copy of the current rate contract shall be enclosed for our ready reference.
6. **Quantity Discounts** – In order to submit the most competitive offer, the tenderer may indicate the quantity discount on a "slab basis" applicable on the price. However, the buyer reserves the right to accept the quantity discounts. The quantities indicated in this enquiry are liable to revision either upwards or downwards.
7. **Delivery** –
  - (a) In their own interest, tenderers are advised to quote for the earliest possible delivery. Where Ex-stock delivery's quoted stock shall be held by the tenderer during the validity period of quotation.
  - (b) The delivery of the stores/equipment shall be made strictly as stipulated. Failure to supply within this period make the tenderers liable on to an unconditional penalty of  $\frac{1}{2}\%$  of the price of the goods in arrears per week subject to a maximum limit of **10%** of value of the goods in arrears.
  - (c) The supply of all items shall be completed satisfactorily within the stipulated delivery period of the order failing which ALIMCO reserves the right to obtain / purchase stores from other sources at your sole risk, responsibility and cost. If any higher price has to be paid above the contracted price, the loss which may occur on this account, shall be recovered from the tenderer.
  - (d) **The supplies shall be made in proper packing (in countable quantity) to avoid any damage/loss/pilferage in transit & storage.**
8. **Terms & Payment** – (a) Ours is a Government of India Undertaking registered under "Section 8" of the Indian Companies Act, 2013. As such the following terms of payment are stipulated:-
  - i) **100% payment within 30 days after receipt and acceptance of the materials/stores/equipment without any damage/short supplies after the submission of bill, whichever is later will be made. However, the GST portion will be payable only after submission of proof/ self-certified copy of GST return filed online by the tenderer clearly (duly highlighted) showing invoices/ bill number and amount submitted to ALIMCO.**
  - ii) **Acceptance of Payment Terms other than standard Payment Terms of within 30 days**, is at the discretion of management and in that case 1% of total landed cost will be considered additional while preparing Comparative Statement of Quotations (CSQ). However, Purchase Order will be placed at quoted rates.
  - iii) **Payment in Advance terms is not acceptable.**
9. **Important instructions** – (a) Where the item offered is not as per our specified make/size, the reason for not offering the same (e.g. not in ready stock etc.) shall be clearly indicated. (b) Please quote for delivery at our factory site. However, Packing and Forwarding, Freight Charges wherever applicable shall be given clearly in % in format at Annexure-'A'.
10. **Opening of Tenders** – The tenders shall be **opened at 15:00 hours on due date** in presence of representatives of tenderers who may like to be present.
11. ALIMCO reserves the right to split up the total order quantity to more than 01 bidder to avoid stock out situation wherever necessary. In case of split up to 3 parties, 60% qty. may be placed on L-1 and 20% each on L-2 & L-3 provided they agree to match the rate with L-1 and in case of split up 02 parties 60% of the Qty. may be placed on L-1 and 40% on L-2 provided L-2 agree to match the rate with L-1.
12. Offers for supplies other than FOR APC-ALIMCO, Jabalpur/ Ex-shop, Jabalpur / Ex-works, Jabalpur / FOR Jabalpur will be summarily rejected. However, offers for other than FOR APC-ALIMCO, Jabalpur but for Ex-shop, Jabalpur / Ex-works, Jabalpur / FOR Jabalpur shall be loaded by 2% of basic cost for working out the landed cost & comparison purposes in CSQ. However Purchase Order will be placed at quoted rates terms & conditions. But, the successful tender has to provide / offer duly packed material.
13. **The other terms & conditions of corporation's Purchase Policy shall be applicable.**
14. If any dispute/ question or controversy arises, the settlement of which is not herein specially provided in this Tender/ Order/ Contract, the matter in dispute shall be referred to the arbitration of Chairman and Managing Director of ALIMCO or his nominee and decision of Chairman and Managing Director or his nominee shall be final and binding on both the parties. The provision of INDIAN ARBITRATION & CONCILLATION ACT, 1956 as amended from time to time shall apply to such arbitration proceedings. Arbitration proceeding shall be held at Kanpur only and Kanpur nagar Court will have jurisdiction in the matter.

## Annexure - A

Sl. No.	ALIMCO Code No.	Description of Stores/ Nomenclature	Qty./ Unit	Basic Price ₹ (Per Unit)	Freight & packing/ forwarding etc. (in % only)	GST rates in terms of Percentage (%), if applicable	Tentative delivery schedule
01	TD2A07V02	PLATE BEARING UPPER (AS PER ALIMCO DRG.)	7500 Nos.				2500 nos per month
02	TD2A07A28	REST RAIL SEAT-REAR (AS PER ALIMCO DRG.)	4000 Nos.				2000 nos per month
03	TD2A07A25	BRACKET (AS PER ALIMCO DRG.)	5000 Nos.				2500 nos per month
04	TD2A07E03	STRIP FOLDING LEFT - FRONT (AS PER ALIMCO DRG.)	4500 Nos.				2000 nos per month
05	TD2A07E01	STRIP FOLDING LEFT (AS PER ALIMCO DRG.)	4500 Nos.				2000 nos per month
06	TD2A07D03	STRIP FOLDING -RIGHT (AS PER ALIMCO DRG.)	4500 Nos.				2000 nos per month
07	TD2A07D10	STRIP FOLDING RIGHT-FRONT (AS PER ALIMCO DRG.)	4500 Nos.				2000 nos per month
08	TD2A07E02	LINK LEFT (AS PER ALIMCO DRG.)	9000 Nos.				2000 nos per month
09	TD2A07D04	LINK RIGHT (AS PER ALIMCO DRG.)	7000 Nos.				2000 nos per month
10	TD2A07M13	LOCK NUT (AS PER ALIMCO DRG.)	8100 Nos.				2500 nos per month

### **Note:**

1. If the rate quoted is inclusive of GST, Freight and Packing & Forwarding etc. then offer shall be summarily rejected without any further clarification/notice.
2. **The rates should be quoted as per above format, if the offers/ quoted rates are not in above specified format same may not consider for further processing without any further information.**
3. The Tenderer/ Bidder needs to submit Annexure 'A' & Annexure 'B' alongwith the offer.

Seal & Signature

Party Name

**TENDER ACCEPTANCE LETTER**

(To be given on Tenderer/ Bidder's Letter Head)

Date: .....

To,  
In-charge/ Materials Department,  
APC-ALIMCO,  
Plot No. 40 & 106, Industrial Area, Richhai,  
Jabalpur-482010

Sub: Acceptance of Terms & Conditions of Tender.

Tender Reference No: \_\_\_\_\_

Name/ Code of Tendered items/ Work:- \_\_\_\_\_

Dear Sir,

1. I/ We hereby certify that I/ we have read the entire terms and conditions of the tender documents from Page No. \_\_\_\_\_ to \_\_\_\_\_ [including all documents like Annexure(s), Schedule(s), specification and drawing, etc.], which form part of the contract agreement and I/ we shall abide hereby by the terms/ conditions /clauses contained therein.
2. The corrigendum(s) issued from time to time by your department/ organization too have also been taken into consideration, while submitting this acceptance letter.
3. I/ We hereby unconditionally accept the tender conditions of above mentioned tender document(s)/ corrigendum(s) in its totality/ entirety.
4. I/ We do hereby declare that our Firm has not been blacklisted/ debarred/ terminated/ banned by any Govt. Department/ Public sector undertaking.
5. I/ We certify that all information furnished by our Firm is true & correct and in the event that the information is found to be incorrect/ untrue or found violated, then your department/ organization shall without giving any notice or reason therefore or summarily reject the bid or terminate the contract, without prejudice to any other rights or remedy including the forfeiture of the full said earnest money deposit absolutely.

Yours Faithfully,

(Signature of the Party/ Bidder, with Official Seal)

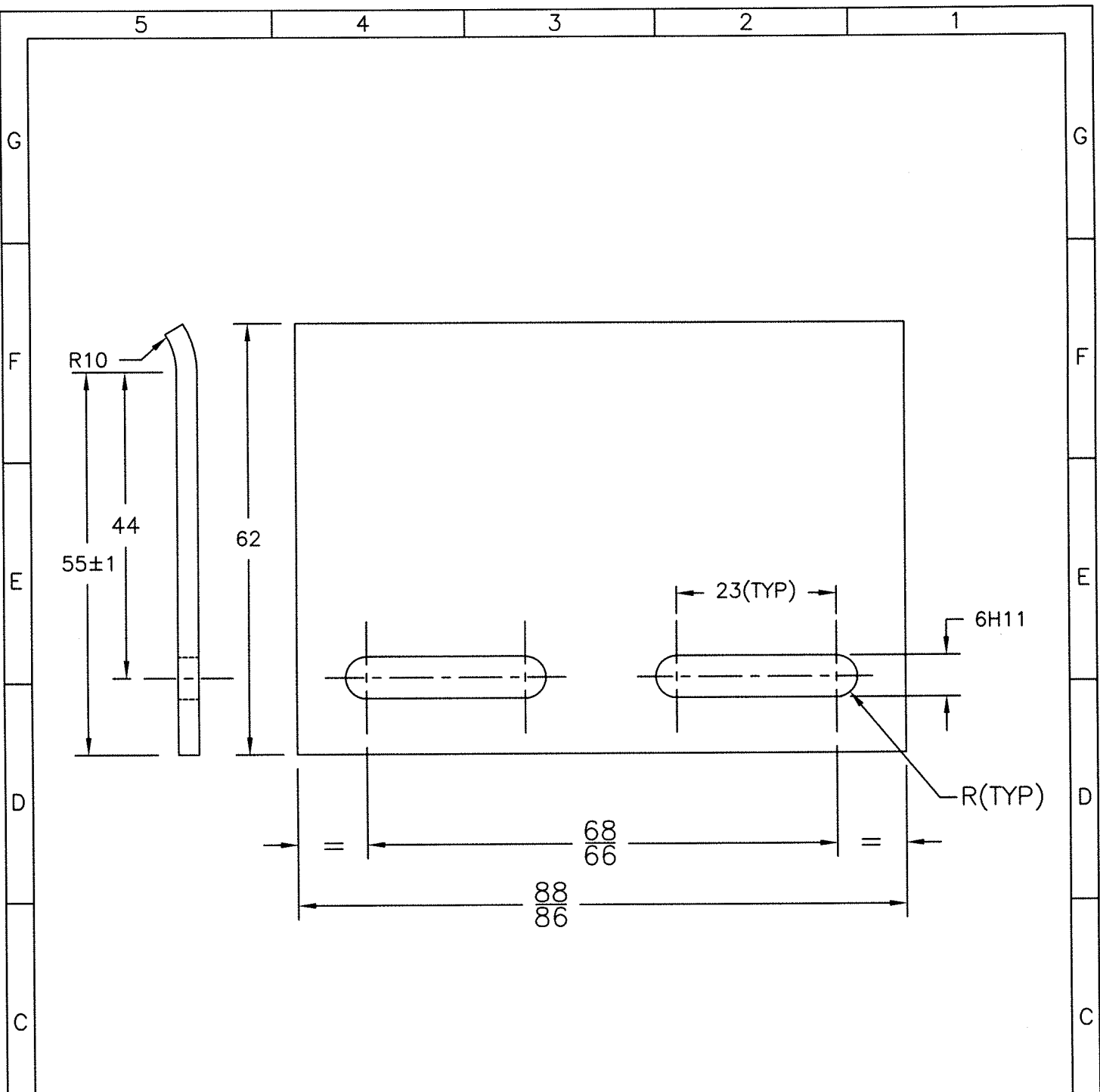

NOTE:---

1.REMOVE SHARP EDGES & CORNERS.

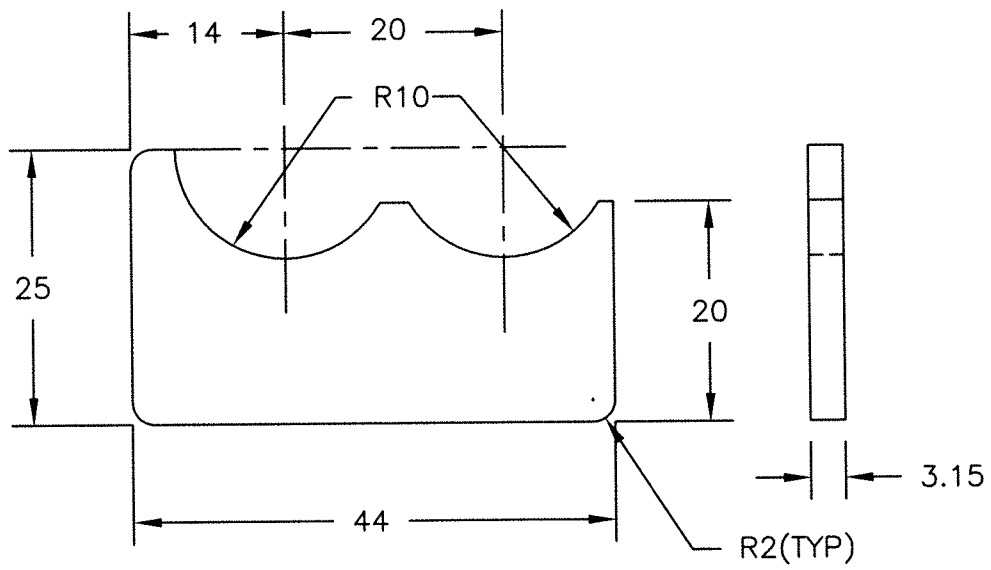

2.	---	DRAWING REDRAWN	14.01.15	<i>Raw</i>
SN0.	REGION	REVISION	DATE	SIGN
R E V I S I O N S				
		ARTIFICIAL LIMBS MANUFACTURING CORPORATION OF INDIA KANPUR		
DGN		NOM	BRACKET	
DRN	<i>Ashish</i>	MTL	SHEET MS HRA Gd'0'IS:1079 THK3.15mm(AA08)	
CHD	<i>Raw</i>	TOL	INTEGER ONLY ±0.500 mm ONE PLACE DECIMAL ±0.250 mm TWO PLACE DECIMAL ±0.126 mm	UNLESS SPECIFIED
DIM	IN mm	FIN	---	
SCALE	NTS			
APP	<i>Sa/DD 1</i>			
DATE	10.05.1983			
			DRG No: -TD 2 A 07 A 25	
			SHEET 10F1	

01	K	5	189
		5	4



NOTE:---

1. REMOVE SHARP EDGES & CORNERS.

1.	---	DRAWING REDRAWN	14.01.15	<i>Das</i>
SNo.	REGION	REVISION	DATE	SIGN
R E V I S I O N S				
		ARTIFICIAL LIMBS MANUFACTURING CORPORATION OF INDIA KANPUR		
				
DGN		NOM	REST RAIL SEAT(REAR)	
DRN	<i>Ashish</i>	MTL	SHEET MS HRA Gd'0' IS:1079 THK3.15mm (AA08)	
CHD	<i>(Signature)</i>	TOL	INTEGER ONLY ±0.500 mm ONE PLACE DECIMAL ±0.250 mm TWO PLACE DECIMAL ±0.126 mm	UNLESS SPECIFIED
DIM	IN mm	FIN	---	
SCALE	NTS			
01	K	8	096	APP <i>Sa/DD1</i>
5		4		DATE 25.01.1985
DRG No:--TD 2 A 07 A. 28				SHEET 10F1

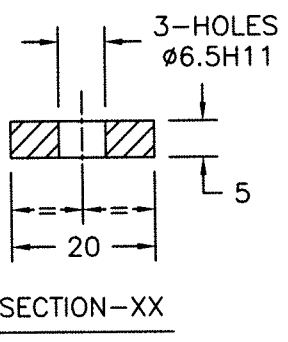
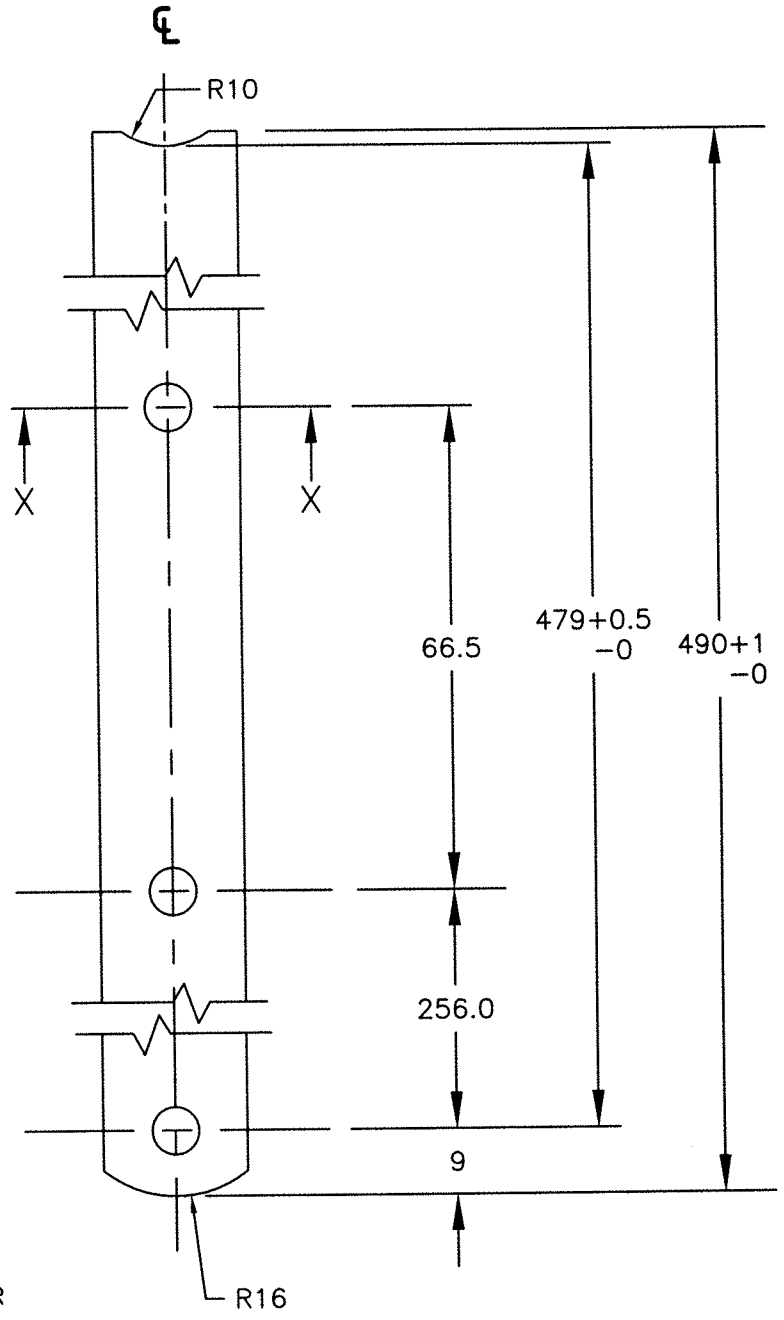



MTL:--

SHEET MS HOT ROLLED ANNEALED  
Gd'o' IS:1079, THICK 5mm (AA10)  
OR  
FLAT MS 5X20mm St42-S, IS:226 OR  
FLAT MS 3/16 X 3/4 (AD 26)

NOTE:--

1. REMOVE SHARP EDGES & CORNERS.
2. WEIGHT - 340gms(APPROX)

5.	---	DRAWING REDRAWN	12.02.15	<i>Glax</i>
SNo.	REGION	REVISION	DATE	SIGN
R E V I S I O N S				
 ARTIFICIAL LIMBS MANUFACTURING CORPORATION OF INDIA KANPUR 				
DGN	<i>Ashish</i>	NOM	STRIP FOLDING RIGHT	
DRN	<i>Rajeev</i>	MTL	INDICATED	
CHD	<i>Rajeev</i>	TOL	INTEGER ONLY ±0.500 mm ONE PLACE DECIMAL ±0.250 mm TWO PLACE DECIMAL ±0.126 mm	UNLESS SPECIFIED
DIM	IN mm	FIN	BUFF SMOOTH	
SCALE	NTS	APP	DRG No:- TD 2 A 07 D 03	
APP	<i>S.L./DDI</i>	DATE	23.10.1978	SHEET 10F1

01 K 5 033

5 4

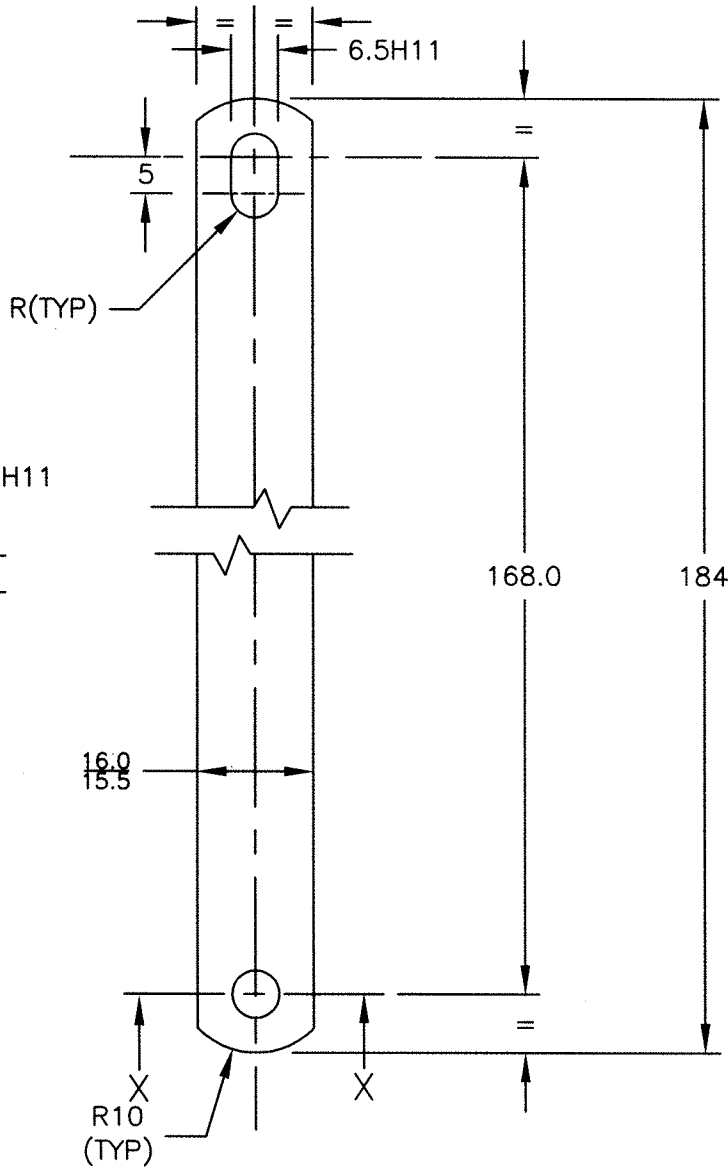

SECTION-XX

MTL:--

SHEET MS HRA Gd'0' IS:1079,  
THICK 5mm (AA10)  
OR  
FLAT MS 5X16mm St42-S, IS:226 OR  
FLAT MS  $\frac{3}{16}$  X  $\frac{3}{4}$  (AD 26)

NOTE:--

1. REMOVE SHARP EDGES & CORNERS.
2. WEIGHT - 120gms(APPROX)

9.	---	DRAWING REDRAWN	12.02.15	<i>[Signature]</i>
SNo.	REGION	REVISION	DATE	SIGN

REVISIONS



ARTIFICIAL LIMBS  
MANUFACTURING CORPORATION  
OF INDIA  
KANPUR



DGN	<i>[Signature]</i>	NOM	LINK RIGHT	
DRN	<i>[Signature]</i>	MTL	INDICATED	
CHD	<i>[Signature]</i>	TOL	INTEGER ONLY	±0.500 mm
DIM	IN mm		ONE PLACE DECIMAL	±0.250 mm
SCALE	NTS		TWO PLACE DECIMAL	±0.126 mm
APP	<i>[Signature]</i>	FIN	TD 2 A 07-Ni.Cr. PLATED Gd'2', IS:1068	
DATE	23.10.1978		TD 2 A 08-POWDER COATED COLOUR AS APPD.	
DRG No:-- TD 2 A 07 D 04			SHEET 10F1	

01 K 5 034

5

4



5 4 3 2 1

G  
F  
E  
D  
C  
B  
A

G  
F  
E  
D  
C  
B  
A

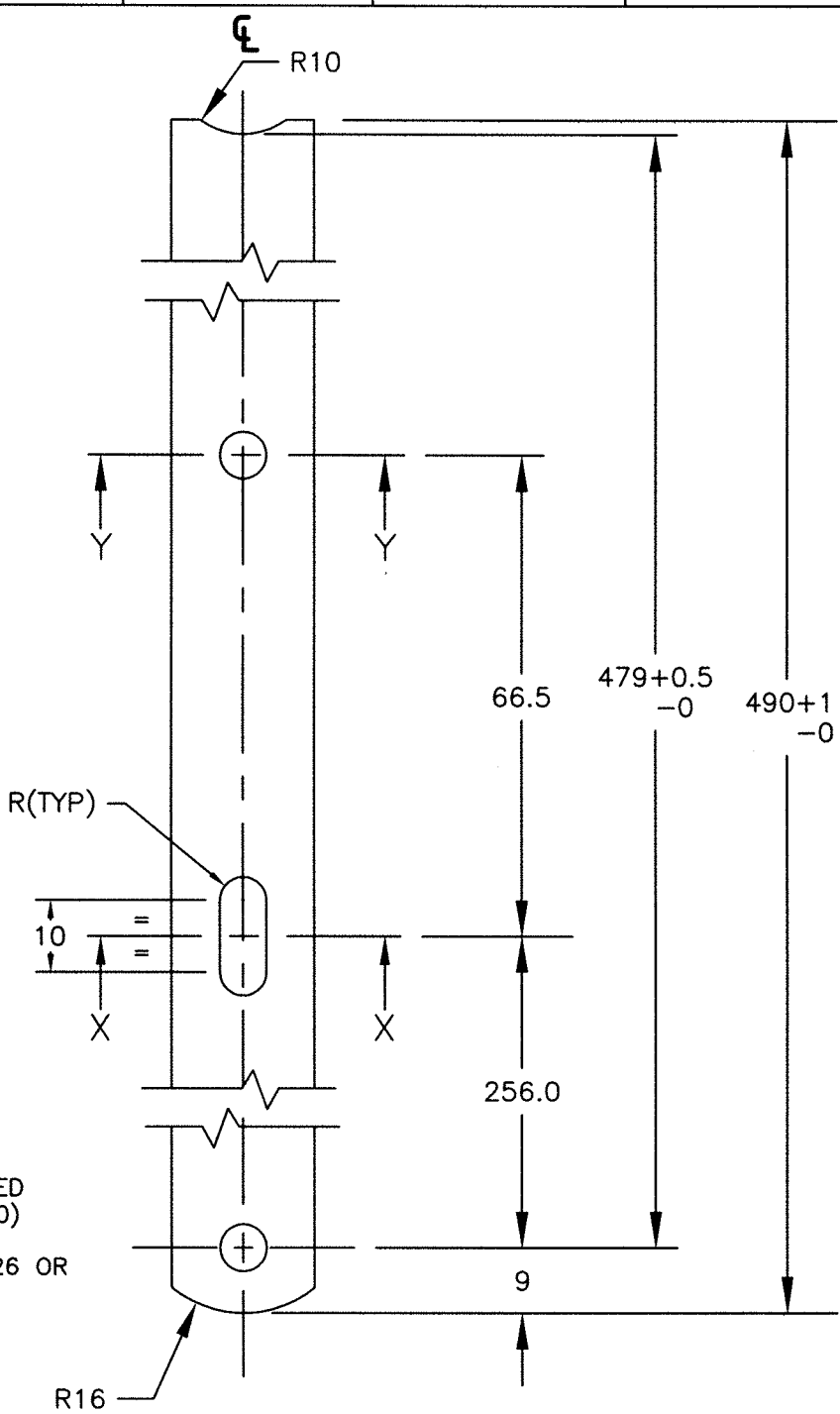
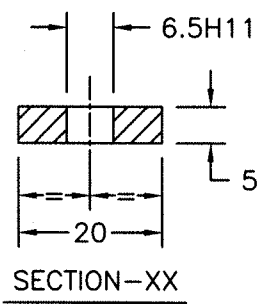
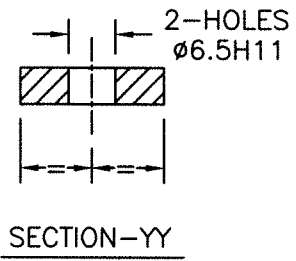

MTL:---

SHEET MS HOT ROLLED ANNEALED  
Gd'O' IS:1079, THICK 5mm (AA10)  
OR  
FLAT MS 5X20mm St42-S, IS:226 OR  
FLAT MS 3/16 X 3/4 (AD 26)

NOTE:---

1. REMOVE SHARP EDGES & CORNERS.
2. THE COMPONENT IS SIMILAR TO TD 2 A 07 D 03 EXCEPT THE SLOT.
3. WEIGHT - 340gms(APPROX)

3.	---	DRAWING REDRAWN	12.02.15	<i>Raj</i>
SNo.	REGION	REVISION	DATE	SIGN

REVISIONS



ARTIFICIAL LIMBS  
MANUFACTURING CORPORATION  
OF INDIA  
KANPUR



DGN	<i>Abhishek</i>	NOM	STRIP FOLDING RIGHT(FRONT)	
DRN	<i>Raj</i>	MTL	INDICATED	
CHD	<i>Raj</i>	TOL	INTEGER ONLY ±0.500 mm	UNLESS SPECIFIED
DIM	IN mm		ONE PLACE DECIMAL ±0.250 mm	
			TWO PLACE DECIMAL ±0.126 mm	
SCALE	NTS	FIN	BUFF SMOOTH	

01	K	5	372
5			4

APP	<i>Sd/DDI</i>	DRG No:- TD 2 A 07 D 10	SHEET 10F1
DATE	09.05.1990		

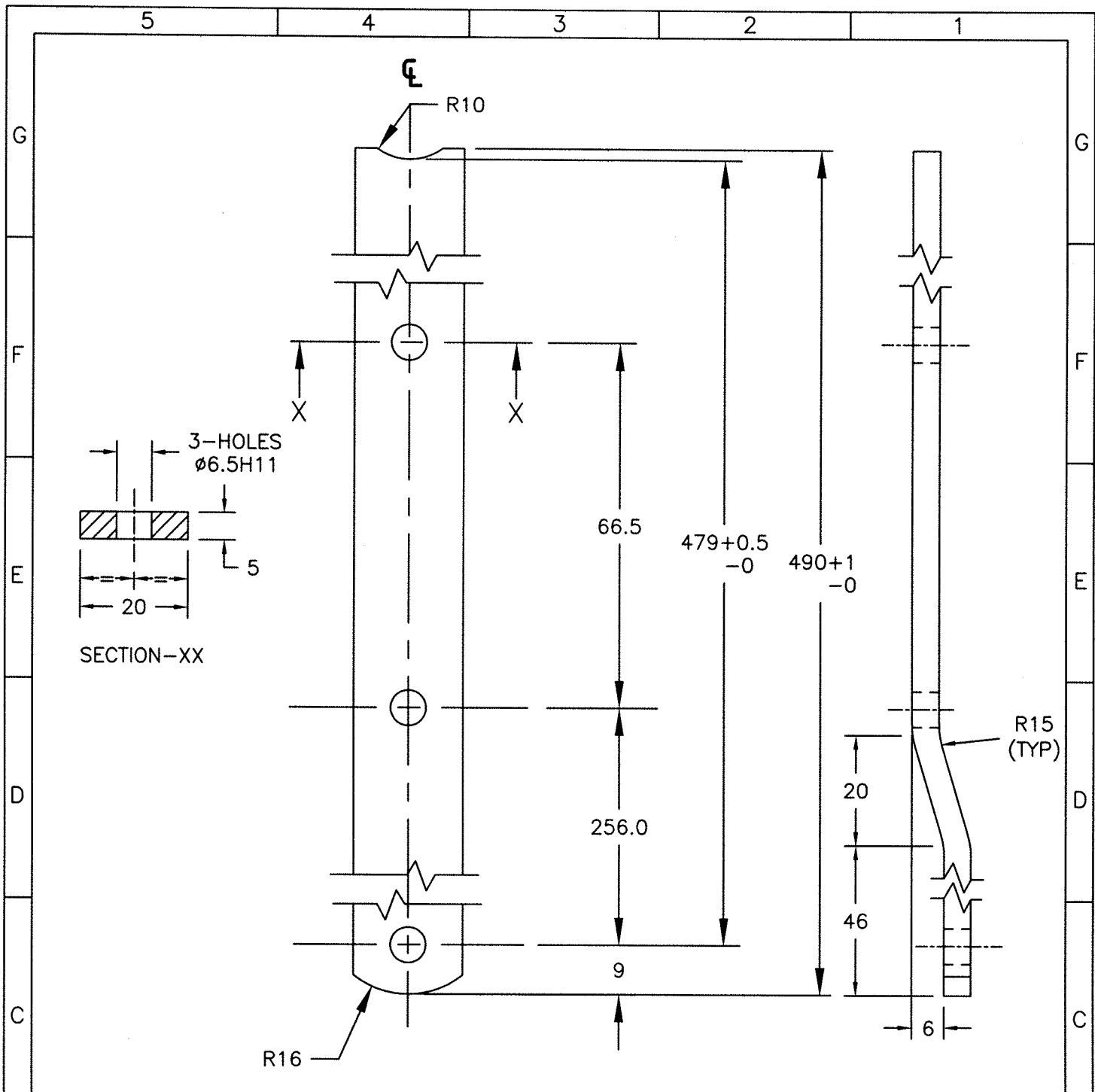

NOTE:---

1. REMOVE SHARP EDGES & CORNERS.
2. WEIGHT - 340gms(APPROX)

MTL:---

SHEET MS HOT ROLLED ANNEALED  
Gd'0' IS:1079, THICK 5mm (AA10)  
OR  
FLAT MS 5X20mm St42-S, IS:226 OR  
FLAT MS  $\frac{3}{16}$  X  $\frac{3}{4}$  (AD 26)

5.	---	DRAWING REDRAWN	12.02.15	<i>Raj</i>
SNo.	REGION	REVISION	DATE	SIGN
R E V I S I O N S				
		ARTIFICIAL LIMBS MANUFACTURING CORPORATION OF INDIA KANPUR		
DGN	<i>Ashish</i>	NOM	STRIP FOLDING LEFT	
DRN		MTL	INDICATED	
CHD	<i>Raj</i>	TOL	INTEGER ONLY ±0.500 mm ONE PLACE DECIMAL ±0.250 mm TWO PLACE DECIMAL ±0.126 mm	UNLESS SPECIFIED
DIM	IN mm	FIN	BUFF SMOOTH	
SCALE	NTS $\frac{1}{1}$			
APP	<i>Sd/DDI</i>	DRG No:- TD 2 A 07 E 01		SHEET 10F1
DATE	23.10.1978			

01	K	5	037
5		4	

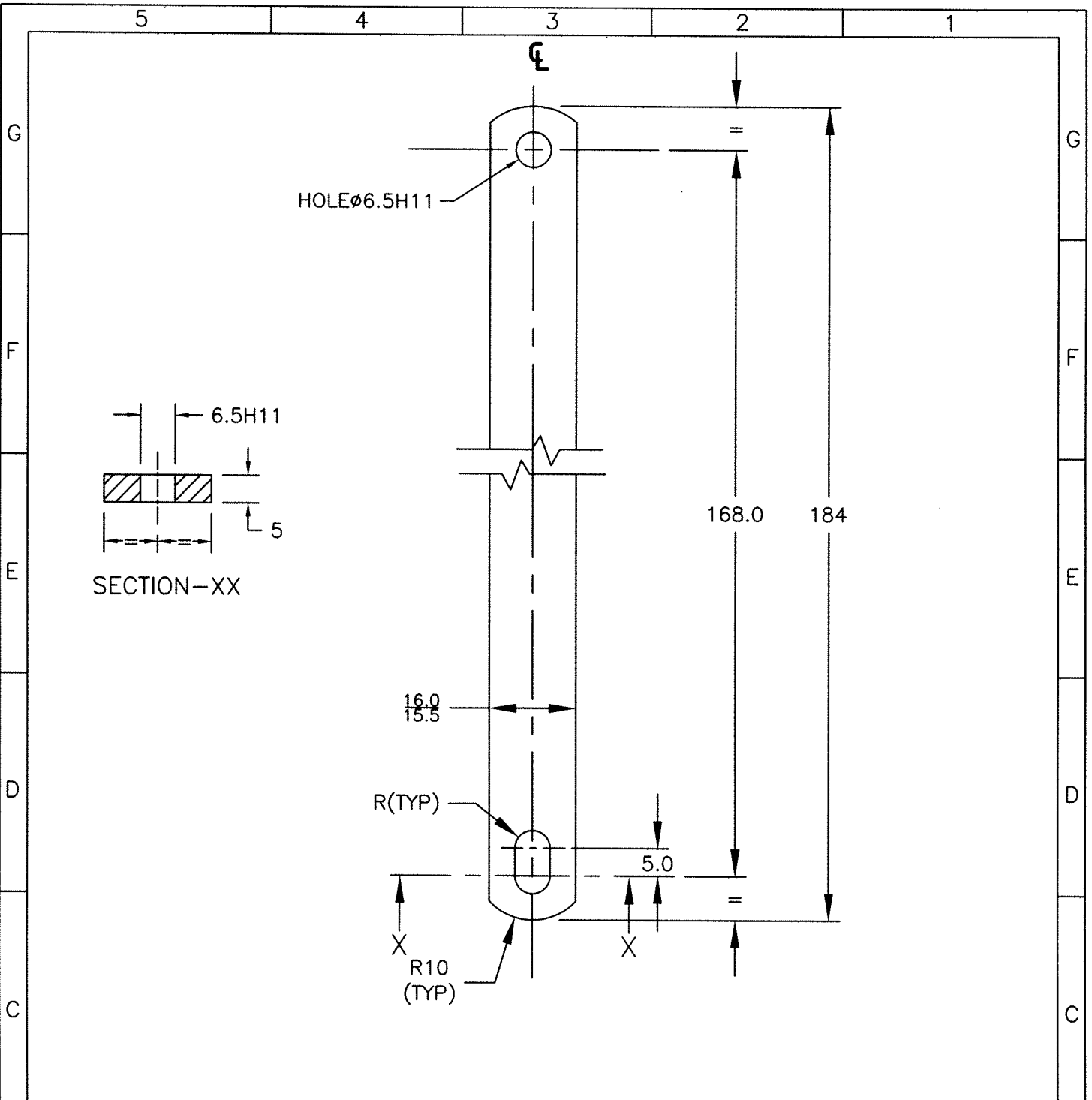



NOTE:---

1. REMOVE SHARP EDGES & CORNERS.
2. WEIGHT - 120gms (APPROX)

MTL:---

SHEET MS HRA Gd'0' IS:1079,  
THICK 5mm (AA10)  
OR  
FLAT MS 5X16mm St42-S, IS:226 OR  
FLAT MS 3/16 X 3/4 (AD 26)

9.	---	DRAWING REDRAWN	12.02.15	<i>gla</i>
SNo.	REGION	REVISION	DATE	SIGN
R E V I S I O N S				
 <b>ARTIFICIAL LIMBS</b> <b>MANUFACTURING CORPORATION</b> <b>OF INDIA</b> <b>KANPUR</b> 				
DGN	<i>Abhis</i>	NOM	LINK LEFT	
DRN		MTL	INDICATED	
CHD	<i>gla</i>	TOL	INTEGER ONLY ±0.500 mm ONE PLACE DECIMAL ±0.250 mm TWO PLACE DECIMAL ±0.126 mm	UNLESS SPECIFIED
DIM	IN mm	FIN	TD 2 A 07-Ni.Cr. PLATED Gd'2', IS:1068 TD 2 A 08-POWDER COATED COLOUR AS APPD.	
SCALE	NTS			
APP	<i>Sel/DDI</i>		DRG No:-- TD 2 A 07 E 02	SHEET 10F1
DATE	23.10.1978			

01	K	5	038
5			4

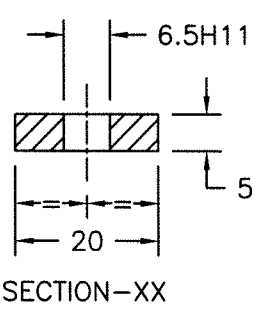
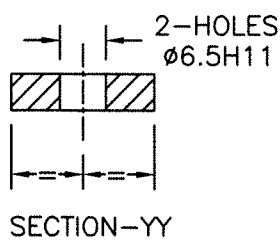
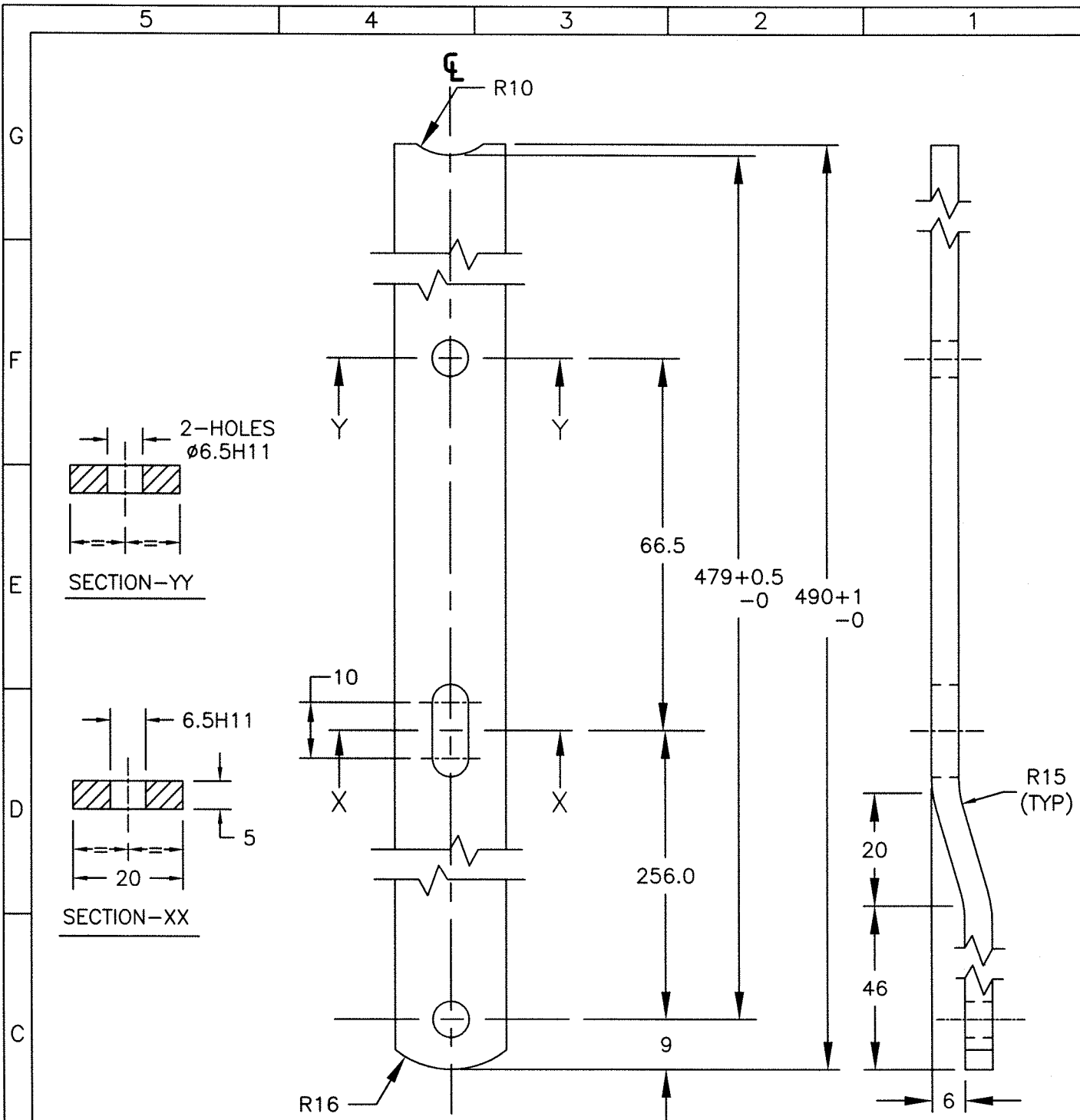

NOTE:---

1. REMOVE SHARP EDGES & CORNERS.
2. THE COMPONENT IS SIMILAR TO TD 2 A 07 E01 EXCEPT THE SLOT.
3. WEIGHT - 340gms(APPROX)

MTL:---

SHEET MS HOT ROLLED ANNEALED  
Gd'0' IS:1079, THICK 5mm (AA10)  
OR  
FLAT MS 5X20mm St42-S, IS:226 OR  
FLAT MS  $\frac{3}{16}$  X  $\frac{3}{4}$  (AD 26)

3.	---	DRAWING REDRAWN	12.02.15	<i>Draw</i>
SNo.	REGION	REVISION	DATE	SIGN
R E V I S I O N S				
		ARTIFICIAL LIMBS MANUFACTURING CORPORATION OF INDIA KANPUR		
DGN	<i>Ashish</i>	NOM	STRIP FOLDING LEFT(FRONT)	
DRN		MTL	---	
CHD	<i>Draw</i>	TOL	INTEGER ONLY ±0.500 mm	UNLESS SPECIFIED
DIM	IN mm		ONE PLACE DECIMAL ±0.250 mm	
			TWO PLACE DECIMAL ±0.126 mm	
SCALE	NTS	FIN	BUFF SMOOTH	
APP	<i>SD/001</i>	DRG No:-- TD 2 A 07 E 03		SHEET 10F1
DATE	09.05.1990			

B  
A

B  
A

01 K 5 373

5 4

9.52X0.98  
BICYCLE THREAD

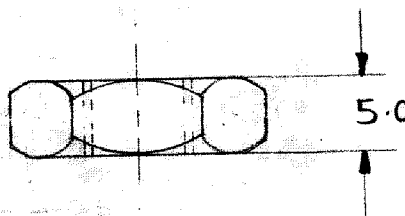
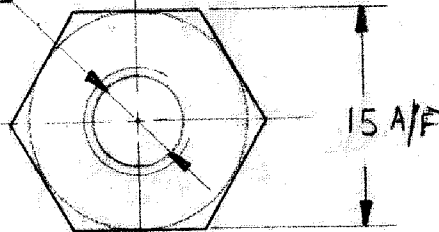

**NOTE:-**

1. NUT IS SIMILAR TO HUB SPINDLE NUT (IS: 629) -
2. READY MADE AVAILABLE IS ACCEPTABLE
3. REMOVE SHARP EDGES & CORNERS.
4. WEIGHT - 5 gms (APPROX).

1	A-5	WEIGHT OF COMPONENT ADDED AT NOTE No. 4	7.2.05	RES						
S.No.	REGION	REVISION	DATE	SIG.						
<b>R E V I S I O N S</b>										
<b>ARTIFICIAL LIMBS MANUFACTURING CORPN. OF INDIA KANPUR</b>										
DGN.	<i>R...</i>	NOM.	<b>LOCK NUT</b>							
DRN.	<i>Krishna</i>	MTL.	MS C.R.B.A. 13 S.25 (EN 1A EQUIVALENT) HEX. 15 A/F G.K.W. OR EQUIVALENT							
CHD.	<i>K...</i>	TOL.	<table border="0"> <tr> <td>INTEGER ONLY</td> <td>±0.500 mm</td> </tr> <tr> <td>ONE PLACE DECIMAL</td> <td>±0.250 mm</td> </tr> <tr> <td>TWO PLACE DECIMAL</td> <td>±0.125 mm</td> </tr> </table>		INTEGER ONLY	±0.500 mm	ONE PLACE DECIMAL	±0.250 mm	TWO PLACE DECIMAL	±0.125 mm
INTEGER ONLY	±0.500 mm									
ONE PLACE DECIMAL	±0.250 mm									
TWO PLACE DECIMAL	±0.125 mm									
DIM.	IN mm	FIN.	ZINC PLATED THICKNESS 6 TO 8 MICRONS							
SCALE	1:1	<b>DRG. NO. TD 2A 07 M 13</b>								
APP.	<i>[Signature]</i>									
DATE	18.2.78	SHEET 01								

01 K 5 0 6 9

5 4 3 2 1

G G

F F

E E

D D

C C

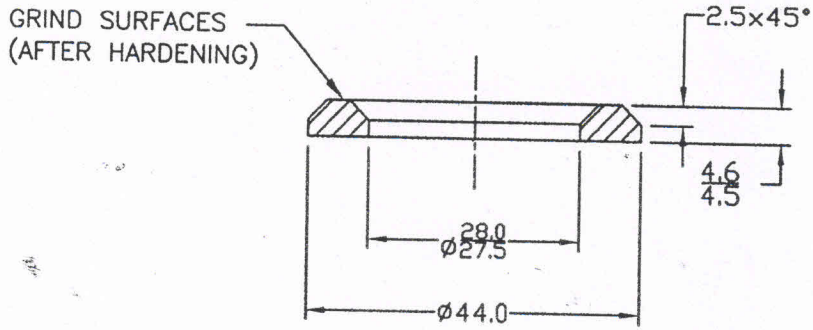
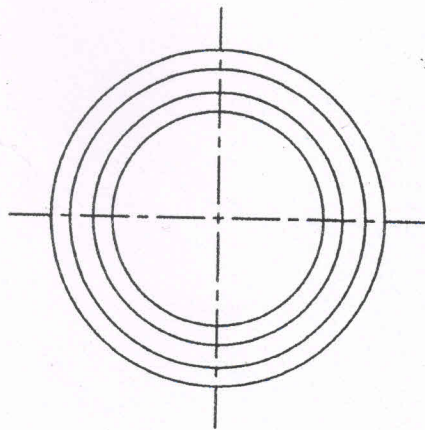

MTL:-  
 Rod Carbon Steel C 55 (EN9),  
 Ø45mm, IS:1570 (Pt-II) (AH 31)  
 OR  
 Plate Carbon Steel C 55 (EN9),  
 Thick 5mm, IS:1570 (Pt-II) (AH 36)

NOTE:-  
 1. Hardened & Tempered -  
 Hardness 35-40 HRC.  
 2. Weight 30 TO 35gms.

24 MAY 2018

TOLERANCE:-

DEVIATION FOR NON TOLERANCED DIMENSIONS  
 (ISI:2102 MEDIUM)

DIAMETER & LENGTHS BETWEEN	LENGTH IN MM OF SHORTER SIDE OF ANGLE UPTO & INCL.	TOLERANCE
0.5 up to 6	Up to 10	±0.1 ±1°00'
Over 6 up to 30	Over 10 upto 50	±0.2 ±0°30'
Over 30 up to 120	Over 50 upto 120	±0.3 ±0°20'
Over 120 up to 315	Over 120 upto 400	±0.5 ±0°10'
Over 315 up to 1000		±0.8
Over 1000 up to 2000		±1.2
Over 2000 up to 4000		±2.0

MACHINING FINISH IN MICRONS  
 ▽ 8 - 25 ▽ 1.6 - 8 ▽ 0.025 - 1.6 ▽ 0.0125 - 0.025

THIS DRAWINGS AND SPECIFICATION ARE THE PROPERTY OF ALIMCO AND SHALL NOT BE REPRODUCED OR COPIED WITHOUT PRIOR PERMISSION.

5	D - 5	MTL AH 31 OR AH 36 WERE AH 13 OR AL 11	28.10.17	
4	—	DRAWING REDRAWN	07.09.18	
SNo.	REGION	REVISION	DATE	SIGN

REVISIONS

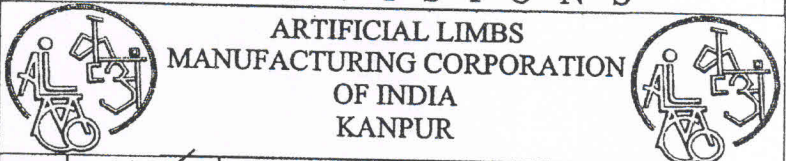

DGN	ALM	NOM	PLATE BEARING UPPER
DRN	ALM	MTL	INDICATED
CHD	ALM	HEAT TREATMENT	INDICATED
DIM	IN mm	SURFACE TREATMENT	MACHINED & GROUND
SCALE	NTS	DRG No:-	TD 2 A 07 V 02
APP	Sd/DD1	REV	5
DATE	11.04.1981	SHEET	10F1

5 4