

INVITATION TO QUOTE

ALIMCO - AUXILIARY PRODUCTION CENTRE, ARTIFICIAL LIMBS MANUFACTURING CORPORATION OF INDIA

(A GOVT. OF INDIA UNDERTAKING "MINIRATNA" COMPANY)
Plot No. 40 & 106, Industrial Area, Richhai, Jabalpur (M.P.) – 482010
Telephone: 0761-2334717, 2334724, Web: www.alimco.in
E-mail: aapc_jabalpur@alimco.in



CIN: U85110UP1972NPL003646 // GSTIN: 23AABCA8899F1ZG

M/s

Enquiry No.	:	LT-32/JBP/AW
Dated	:	11-01-2019
Due Date	:	31-01-2019

Dear Sir,

Sealed quotation are invited in rate format as specify in "Annexure-A" for the supply of the following stores strictly as per our specification /drawings (where applicable) for the quantities and the staggered Delivery Schedule as indicated and as per the terms & conditions mentioned overleaf, to reach us by 14:00 hrs. on or before the due date:-

ALIMCO Code No.	Total Qty./Unit		
01		<u>AS PER ANNEXURE 'A'</u>	
Description of Stores			
Delivery Schedule	Qty./ Date		
Note (A):-	<ol style="list-style-type: none">1. The basic price/ rate, GST (If applicable), Packing & Forwarding charges and Freight charges must be mentioned separately & specifically. The offer quoted Inclusive of GST Taxes, Packing & Forwarding Charges and freight charges may not consider for further processing.2. Kindly mention GSTIN in your offer.3. Maximum period required to commence supplies which may normally be not exceeding 30 days from the date of placement of Purchase Order.4. This is fixed price tender. Any request for rate revision till currency of P.O. shall not be considered.5. Jigs, Fixture & Dies for manufacture of the tendered items required, if any, is to be developed by the party at their own cost.6. The tentative quantities likely to be covered by Purchase Order are indicated above. The material would be required to be supplied on staggered delivery schedules to be indicated in Purchase Order or as required by the Corporation.7. The total requirement of the above material may vary substantially up or down as per requirement of the Corporation & successful tenderer will be required to arrange the supplies accordingly.8. The tentative monthly requirement will be approx. 1/12th of the quantity indicated above subject to be change by the corporation which may vary substantially up or down as per requirement of the corporation.		

For: ALIMCO-Auxiliary Production Centre, Jabalpur

Material Management Deptt.

Note (B):-

(i) Kindly mention the Enquiry No. and Due date on Envelop.

(ii) In case of any such requirement the corporation will be entitled to place "Repeat Order" on the same rate, terms & conditions subject to mutual consent.

(iii) The corporation has right to amend the Tender/ Purchase Order quantity (enhanced/ reduced) in case of change/ amendment in the Production schedule during currency of Purchase Order to meet out the Corporation's target/ commitments as per customer's/ marketing department requirement.

(iv) Tenderer/ Suppliers are requested to quote/ submit their offer FOR: "APC-ALIMCO, JABALPUR".

TERMS AND CONDITIONS

1. **Submission of Tenders** – (a) Tenders shall be sent in a sealed envelope super scribing the Enquiry No. & due date. (b) Tender shall be addressed to "Materials Department, ALIMCO-Auxiliary Production Centre, Plot No. 40 & 106, Industrial Area, Richhai, Jabalpur – 482010 (M.P.)". (c) The Tenderers may at their discretion send the Tenders by Registered/Speed Post Acknowledgement Due, but postal and transit delay shall not be necessarily considered in reckoning the tenders for our consideration.
2. **Validity of Tenders** – (a) The tenders shall remain open for acceptance for a minimum period of 90 days from the date of opening of tenders or till such period upto which the extension of validity is agreed to mutually. This may be please be stipulated clearly in the quotation. (b) If notified within this period that the tender has been accepted the tenderer shall be bound by the terms of the offer along with the terms that have been agreed to mutually. (c) All tenders without `proper specification, samples, drawings and Testing certificates, where required, are liable to be rejected. It shall be in interest of tenderer that are complete offer is made for our consideration.
3. **Details of offer** – (a) **The quoted rates shall be Quoted FOR delivery at our Jabalpur Factory the following data shall be invariable furnished :- (i) Basic firm price of stores; (ii) GST, if any applicable; (iii) packing and forwarding charges, if any; (iv) Freight Charges. (b) In the case of quotations from local parties, the following rates shall be indicated specifically:- (i) Rate for delivery at the APC-ALIMCO, Jabalpur Factory, (ii) Rate for delivery Ex-shop/ Ex-Go down JABALPUR.**
4. **Taxes:** – The GST applicable shall clearly be indicated in percentage. Our GSTIN is 23AABCA8899F1ZG.
5. **DGS&D Rate Contract** – (a) Wherever the stores/equipments have been covered by the DGS&D rate contracts, the price shall conform to the same. A copy of current rate contract shall be enclosed for our ready reference. (b) Wherever the stores have not been covered under the DGS&D contract but under the rate contract of any State Stores Purchase Organization/Directorate of Industries, the price shall conform to the same. A copy of the current rate contract shall be enclosed for our ready reference. (c) All SSI units / Micro & Small Enterprises (MSE) will be issued Tender Documents free of cost & Exemption to submit Earnest Money Deposit (EMD) on submission of valid Udyog Aadhar Memorandum (UAM) against Tender for the items/nature of business/ type of services specified therein in the UAM.
6. **Quantity Discounts** – In order to submit the most competitive offer, the tenderer may indicate the quantity discount on a "slab basis" applicable on the price. However, the buyer reserves the right to accept the quantity discounts. The quantities indicated in this enquiry are liable to revision either upwards or downwards.
7. **Delivery** –
 - (a) In their own interest, tenderers are advised to quote for the earliest possible delivery. Where Ex-stock delivery's quoted stock shall be held by the tenderer during the validity period of quotation.
 - (b) The delivery of the stores/equipment shall be made strictly as stipulated. Failure to supply within this period make the tenderers liable on to an unconditional penalty of $\frac{1}{2}\%$ of the price of the goods in arrears per week subject to a maximum limit of **10%** of value of the goods in arrears.
 - (c) The supply of all items shall be completed satisfactorily within the stipulated delivery period of the order failing which ALIMCO reserves the right to obtain / purchase stores from other sources at your sole risk, responsibility and cost. If any higher price has to be paid above the contracted price, the loss which may occur on this account, shall be recovered from the tenderer.
 - (d) **The supplies shall be made in proper packing (in countable quantity) to avoid any damage/loss/pilferage in transit & storage.**
8. **Terms & Payment** – (a) Ours is a Government of India Undertaking registered under "Section 8" of the Indian Companies Act, 2013. As such the following terms of payment are stipulated:-
 - i) **100% payment within 30 days after receipt and acceptance of the materials/stores/equipment without any damage/short supplies after the submission of bill, whichever is later will be made. However, the GST portion will be payable only after submission of proof/ self-certified copy of GST return filed online by the tenderer clearly (duly highlighted) showing invoices/ bill number and amount submitted to ALIMCO.**
 - ii) **Acceptance of Payment Terms other than standard Payment Terms of within 30 days, is at the discretion of management and in that case 1% of total landed cost will be considered additional while preparing Comparative Statement of Quotations (CSQ). However, Purchase Order will be placed at quoted rates.**
 - iii) **Payment in Advance terms is not acceptable.**
9. **Important instructions** – (a) Where the item offered is not as per our specified make/size, the reason for not offering the same (e.g. not in ready stock etc.) shall be clearly indicated. (b) Please quote for delivery at our factory site. However, Packing and Forwarding, Freight Charges wherever applicable shall be given clearly in % in format at Annexure-'A'.
10. **Opening of Tenders** – The tenders shall be **opened at 15:00 hours on due date** in presence of representatives of tenderers who may like to be present.
11. ALIMCO reserves the right to split up the total order quantity to more than 01 bidder to avoid stock out situation wherever necessary. In case of split up to 3 parties, 60% qty. may be placed on L-1 and 20% each on L-2 & L-3 provided they agree to match the rate with L-1 and in case of split up 02 parties 60% of the Qty. may be placed on L-1 and 40% on L-2 provided L-2 agree to match the rate with L-1.
12. **Offers for supplies other than FOR APC-ALIMCO, Jabalpur/ Ex-shop, Jabalpur / Ex-works, Jabalpur / FOR Jabalpur will be summarily rejected. However, offers for other than FOR APC-ALIMCO, Jabalpur but for Ex-shop, Jabalpur / Ex-works, Jabalpur / FOR Jabalpur shall be loaded by 2% of basic cost for working out the landed cost & comparison purposes in CSQ. However Purchase Order will be placed at quoted rates terms & conditions. But, the successful tender has to provide / offer duly packed material.**
13. **The other terms & conditions of corporation's Purchase Policy shall be applicable.**
14. If any dispute/ question or controversy arises, the settlement of which is not herein specially provided in this Tender/ Order/ Contract, the matter in dispute shall be referred to the arbitration of Chairman and Managing Director of ALIMCO or his nominee and decision of Chairman and Managing Director or his nominee shall be final and binding on both the parties. The provision of INDIAN ARBITRATION & CONCILLATION ACT, 1956 as amended from time to time shall apply to such arbitration proceedings. Arbitration proceeding shall be held at Kanpur only and Kanpur Nagar Court will have jurisdiction in the matter.

Tender No. LT-32/JBP/AW

Sl. No.	ALIMCO Code No.	Description of Stores/ Nomenclature	Qty./ Unit	Basic Price ₹ (Per Unit)	Freight & packing/ forwarding etc. (in % only)	GST rates in terms of Percentage (%), if applicable	Tentative delivery schedule
1	TD2A06H05	Washer Nylon (as per ALIMCO drg.)	15000 nos.		_____ %	_____ %	3750 nos. per month
2	TD2A06H06	Bearing Sleeve (as per ALIMCO drg.)	4000 nos.		_____ %	_____ %	1000 nos. per month
3	TD2A06H07	Washer (as per ALIMCO drg.)	8000 nos.		_____ %	_____ %	2000 nos. per month
4	TD2A06H08	Hex Bolt (as per ALIMCO drg.)	4000 nos.		_____ %	_____ %	1000 nos. per month
5	TD2A06V00	Belt Assy. (as per ALIMCO drg.)	2500 nos.		_____ %	_____ %	625 nos. per month
6	TD2A06G03	Pad Footrest (as per ALIMCO drg.)	2000 nos.		_____ %	_____ %	500 nos. per month
7	TD2A06HA4	Bush Swivel (as per ALIMCO drg.)	4000 nos.		_____ %	_____ %	1000 nos. per month
8	TD2A07005	Label – Symbol of Accessibility (as per ALIMCO drg.)	8000 nos.		_____ %	_____ %	2000 nos. per month
F.O.R. :- _____							

Note:

1. If the rate quoted is inclusive of GST, Freight and Packing & Forwarding etc. then offer shall be summarily rejected without any further clarification/ notice.
2. The rates should be quoted as per above format, if the offers/ quoted rates are not in above specified format same may not consider for further processing without any further information.
3. The Tenderer/ Bidder needs to submit Annexure 'A' & Annexure 'B' alongwith the offer.

Seal & Signature

Party Name

TENDER ACCEPTANCE LETTER

(To be given on Tenderer/ Bidder's Letter Head)

Date:

To,
In-charge/ Materials Department,
APC-ALIMCO,
Plot No. 40 & 106, Industrial Area, Richhai,
Jabalpur - 482010

Sub: Acceptance of Terms & Conditions of Tender.

Tender Reference No: _____

Name/ Code of Tendered items/ Work:- _____

Dear Sir,

1. I/ We hereby certify that I/ we have read the entire terms and conditions of the tender documents from Page No. _____ to _____ [including all documents like Annexure(s), Schedule(s), specification and drawing, etc.], which form part of the contract agreement and I/ we shall abide hereby by the terms/ conditions /clauses contained therein.
2. The corrigendum(s) issued from time to time by your department/ organization too have also been taken into consideration, while submitting this acceptance letter.
3. I/ We hereby unconditionally accept the tender conditions of above mentioned tender document(s)/ corrigendum(s) in its totality/ entirety.
4. I/ We do hereby declare that our Firm has not been blacklisted/ debarred/ terminated/ banned by any Govt. Department/ Public sector undertaking.
5. I/ We certify that all information furnished by our Firm is true & correct and in the event that the information is found to be incorrect/ untrue or found violated, then your department/ organization shall without giving any notice or reason therefore or summarily reject the bid or terminate the contract, without prejudice to any other rights or remedy including the forfeiture of the full said earnest money deposit absolutely.

Yours Faithfully,

(Signature of the Party/ Bidder, with Official Seal)

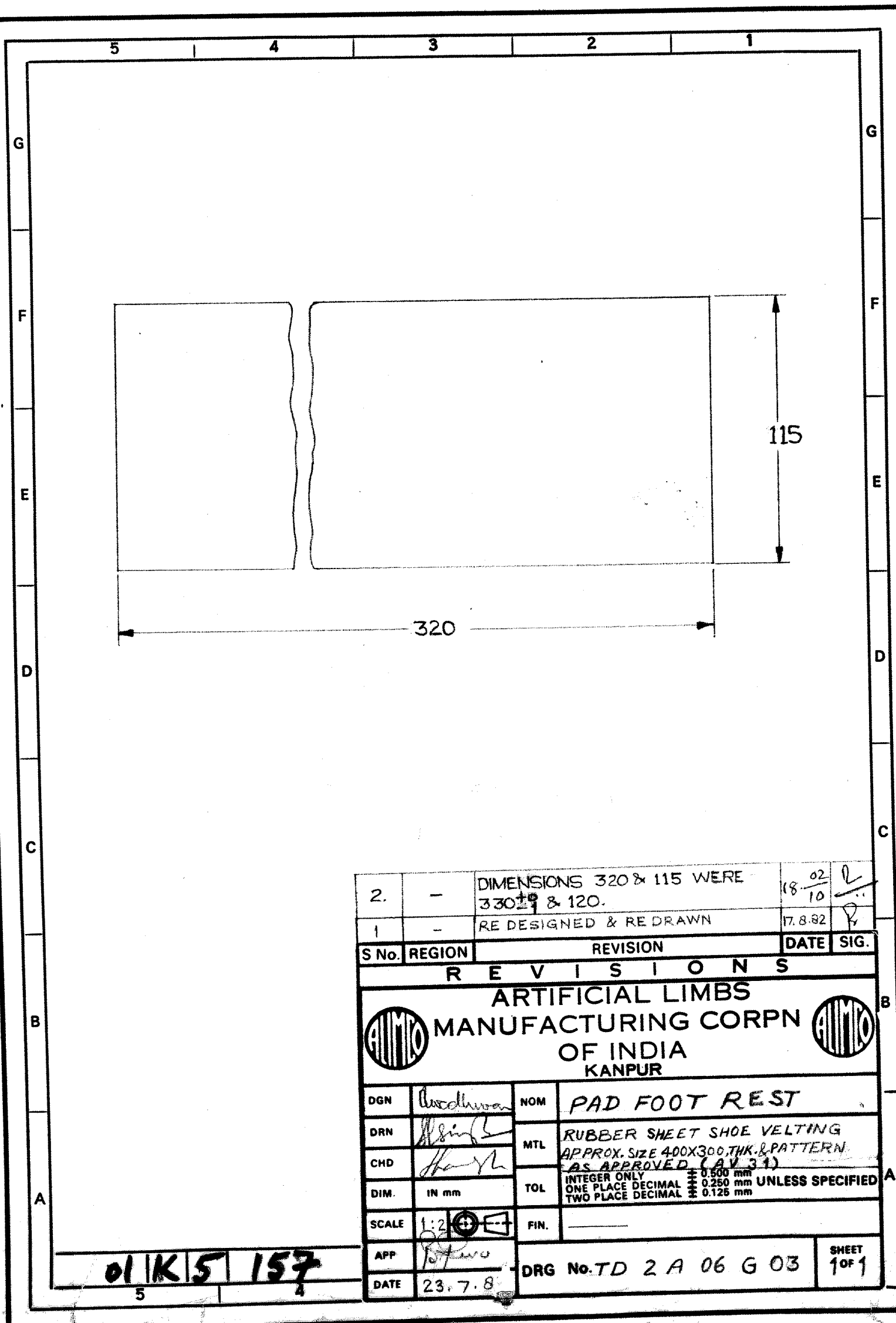

2.	-	DIMENSIONS 320 & 115 WERE 330 & 120.	18/02/10	<i>[Signature]</i>
1	-	RE DESIGNED & RE DRAWN	17.8.82	<i>[Signature]</i>
S No.	REGION	REVISION	DATE	SIG.
R E V I S I O N S				
ARTIFICIAL LIMBS MANUFACTURING CORPN OF INDIA KANPUR				
DGN	<i>Aradhwan</i>	NOM	PAD FOOT REST	
DRN	<i>[Signature]</i>	MTL	RUBBER SHEET SHOE VELTING APPROX. SIZE 400X300 THK. & PATTERN AS APPROVED (AV 31)	
CHD	<i>[Signature]</i>	TOL	INTEGER ONLY ± 0.500 mm ONE PLACE DECIMAL ± 0.250 mm TWO PLACE DECIMAL ± 0.125 mm	
DIM.	IN mm	FIN.		
SCALE	1:2	FIN.		
APP	<i>[Signature]</i>	DRG No.	TD 2 A 06 G 03	
DATE	23.7.8	SHEET	1 OF 1	

01 | K | 5 | 157

5 4 3 2 1

G

G

F

F

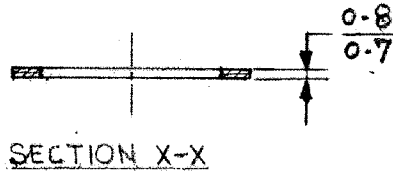
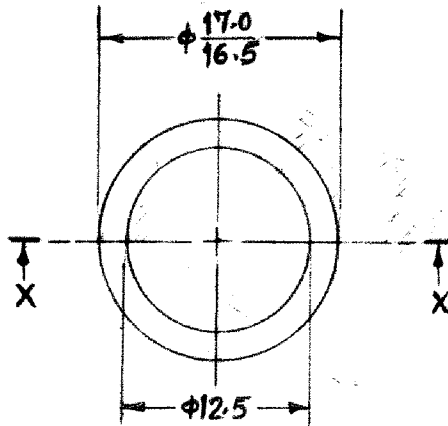

E

E

D

D

C

C

NOTE:-

1. REMOVE SHARP EDGES.

B

B

1	E-2	THK 0.8/0.7 WAS 0.6/0.5	5.9.98	AW
S No.	REGION	REVISION	DATE	SIG.

R E V I S I O N S



ARTIFICIAL LIMBS
MANUFACTURING CORPN
OF INDIA
KANPUR



DGN	<i>Manubhai</i>	NOM	WASHER NYLON
DRN	<i>Krishna</i>	MTL	GRANULES POLYAMIDE (NYLON) IS: 7078 (AW 90)
CHD	<i>Mohant</i>	TOL	INTEGER ONLY ± 0.500 mm ONE PLACE DECIMAL ± 0.250 mm TWO PLACE DECIMAL ± 0.125 mm UNLESS SPECIFIED
DIM.	IN mm	FIN.	MOULDED
SCALE	2:1	APP	<i>Pedder</i>
APP	<i>Pedder</i>	DATE	11.4.81
DATE	11.4.81	DRG No.	TD 2 A 06 H 05
			SHEET 1 OF 1

01 | K | 8 | 014

5

4

A

A

5

4

3

2

1

G

F

E

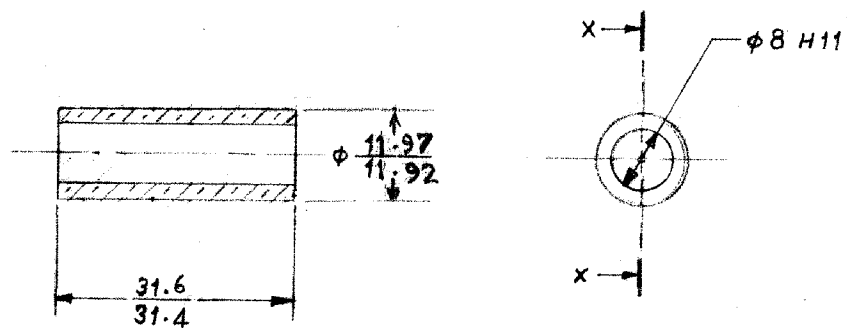

SECTION - XX

MTL:—

SINTERED IRON AS PER IS: 3980,

Gd-2 (IRON BASE) CLASS-B1.

DENSITY - 6.2 - 6.6 g/cm³ (H).

COMPOSITION:—

COPPER ———— 1.5-3.5%.

CARBON ———— 0.25% MAX.

OTHER ELEMENTS ———— 2% MAX.

IRON ———— BALANCE.

INTERCONNECTED-

POROSITY% MIN ———— 12% MIN.

S.No.	REGION	REVISION	DATE	SIG.
4	-	MTL - SINTERED IRON WAS SINTERED BRONZE OR AR20	20-4-10	
3	F-3	SK ϕ 11.97 WAS 14.97	14.5.91	SK
2	D-5	MTL-SINTERED BRONZE ADDED	8.8.89	Pelle
1	A-2 E-3	MTL. BRASS WAS NYLON & ϕ 14.9/14.85 WAS ϕ 14.92/14.88	18.1.89	Pelle

R E V I S I O N S



ARTIFICIAL LIMBS
MANUFACTURING CORPN.
OF INDIA
KANPUR



DGN.	<i>Woodin</i>	NOM.	BEARING SLEEVE
DRN.	<i>SK</i>	MTL.	INDICATED
CHD.	<i>Handwritten</i>	TOL.	INTEGER ONLY 20.500 mm ONE PLACE DECIMAL 20.250 mm UNLESS SPECIFIED TWO PLACE DECIMAL 20.126 mm
DIM.	IN mm	FIN.	
SCALE	1:1		
APP.	<i>Handwritten</i>		
DATE	28.1.82	DRG.NO. TD 2 A 06 H 06	SHEET 1 OF 1

01 K 8 0 8 9

5

4

5

4

3

2

1

G

F

E

D

C

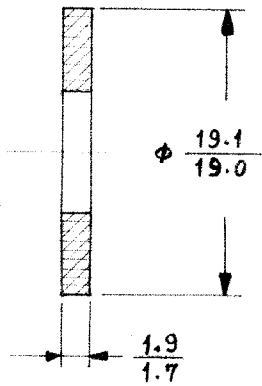

B

A

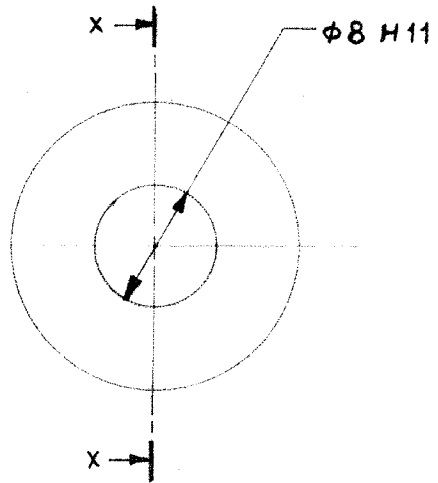

SECTION-XX



S.No.	REGION	REVISION	DATE	SIG.
R E V I S I O N S				
 ARTIFICIAL LIMBS MANUFACTURING CORPN. OF INDIA  KANPUR				
DGN.	<i>[Signature]</i>	NOM.	WASHER I.D. 8	
DRN.	<i>[Signature]</i>	MTL.	GRANULES POLYAMIDE (NYLON) IS: 7078 (AW 90)	
CHD.	<i>[Signature]</i>	TOL.	INTEGER ONLY ± 0.500 mm ONE PLACE DECIMAL ± 0.250 mm TWO PLACE DECIMAL ± 0.125 mm UNLESS SPECIFIED	
DIM.	IN mm	FIN.	MOULDED	
SCALE	2:1 			
APP.	<i>[Signature]</i>	DRG. NO. TD 2 A 06 H 07		SHEET OF 1
DATE	28.1.82			

01 K 8 090

5

4

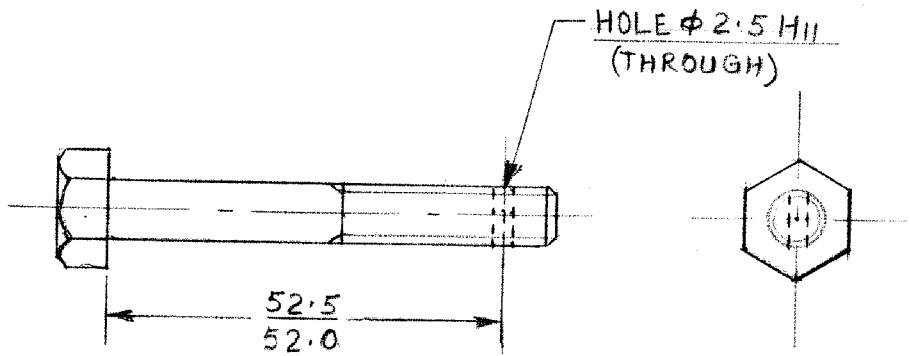

S No.	REGION	REVISION	DATE	SIG.
R E V I S I O N S				
ARTIFICIAL LIMBS MANUFACTURING CORPN OF INDIA KANPUR				
DGN	<i>Shashi</i>	NOM	HEX. BOLT	
DRN	<i>Shashi</i>	MTL	HEX. BOLT M8X60, IS:1363 (BB 14)	
CHD	<i>Bh</i>	TOL	INTEGER ONLY ± 0.500 mm ONE PLACE DECIMAL ± 0.250 mm TWO PLACE DECIMAL ± 0.125 mm UNLESS SPECIFIED	
DIM.	IN mm	FIN.	ZINC PLATED THK. 6 TO 8 MICRONS.	
SCALE	1:1	APP	DRG No. TD 2 A 06 H 08	
DATE	14.9.91		SHEET 1 OF 1	

01 K8 267

5

4

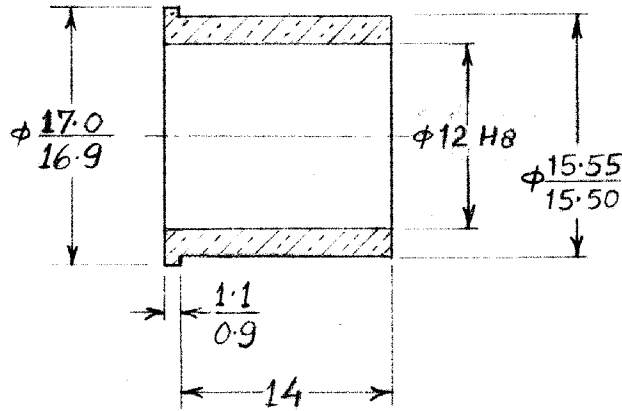

MTL:—

SINTERED IRON AS PER IS: 3980,

Gd-2 (IRON BASE), CLASS -B1.

DENSITY - 6.2 - 6.6g/Cm³ (H).

COMPOSITION:—

COPPER — — — — — 1.5 - 3.5%

CARBON — — — — — 0.25% MAX.

OTHER ELEMENTS — — 2% MAX.

IRON — — — — — BALANCE.

INTERCONNECTED -

POROSITY % MIN — — — — 12% MIN.

5	-	MTL:- SINTERED IRON WAS SINTERED BRONZE OR AR 22	20.4.10	
4	F-2	φ15.55/15.50 WAS 16.05/16.00	3.8.2001	RSK
3	F-2	φ12 H8 WAS φ12.10/12.05	20.10.89	
2	D-5	MTL- SINTERED BRONZE ADDED	8.8.89	Full
1	A-2 E-2	MTL. BRASS WAS NYLON, — φ12.10/12.05 WAS φ12.20/12.15	18.1.89	Full

S No.	REGION	REVISION	DATE	SIG.
-------	--------	----------	------	------

R E V I S I O N S



**ARTIFICIAL LIMBS
MANUFACTURING CORPN
OF INDIA
KANPUR**



DGN.	<i>Woodh...</i>	NOM	BUSH SWIVEL
DRN	<i>Bh...</i>	MTL	INDICATED
CHD	<i>Harsh...</i>	TOL.	INTEGER ONLY ± 0.500 mm ONE PLACE DECIMAL ± 0.250 mm TWO PLACE DECIMAL ± 0.125 mm UNLESS SPECIFIED
DIM.	IN mm	FIN.	
SCALE	2:1		
APP	<i>B...</i>	DRG No.	TD 2 A 06 H A 4
DATE	21.5.82	SHEET	OF 1

01 | K | 5 | 151

5

4

ITEM NO.	DRG. NO.	NOMENCLATURE	NO.OFF	REMARK
1	TD 2 A 06 V 01	BELT	1	
2	TD 2 A 06 V 02	BUCKLE	1	

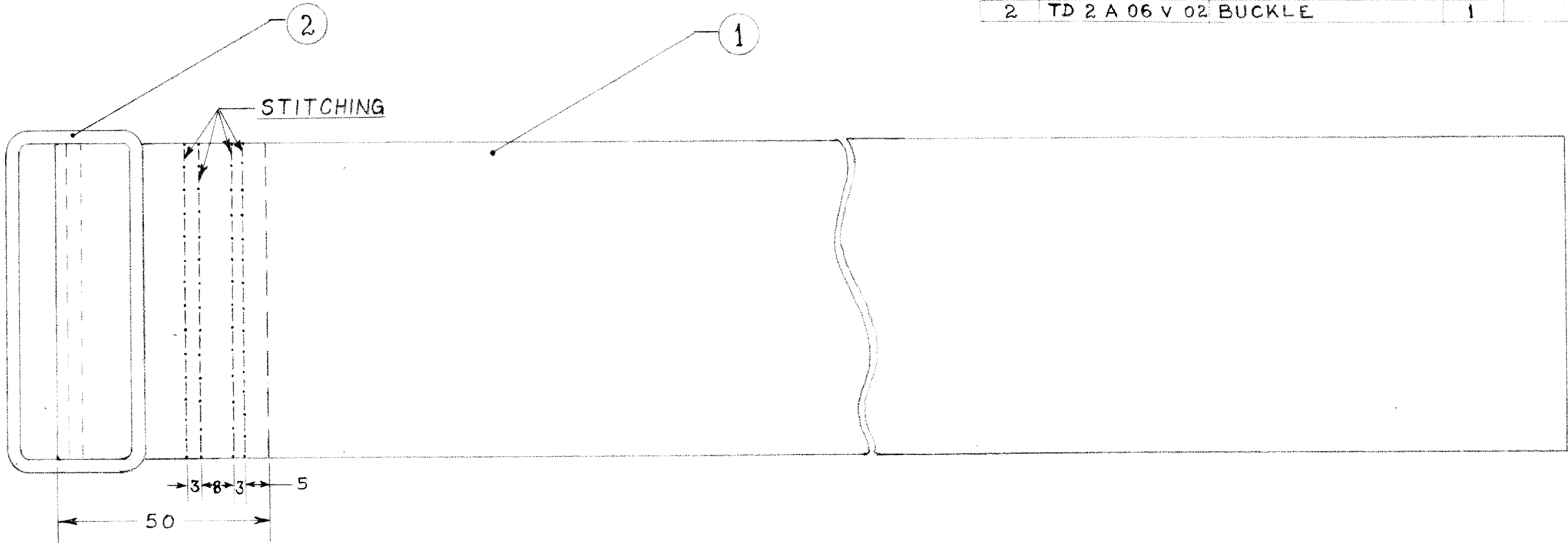

NOTE:-

1. USE BLACK NYLON THREAD 210/6 (COATS NO. 2, 4) FOR STITCHING.
2. STITCHING PITCH 3 TO 5 mm.

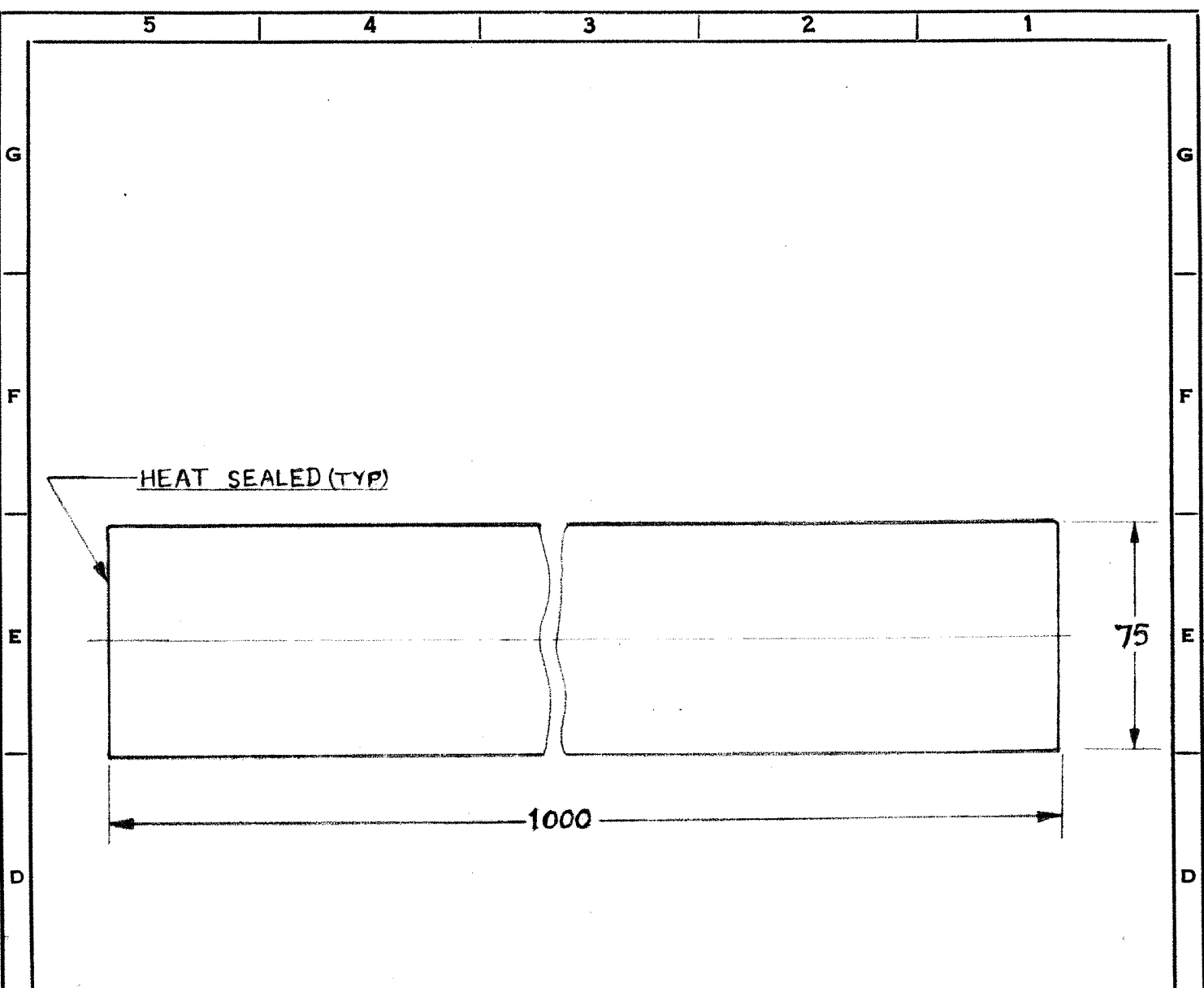

S No.	REGION	REVISION	DATE	SIG.
REVISIONS				
ARTIFICIAL LIMBS MANUFACTURING CORPN OF INDIA KANPUR				
DGN	<i>K. S. Swivedi</i>	NOM	BELT ASSY.	
DRN	<i>K. S. Swivedi</i>	MTL		
CHKD	<i>[Signature]</i>	TOL	INTEGER ONLY ± 0.500 mm ONE PLACE DECIMAL ± 0.250 mm TWO PLACE DECIMAL ± 0.125 mm UNLESS SPECIFIED	
DIM.	IN mm	FIN.		
SCALE	1:1			
APP	<i>[Signature]</i>	DRG No.	TD 2 A 06 V. 00	SHEET 1 OF 1
DATE	20-9-06			

01 G 2 274



MTL: — AY 54

PP/NYLON WEBBING (BLACK COLOUR)
 75 mm (3") WIDE, THICK 2.5/1.5 mm,
 WEIGHT - 95/55 gms/mtr,
 BREAKING LOAD > 250 kg/50 mm

S No.	REGION	REVISION	DATE	SIG.
R E V I S I O N S				
 ARTIFICIAL LIMBS MANUFACTURING CORPN OF INDIA KANPUR 				
DGN	<i>Parivesh</i>	NOM	BELT	
DRN	<i>Parivesh</i>	MTL	INDICATED	
CHD	<i>Shirish</i>	TOL	INTEGER ONLY ± 0.500 mm ONE PLACE DECIMAL ± 0.250 mm TWO PLACE DECIMAL ± 0.125 mm	
DIM.	IN mm	FIN.		
SCALE	1:2 			
APP	<i>V. S.</i>	DRG No. TD 2A 06V 01		SHEET 1 OF 1
DATE	20.9.06			

01 | K | 8 | 345

5 | 4

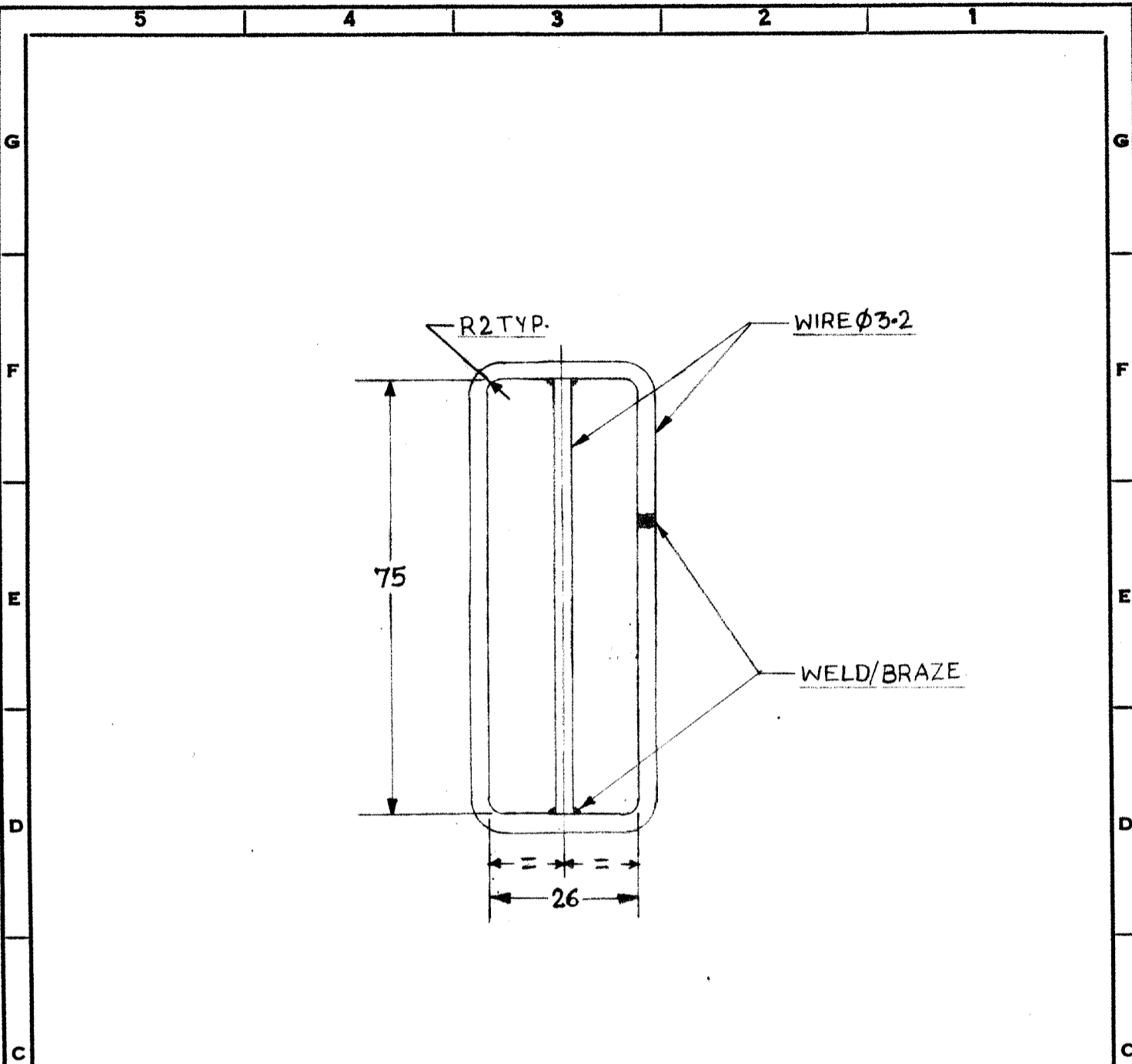

NOTE:

1. DRESS ALL WELDED JOINTS & FINISH SMOOTH.
2. READYMADE AVAILABLE IS ACCEPTABLE.

S No.	REGION	REVISION	DATE	SIG.
REVISIONS				
ARTIFICIAL LIMBS				
MANUFACTURING CORPN				
OF INDIA				
KANPUR				
DGN	<i>K. S. ...</i>	NOM	BUCKLE	
DRN	<i>Parinash</i>	MTL	WIRE MS BRIGHT DRAWN ϕ 3.2mm IS:280 (AC 25)	
CHD	<i>...</i>	TOL	INTEGER ONLY \pm 0.500 mm ONE PLACE DECIMAL \pm 0.250 mm TWO PLACE DECIMAL \pm 0.125 mm UNLESS SPECIFIED	
DIM.	IN mm	FIN.	Ni. Cr. PLATED Gd. 2, IS:1068	
SCALE	1:1	APP	<i>J. S.</i>	
DATE	20.9.06	DRG No.	TD 2A 06 V 02	
				SHEET
				1 OF 1

01 | K | 8 | 346

5

4

3

2

1

G

G

F

F

E

E

D

D

C

C

B

B

A

A

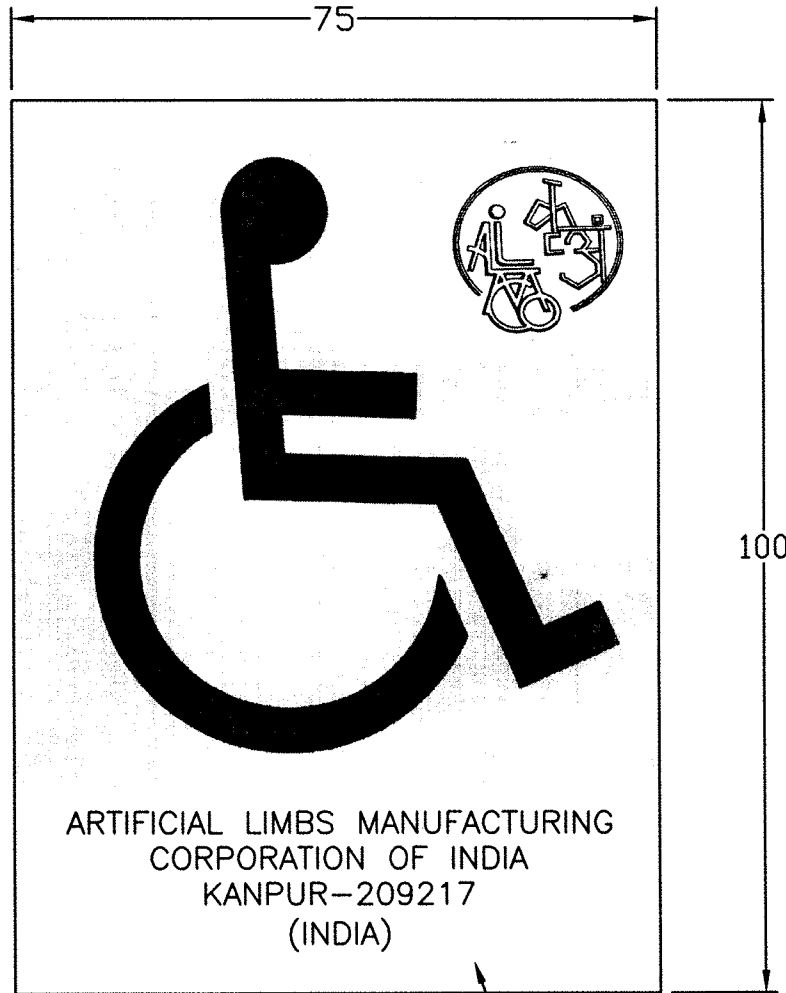

BACKGROUND BLACK

NOTE:--

1. SYMBOL'S PROPORTIONS AS SHOWN.
2. LABEL TO BE PROVIDED GLUED ON REVERSE WITH PAPER BACKING.

TOLERANCE:--

DEVIATION FOR NON TOLERANCED DIMENSIONS
(ISI:2102 MEDIUM)

DIAMETER & LENGTHS BETWEEN	TOLERANCE	LENGTH IN MM OF SHORTER SIDE OF ANGLE UPTO & INCL.	TOLERANCE
0.5 up to 6	±0.1	Up to 10	±1°00'
Over 6 up to 30	±0.2	Over 10 upto 50	±0°30'
Over 30 up to 120	±0.3	Over 50 upto 120	±0°20'
Over 120 up to 315	±0.5	Over 120 upto 400	±0°10'
Over 315 up to 1000	±0.8		
Over 1000 up to 2000	±1.2		
Over 2000 up to 4000	±2.0		

MACHINING FINISH IN MICRONS
▽ 8 - 25 ▽ 1.6 - 8 ▽▽ 0.025 - 1.6 ▽▽▽ <0.025

THIS DRAWINGS AND SPECIFICATION ARE THE PROPERTY OF ALIMCO AND SHALL NOT BE REPRODUCED OR COPIED WITHOUT PRIOR PERMISSION.

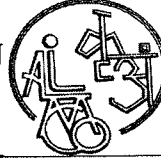
4	—	ALIMCO LOGO MODIFIED	28.02.17
SNNo.	REGION	REVISION	DATE SIGN
R E V I S I O N S			
 ARTIFICIAL LIMBS MANUFACTURING CORPORATION OF INDIA KANPUR 			
DGN	<i>Chavla</i>	NOM	LABEL-SYMBOL OF ACCESSIBILITY
DRN	<i>Chavla</i>	MTL	ALUMINIUM FOIL THK 60 TO 70 MICRONS
CHD	<i>Chavla</i>	HEAT TREATMENT	—
DIM	IN mm	SURFACE TREATMENT	—
SCALE	NTS		
APP	Sd/DD1		
DATE	12.12.1978	DRG No:- TD 2 A 07 0 05	SHEET 10F1

5

4