

INVITATION TO QUOTE



IS/ISO 9001:2015

ALIMCO - AUXILIARY PRODUCTION CENTRE, ARTIFICIAL LIMBS MANUFACTURING CORPORATION OF INDIA

(A GOVT. OF INDIA UNDERTAKING "MINIRATNA" COMPANY)

Plot No. 40 & 106, Industrial Area, Richhai, Jabalpur (M.P.) – 482010

Telephone: 0761-2334717, 2334724, Web: www.alimco.in

E-mail: aapc_jabalpur@alimco.in



CIN: U85110UP1972NPL003646

//

GSTIN: 23AABCA8899F1ZG

M/s

Enquiry No.	:	LT-16/JBP/AX
Dated	:	17/05/2019
Due Date	:	08/06/2019

Dear Sir,

Sealed quotation are invited in rate format as specify in "Annexure-A" for the supply of the following stores strictly as per our specification /drawings (where applicable) for the quantities and the staggered Delivery Schedule as indicated and as per the terms & conditions mentioned overleaf, to reach us by 14:00 hrs. on or before the due date:-

ALIMCO Code No.	Total Qty./Unit
01	AS PER ANNEXURE 'A'
Description of Stores	
Delivery Schedule	Qty./ Date
Note (A):-	<ol style="list-style-type: none">The basic price/ rate, GST (If applicable), Packing & Forwarding charges and Freight charges must be mentioned separately & specifically. The offer quoted Inclusive of GST Taxes, Packing & Forwarding Charges and freight charges may not consider for further processing.Kindly mention GSTIN in your offer.Maximum period required to commence supplies which may normally be not exceeding 30 days from the date of placement of Purchase Order.This is fixed price tender. Any request for rate revision till currency of P.O. shall not be considered.Jigs, Fixture & Dies for manufacture of the tendered items required, if any, is to be developed by the party at their own cost.The tentative quantities likely to be covered by Purchase Order are indicated above. The material would be required to be supplied on staggered delivery schedules to be indicated in Purchase Order or as required by the Corporation.The total requirement of the above material may vary substantially up or down as per requirement of the Corporation & successful tenderer will be required to arrange the supplies accordingly.The tentative monthly requirement will be approx. 1/12th of the quantity indicated above subject to be change by the corporation which may vary substantially up or down as per requirement of the corporation.

For: ALIMCO-Auxiliary Production Centre, Jabalpur

Material Management Deptt.

Note (B):-

(i) Kindly mention the Enquiry No. and Due date on Envelop.

(ii) In case of any such requirement the corporation will be entitled to place "Repeat Order" on the same rate, terms & conditions subject to mutual consent.

(iii) The corporation has right to amend the Tender/ Purchase Order quantity (enhanced/ reduced) in case of change/ amendment in the Production schedule during currency of Purchase Order to meet out the Corporation's target/ commitments as per customer's/ marketing department requirement.

(iv) Tenderer/ Suppliers are requested to quote/ submit their offer FOR: "APC-ALIMCO, JABALPUR".

TERMS AND CONDITIONS

1. **Submission of Tenders** – (a) Tenders shall be sent in a sealed envelope super scribing the Enquiry No. & due date. (b) Tender shall be addressed to "Materials Department, ALIMCO-Auxiliary Production Centre, Plot No. 40 & 106, Industrial Area, Richhai, Jabalpur – 482010 (M.P.)". (c) The Tenderers may at their discretion send the Tenders by Registered/Speed Post Acknowledgement Due, but postal and transit delay shall not be necessarily considered in reckoning the tenders for our consideration.
2. **Validity of Tenders** – (a) The tenders shall remain open for acceptance for a minimum period of 90 days from the date of opening of tenders or till such period upto which the extension of validity is agreed to mutually. This may be please be stipulated clearly in the quotation. (b) If notified within this period that the tender has been accepted the tenderer shall be bound by the terms of the offer along with the terms that have been agreed to mutually. (c) All tenders without `proper specification, samples, drawings and Testing certificates, where required, are liable to be rejected. It shall be in interest of tenderer that are complete offer is made for our consideration.
3. **Details of offer** – (a) **The quoted rates shall be Quoted FOR delivery at our Jabalpur Factory the following data shall be invariable furnished :- (i) Basic firm price of stores; (ii) GST, if any applicable; (iii) packing and forwarding charges, if any; (iv) Freight Charges. (b) In the case of quotations from local parties, the following rates shall be indicated specifically:- (i) Rate for delivery at the APC-ALIMCO, Jabalpur Factory, (ii) Rate for delivery Ex-shop/ Ex-Go down JABALPUR.**
4. **Taxes:** – The GST applicable shall clearly be indicated in percentage. Our GSTIN is 23AABCA8899F1ZG.
5. **DGS&D Rate Contract** – (a) Wherever the stores/equipments have been covered by the DGS&D rate contracts, the price shall conform to the same. A copy of current rate contract shall be enclosed for our ready reference. (b) Wherever the stores have not been covered under the DGS&D contract but under the rate contract of any State Stores Purchase Organization/Directorate of Industries, the price shall conform to the same. A copy of the current rate contract shall be enclosed for our ready reference. (c) All SSI units / Micro & Small Enterprises (MSE) will be issued Tender Documents free of cost & Exemption to submit Earnest Money Deposit (EMD) on submission of valid Udyog Aadhar Memorandum (UAM) against Tender for the items/nature of business/ type of services specified therein in the UAM.
6. **Quantity Discounts** – In order to submit the most competitive offer, the tenderer may indicate the quantity discount on a "slab basis" applicable on the price. However, the buyer reserves the right to accept the quantity discounts. The quantities indicated in this enquiry are liable to revision either upwards or downwards.
7. **Delivery** –
 - (a) In their own interest, tenderers are advised to quote for the earliest possible delivery. Where Ex-stock delivery's quoted stock shall be held by the tenderer during the validity period of quotation.
 - (b) The delivery of the stores/equipment shall be made strictly as stipulated. Failure to supply within this period make the tenderers liable on to an unconditional penalty of $\frac{1}{2}\%$ of the price of the goods in arrears per week subject to a maximum limit of **10%** of value of the goods in arrears.
 - (c) The supply of all items shall be completed satisfactorily within the stipulated delivery period of the order failing which ALIMCO reserves the right to obtain / purchase stores from other sources at your sole risk, responsibility and cost. If any higher price has to be paid above the contracted price, the loss which may occur on this account, shall be recovered from the tenderer.
 - (d) **The supplies shall be made in proper packing (in countable quantity) to avoid any damage/loss/pilferage in transit & storage.**
8. **Terms & Payment** – (a) Ours is a Government of India Undertaking registered under "Section 8" of the Indian Companies Act, 2013. As such the following terms of payment are stipulated:-
 - i) **100% payment within 30 days after receipt and acceptance of the materials/stores/equipment without any damage/short supplies after the submission of bill, whichever is later will be made. However, the GST portion will be payable only after submission of proof/ self-certified copy of GST return filed online by the tenderer clearly (duly highlighted) showing invoices/ bill number and amount submitted to ALIMCO.**
 - ii) **Acceptance of Payment Terms other than standard Payment Terms of within 30 days,** is at the discretion of management and in that case 1% of total landed cost will be considered additional while preparing Comparative Statement of Quotations (CSQ). However, Purchase Order will be placed at quoted rates.
 - iii) **Payment in Advance terms is not acceptable.**
9. **Important instructions** – (a) Where the item offered is not as per our specified make/size, the reason for not offering the same (e.g. not in ready stock etc.) shall be clearly indicated. (b) Please quote for delivery at our factory site. However, Packing and Forwarding, Freight Charges wherever applicable shall be given clearly in % in format at Annexure-'A'.
10. **Opening of Tenders** – The tenders shall be **opened at 15:00 hours on due date** in presence of representatives of tenderers who may like to be present.
11. ALIMCO reserves the right to split up the total order quantity to more than 01 bidder to avoid stock out situation wherever necessary. In case of split up to 3 parties, 60% qty. may be placed on L-1 and 20% each on L-2 & L-3 provided they agree to match the rate with L-1 and in case of split up 02 parties 60% of the Qty. may be placed on L-1 and 40% on L-2 provided L-2 agree to match the rate with L-1.
12. **Offers for supplies other than FOR APC-ALIMCO, Jabalpur/ Ex-shop, Jabalpur/ Ex-works, Jabalpur/ FOR Jabalpur will be summarily rejected. However, offers for other than FOR APC-ALIMCO, Jabalpur but for Ex-shop, Jabalpur/ Ex-works, Jabalpur/ FOR Jabalpur shall be loaded by 2% of basic cost for working out the landed cost & comparison purposes in CSQ. However Purchase Order will be placed at quoted rates terms & conditions. But, the successful tender has to provide/ offer duly packed material.**
13. Inspection of supplies will be carried out at the premises only of APC-ALIMCO, JABALPUR, as the case may be, which shall be final & binding on tenderer.
14. **The other terms & conditions of corporation's Purchase Policy shall be applicable.**
15. If any dispute/ question or controversy arises, the settlement of which is not herein specially provided in this Tender/ Order/ Contract, the matter in dispute shall be referred to the arbitration of Chairman and Managing Director of ALIMCO or his nominee and decision of Chairman and Managing Director or his nominee shall be final and binding on both the parties. The provision of INDIAN ARBITRATION & CONCILLATION ACT, 1956 as amended from time to time shall apply to such arbitration proceedings. Arbitration proceeding shall be held at Kanpur only and Kanpur Nagar Court will have jurisdiction in the matter.

Tender No. LT-16/JBP/AX

Sl. No.	ALIMCO Code No.	Description of Stores/ Nomenclature (AS PER ALIMCO DRG.)	Qty./ Unit (in nos)	Basic Price ₹ (Per Unit)	Freight & packing/ forwarding etc. (in % only)	GST rates in terms of Percentage (%), if applicable	Tentative delivery schedule
1	TD2A02D01	BRAKE LEVER	15000		_____ %	_____ %	Approx. 25% per month
2	TD2A02D02	BRAKE SHOE	10000		_____ %	_____ %	Approx. 25% per month
3	TD2A02D04	STATIONARY LINK	15000		_____ %	_____ %	Approx. 25% per month
4	TD2A06JC2	NUT	65000		_____ %	_____ %	Approx. 25% per month
5	TD2A07A19	STUD	40000		_____ %	_____ %	Approx. 25% per month
6	TD2A07A25	BRACKET	20000		_____ %	_____ %	Approx. 25% per month
7	TD2A06JB2	BRACKET	40000		_____ %	_____ %	Approx. 25% per month
8	TD2A07A11	BUSH AXLE	5000		_____ %	_____ %	Approx. 25% per month
F.O.R. :- _____							

Note:

1. If the rate quoted is inclusive of GST, Freight and Packing & Forwarding etc. then offer shall be summarily rejected without any further clarification/ notice.
2. The rates should be quoted as per above format, if the offers/ quoted rates are not in above specified format same may not consider for further processing without any further information.
3. The Tenderer/ Bidder needs to submit Annexure 'A' & Annexure 'B' alongwith the offer.

Seal & Signature

Party Name

Date:

TENDER ACCEPTANCE LETTER

(To be given on Tenderer/ Bidder's Letter Head)

Date:

To,
In-charge/ Materials Department,
APC-ALIMCO,
Plot No. 40 & 106, Industrial Area, Richhai,
Jabalpur - 482010

Sub: Acceptance of Terms & Conditions of Tender.

Tender Reference No: _____

Name/ Code of Tendered items/ Work:- _____

Dear Sir,

1. I/ We hereby certify that I/ we have read the entire terms and conditions of the tender documents from Page No. _____ to _____ [including all documents like Annexure(s), Schedule(s), specification and drawing, etc.], which form part of the contract agreement and I/ we shall abide hereby by the terms/ conditions /clauses contained therein.
2. The corrigendum(s) issued from time to time by your department/ organization too have also been taken into consideration, while submitting this acceptance letter.
3. I/ We hereby unconditionally accept the tender conditions of above mentioned tender document(s)/ corrigendum(s) in its totality/ entirety.
4. I/ We do hereby declare that our Firm has not been blacklisted/ debarred/ terminated/ banned by any Govt. Department/ Public sector undertaking.
5. I/ We certify that all information furnished by our Firm is true & correct and in the event that the information is found to be incorrect/ untrue or found violated, then your department/ organization shall without giving any notice or reason therefore or summarily reject the bid or terminate the contract, without prejudice to any other rights or remedy including the forfeiture of the full said earnest money deposit absolutely.

Yours Faithfully,

(Signature of the Party/ Bidder, with Official Seal)

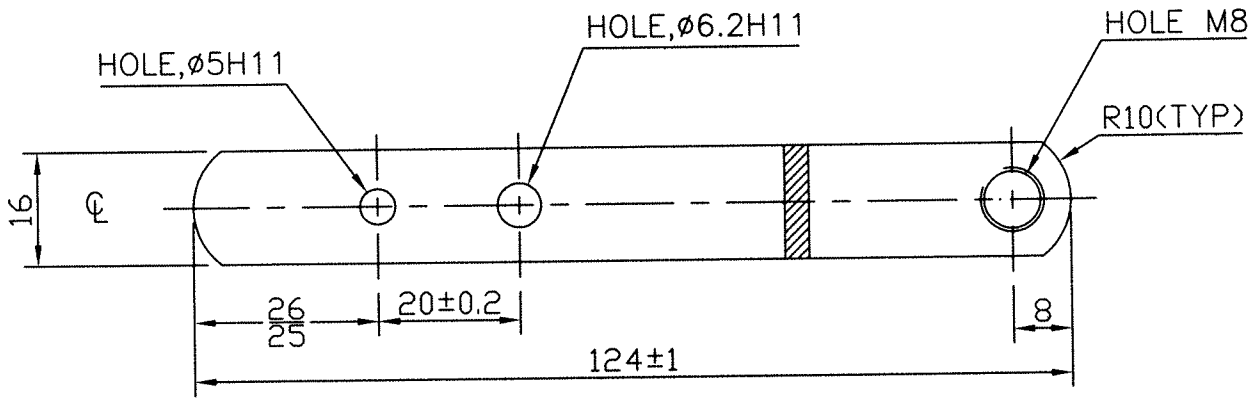



MTL:—

SHEET MS HRA Gd,'O',IS:1079,THK 3.15 (AA08)
OR
SHEET MS CRA Gd,'O',THK 3mm (AA28)

NOTE:—

1.REMOVE SHARP EDGES & CORNERS.

6	A-2	FINISH WAS STOVE ENAMEL PAINT & DRAWING REDRAWN	26 ⁰⁹ / ₁₃	<i>[Signature]</i>
SNNo.	REGION	REVISION	DATE	SIGN
R E V I S I O N S				
 ARTIFICIAL LIMBS MANUFACTURING CORPORATION OF INDIA KANPUR 				
DGN	<i>[Signature]</i>	NOM	BRAKE LEVER	
DRN	<i>[Signature]</i>	MTL	INDICATED	
CHD	<i>[Signature]</i>	TOL	INTEGER ONLY ±0.500 mm ONE PLACE DECIMAL ±0.250 mm TWO PLACE DECIMAL ±0.126 mm UNLESS SPECIFIED	
DIM	IN mm	FIN	Ni.Cr.PLATED Gd,2, IS:1068	
SCALE	NTS	APP	DRG No:— TD 2 A 02 D 01	
APP	<i>[Signature]</i>	DATE	10.05.1983	SHEET 10F1

01 K 5 190

5

4

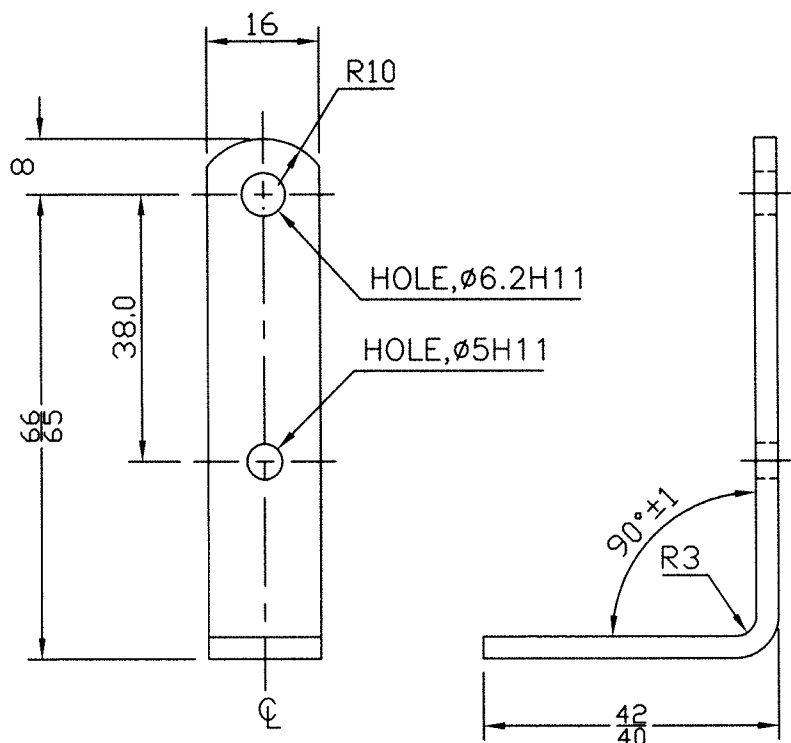



MTL:—

SHEET MS HRA Gd,'O',IS:1079,THK 3.15 (AA08)
OR
SHEET MS CRA Gd,'O',THK 3mm (AA28)

NOTE:—

1.REMOVE SHARP EDGES & CORNERS.

4		FINISH WAS STOVE ENAMEL PAINT & DRAWING REDRAWN	26/09/13	Ria
SNo.	REGION	REVISION	DATE	SIGN
R E V I S I O N S				
 ARTIFICIAL LIMBS MANUFACTURING CORPORATION OF INDIA KANPUR 				
DGN	<i>[Signature]</i>	NOM	BRAKE SHOE	
DRN	<i>[Signature]</i>	MTL	INDICATED	
CHD	<i>[Signature]</i>	TOL	INTEGER ONLY ±0.500 mm ONE PLACE DECIMAL ±0.250 mm TWO PLACE DECIMAL ±0.126 mm UNLESS SPECIFIED	
DIM	IN mm	FIN	Ni.Cr.PLATED Gd.2, IS:1068	
SCALE	NTS	APP	DRG No:—TD 2 A 02 D 02	
APP	<i>[Signature]</i>	DATE	10.05.1983	SHEET 10F1

01 K 5 191

5

4

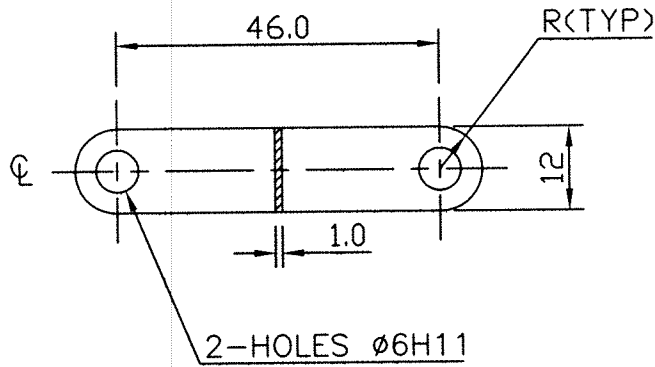

NOTE:-

1. REMOVE SHARP EDGES & CORNERS.

3	A-2	FINISH WAS STOVE ENAMEL PAINT & DRAWING REDRAWN	26/09/83	Rao
SNo.	REGION	REVISION	DATE	SIGN

REVISIONS



ARTIFICIAL LIMBS
MANUFACTURING CORPORATION
OF INDIA
KANPUR



DGN	<i>Chell</i>	NOM	STATIONARY LINK	
DRN	<i>Chell</i>	MTL	SHEET MS CRA Gd, '0', IS:513, THICK 1mm (AA 22)	
CHD	<i>Rao</i>	TOL	INTEGER ONLY ±0.500 mm ONE PLACE DECIMAL ±0.250 mm TWO PLACE DECIMAL ±0.126 mm	UNLESS SPECIFIED
DIM	IN mm	FIN	Ni.Cr.PLATED Gd.2, IS:1068	
SCALE	NTS	APP	<i>Sai/DDI</i>	DRG No:- TD 2 A 02 D 04
DATE	10.05.1983			SHEET 10F1

01	K	5	193
5		4	

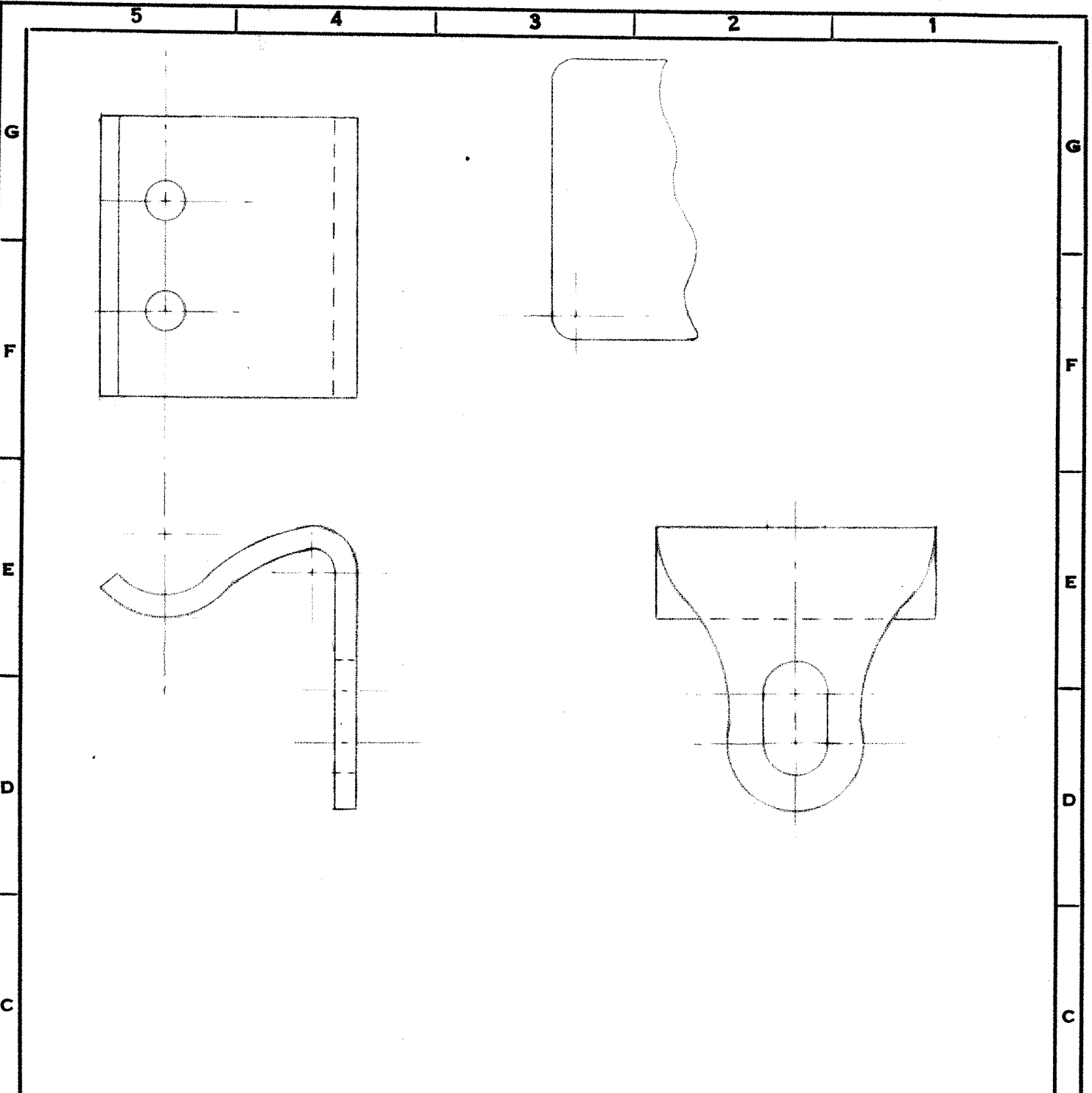

NOTE:-

1. FOR COMPONENT REFER -
DRG. NO. TD 2 A 06 J 98.

01 | K | 8 | 347

S No.	REGION	REVISION	DATE	SIG.
R E V I S I O N S				
ARTIFICIAL LIMBS MANUFACTURING CORPN OF INDIA KANPUR				
DGN	<i>K. S. Srinivas</i>	NOM	BRACKET	
DRN	<i>K. S. Srinivas</i>	MTL	SHEET MS COLD ROLLED ANNEALED	
CHD	<i>[Signature]</i>		G.d. '0', IS: 513, THICK 2mm (AA27)	
DIM.	IN mm	TOL	INTEGER ONLY ± 0.500 mm ONE PLACE DECIMAL ± 0.250 mm TWO PLACE DECIMAL ± 0.125 mm UNLESS SPECIFIED	
SCALE	2:1	FIN.	BRIGHT NICKEL PLATED	
APP	<i>[Signature]</i>	DRG No. TD 2 A 06 J B2		SHEET 1 OF 1
DATE	01-11-2006			

5 4 3 2 1

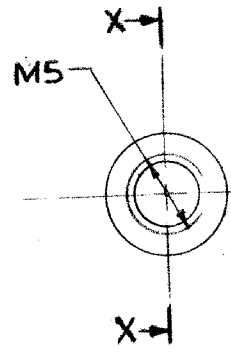
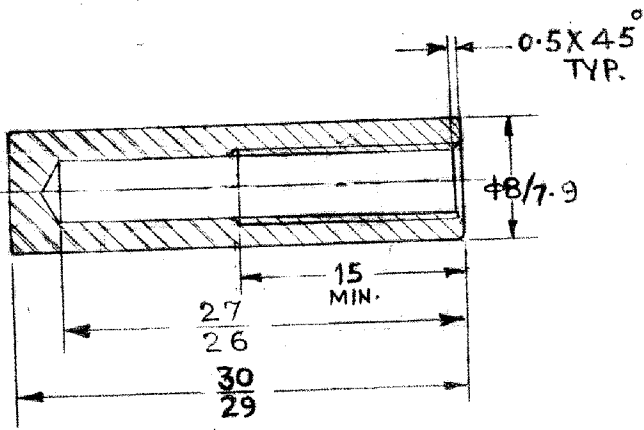

SECTION-X X

NOTE:-
 1. ROUND OFF SHARP EDGES & CORNERS
 2. WEIGHT - 8 gms (APPROX).

S No.	REGION	REVISION	DATE	SIG.
6	B-5	WEIGHT OF COMPONENT ADDED AT NOTE No.2	14.1.05	RK/2
5	F-4	DIM. 2.7/26 WAS 24/22	18.07.2000	RK/2
4	G-3	DIM. 0.5X45° ADDED	10.8.82	file
3	F-4	DIM. 24/22 ADDED	7.5.82	B
2	F-4	DIM. 15 MIN. ADDED	1.3.82	B
1	F-4	DIM. 30/29 WAS 25/24	2-1-82	B

ARTIFICIAL LIMBS MANUFACTURING CORPN OF INDIA KANPUR			
DGN	<i>Sharma</i>	NOM	NUT
DRN	<i>Sharma</i>	MTL	BAR MS COLD ROLLED BRIGHT ANNEALED φ8mm IS: 2515: 4855 (CODE NO. AB.56)
CHD	<i>Sharma</i>	TOL	INTEGER ONLY ± 0.500 mm ONE PLACE DECIMAL ± 0.250 mm TWO PLACE DECIMAL ± 0.125 mm UNLESS SPECIFIED
DIM.	IN mm	FIN.	
SCALE	2:1		
APP	<i>Sharma</i>	DRG No.	TD 2 A 06 J C 2
DATE	10.8.81	SHEET	1 OF 1

01 | K | 8 | 057
 5 4

5

4

3

2

1

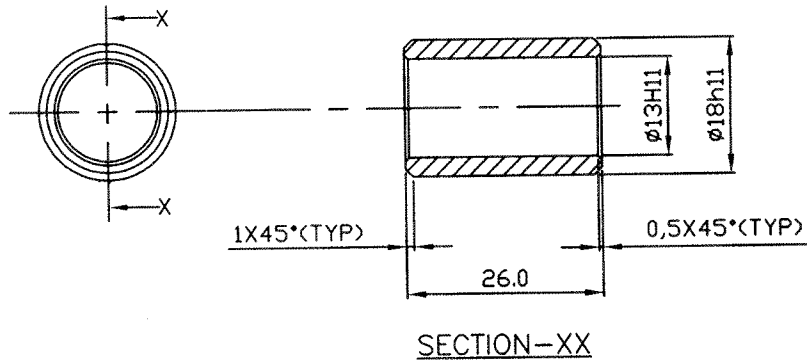

MTL:-

BAR MS CRBA ϕ 18mm
13 S 25 IS:4855 (AB 34)



OR

MS TUBE ERW C1,OD 18.00/17.90
WALL THICKNESS 2.6mm



NOTE:-

- 1.REMOVE SHARP EDGES & CORNERS
- 2.WEIGHT - 22gms(Approx)

7	—	ALTERNATE MTL ADDED & DRG REDRAWN	02.6.14	<i>[Signature]</i>
SNNo.	REGION	REVISION	DATE	SIGN
R E V I S I O N S				
 ARTIFICIAL LIMBS MANUFACTURING CORPORATION OF INDIA KANPUR 				
DGN	<i>[Signature]</i>	NOM	BUSH AXLE	
DRN	<i>[Signature]</i>	MTL	INDICATED	
CHD	<i>[Signature]</i>	TOL	INTEGER ONLY ± 0.500 mm ONE PLACE DECIMAL ± 0.250 mm TWO PLACE DECIMAL ± 0.126 mm <small>UNLESS SPECIFIED</small>	
DIM	IN mm	FIN	—	
SCALE	NTS 	APP	<i>[Signature]</i>	
01	K	5	022	DRG No:- TD 2 A 07 A 11
5	4	DATE	26.05.1978	SHEET 10F1

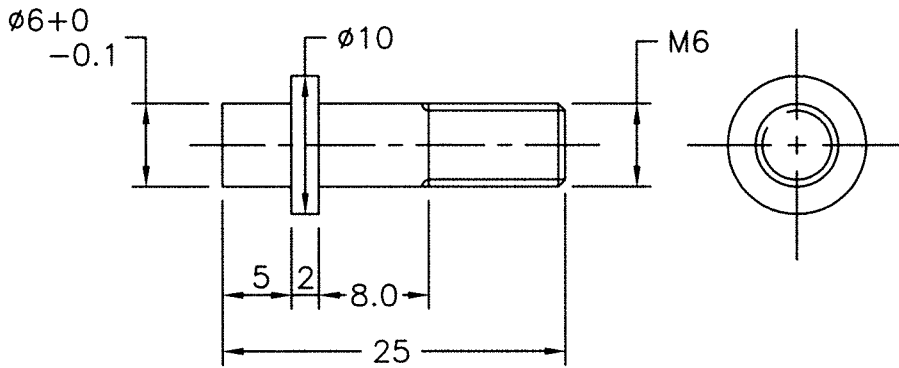

NOTE:---

1. REMOVE SHARP EDGES & CORNERS
2. WEIGHT - 6gms(APPROX)

5.	---	DRAWING REDRAWN	14.01.15	<i>Qa</i>
SNo.	REGION	REVISION	DATE	SIGN

REVISIONS



ARTIFICIAL LIMBS
MANUFACTURING CORPORATION
OF INDIA
KANPUR



DGN		NOM	STUD	
DRN	<i>Ashish</i>	MTL	BAR MS CRBA $\phi 10$ mm 13 S 25 IS:4855 (AB 51)	
CHD	<i>Qa</i>	TOL	INTEGER ONLY ± 0.500 mm ONE PLACE DECIMAL ± 0.250 mm TWO PLACE DECIMAL ± 0.126 mm	UNLESS SPECIFIED
DIM	IN mm	FIN	Ni. Cr. PLATED Gd'2' IS:1068	
SCALE	NTS			
APP	<i>Sa/DD1</i>			
DATE	26.05.1978		DRG No:--TD 2 A 07 A 19	SHEET 10F1

01	K	5	028
5			4

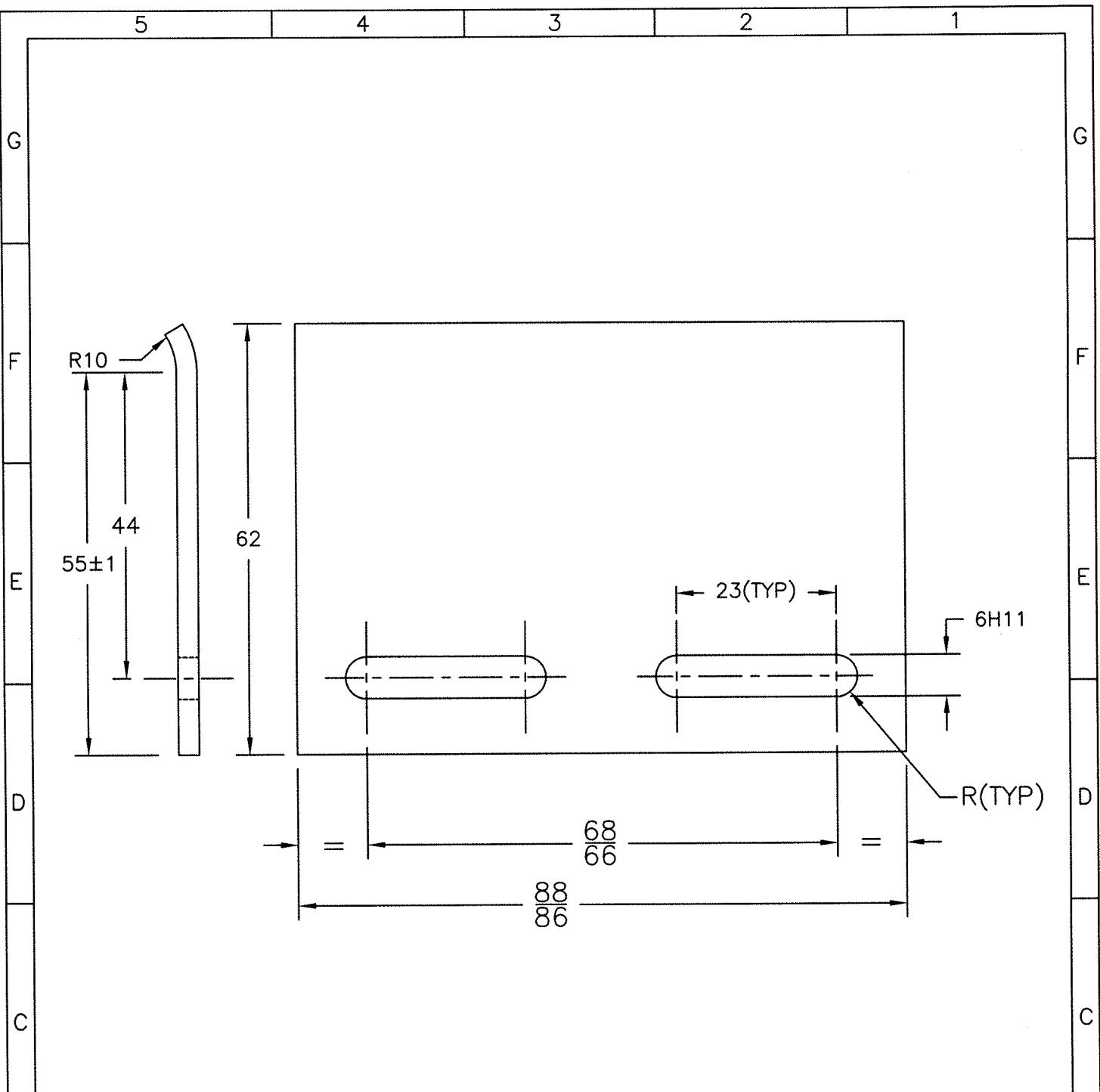

NOTE:---

1.REMOVE SHARP EDGES & CORNERS.

2.	---	DRAWING REDRAWN	14.01.15	<i>Raw</i>
SN0.	REGION	REVISION	DATE	SIGN
R E V I S I O N S				
		ARTIFICIAL LIMBS MANUFACTURING CORPORATION OF INDIA KANPUR		
DGN		NOM	BRACKET	
DRN	<i>Ashish</i>	MTL	SHEET MS HRA Gd'0'IS:1079 THK3.15mm(AA08)	
CHD	<i>Raw</i>	TOL	INTEGER ONLY ±0.500 mm ONE PLACE DECIMAL ±0.250 mm TWO PLACE DECIMAL ±0.126 mm	UNLESS SPECIFIED
DIM	IN mm	FIN	---	
SCALE	NTS			
APP	<i>Sa/DD 1</i>			
DATE	10.05.1983			
			DRG No: -TD 2 A 07 A 25	
			SHEET 10F1	

01	K	5	189
		5	4